

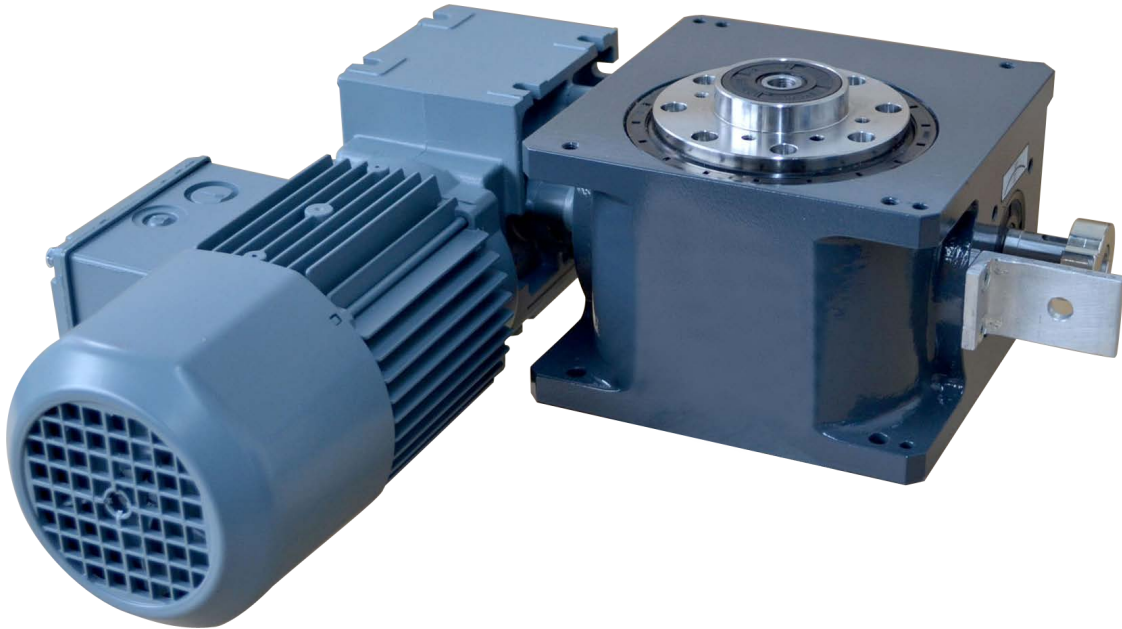

MOTION
INDEX DRIVES



RT TT Indexer

Operating Instructions



Contents

Contents	3
1 Overview / brief description	7
1.1 General description.....	7
2 About these Operating Instructions	9
2.1 Purpose of these Operating Instructions	9
2.1.1 Published by	10
3 Safety information	12
3.1 General information	12
3.2 Explanation of the symbols used	12
3.3 Intended use.....	12
3.4 Foreseeable misuse	13
3.4.1 Guarantee conditions	13
3.4.2 Directives, statutory provisions and standards.....	13
3.5 Technical condition of the machine.....	13
3.5.1 Make no changes in the safety provisions	13
3.6 General hazards	14
3.6.1 Risk of electric shock	14
3.6.2 Danger arising from mechanical components	14
3.7 Responsibility of the operator	15
3.7.1 Preventive measures	15
3.8 Staff qualification	16
3.8.1 Qualified staff	16
3.8.2 Competent specialists	16
3.8.3 Auxiliary staff	16
3.8.4 Servicing, repairing and maintaining the machine	16
3.9 Labeling.....	17
3.9.1 Rating plate	17
4 Construction and function	19
4.1 Construction Type RT and TT series S01	19
4.2 Construction Type RT and TT series S03	19
4.3 Construction Type RT400, RT 500, RT630, series S03	20
4.4 Function	20
4.5 Operating modes	21
4.5.1 Normal operation	21
4.5.2 Intermittent operation	21
4.5.3 Continuous operation	21
4.5.4 Reversing operation (reciprocating operation)	21
4.5.5 Inching mode	21
4.5.6 Emergency-Stop	21
4.6 Cycle time	22
4.7 Technical Data.....	23
4.7.1 Indexing accuracy for all Cylinder Cam Rotary Indexing Tables.....	23
4.7.2 Construction of the Cylinder Cam Rotary Indexing Table Type TT075 S03	23
4.7.3 Construction of the Cylinder Cam Rotary Indexing Table Type RT100 S03.....	24
4.7.4 Construction of the Cylinder Cam Rotary Indexing Table Type TT125 S03	25
4.7.5 Construction of the Cylinder Cam Rotary Indexing Table Type RT160 S03.....	26
4.7.6 Construction of the Cylinder Cam Rotary Indexing Table Type RT 200 S03.....	27
4.7.7 Construction of the Cylinder Cam Rotary Indexing Table Type RT250 S03.....	28
4.7.8 Construction of the Cylinder Cam Rotary Indexing Table Type TT250	29
4.7.9 Construction of the Cylinder Cam Rotary Indexing Table Type TT315 S03	30
4.7.10 Construction of the Cylinder Cam Rotary Indexing Table Type RT400 S03.....	31
4.7.11 Construction of the Cylinder Cam Rotary Indexing Table Type RT500 S03.....	32



4.7.12	Construction of the Cylinder Cam Rotary Indexing Table Type RT630 S03.....	33
5	Transport.....	35
5.1	Safety information.....	35
5.2	Transport inspection	35
5.2.1	Transport using sling equipment	36
5.3	Packaging, handling, unpacking	38
5.4	Installation location, place of use	38
6	Mechanical installation	40
6.1	Installation orientation.....	40
6.2	Installation and commissioning	41
6.2.1	Safety information.....	41
6.2.2	Installation.....	41
6.3	Adjustment of the position cam series S01	43
6.3.1	Minimizing time losses.....	43
7	Service and maintenance	45
7.1	Safety information in respect of maintenance	45
7.1.1	Qualified staff required	45
7.1.2	Maintenance tasks.....	45
7.1.3	Cleaning.....	45
7.2	Maintenance tasks.....	46
7.2.1	Maintenance plan	46
7.3	Checking the oil level.....	47
7.4	Lubrication	48
7.4.1	Requirements for lubricants.....	48
7.4.2	Lubricating the rotary indexing table Type RT400, RT500, RT630.....	48
7.5	Replacing cam follower.....	49
7.5.1	Replacing cam follower assembly sequence	49
8	Troubleshooting	52
8.1	Safety information.....	52
9	Disposal	54
9.1	Disassembly	54
9.2	Disposal.....	54
10	Replacement parts and consumables	56
10.1	Replacement parts and consumables Type RT	56
10.2	Replacement parts and consumables Type TT	57



1 Overview / brief description

1.1 General description

The Cylinder Cam Rotary Indexing Table Type RT or TT converts uniform input movement to an intermittent or uniformly, reduced and intermittent output movement. The intermittent, reduced and uniform output movement is generated by an induction-hardened, precision-finished cylinder cam.

The use of mathematical laws of motion guarantees a soft, shockproof and jerk-free movement that has been optimally designed for its intended purpose. The construction makes it possible to position the star wheel positively without any play.

No additional mechanical locking for the star wheel is necessary.

This can lead to mechanical over tightening and ultimately to the destruction of the rotary indexing table.

Power is provided either by means of a three-phase brake motor via worm drive or by means of a chain-wheel or belt wheel on the drive shaft of the rotary indexing table.

This is firmly connected to the cylinder cam, without any further internal gear sets, and it turns the star wheel through cam followers.

The type RT star wheel is mounted within a wire-race bearing assembly, stiff and free of play (inside steel rings – not in the casting). The type TT star wheel is mounted in tapered roller bearings, stiff and free of play. The shaft seals appropriate for each size seal off the rotary indexing table inside and out.

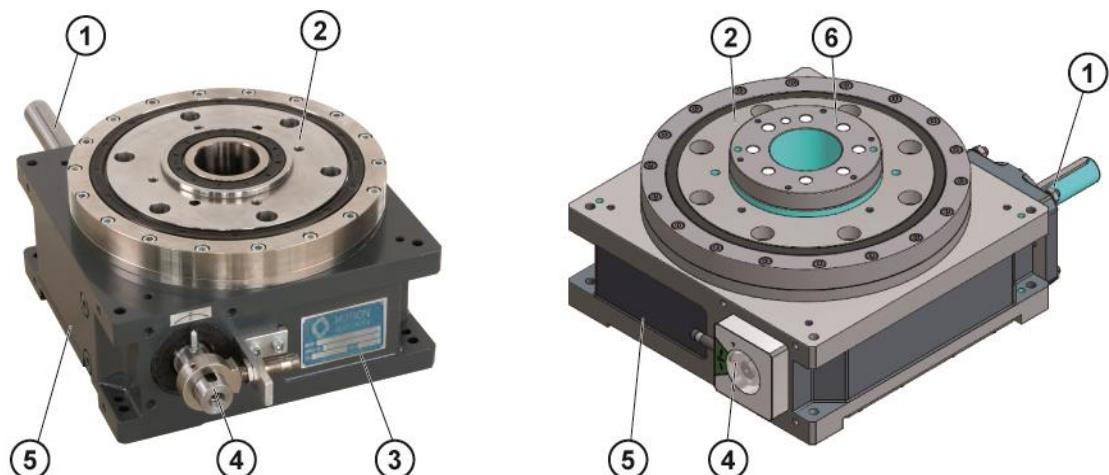

Figure: Construction of the Cylinder Cam Rotary Indexing Table, series S01 and S03

- (1) Input shaft (drive)
- (2) Star wheel (output)
- (3) Rating plate
- (4) Position indicator
- (5) Housing
- (6) Non-rotating center column only on series S03



2 About these Operating Instructions

Designation

These Operating Instructions describe the Cylinder Cam Rotary Indexing Table RT and TT. The Cylinder Cam Rotary Indexing Table RT and TT is referred to below as 'the machine'.

2.1 Purpose of these Operating Instructions

The Operating Instructions are intended to help you to:

- work efficiently
- ensure quality
- find information quickly
- avoid danger

Table of contents

The Operating Instructions have a table of contents at the front. This gives you an overview of all the sections in the document.

Headings and page numbers

The chapters are numbered sequentially. The sections within each chapter are numbered sequentially.

Safety information

Any safety information is placed before the descriptions of actions that may pose a risk. You will find a detailed description of the safety information in the chapter entitled Safety.

Text, symbols, figures

Instructions for performing various activities and other information are presented in small, discrete sections.

The information is presented using a combination of text, symbols and figures.

Instructions for performing action are described in the appropriate sequence and numbered accordingly.

Instructions for action

For the sake of clarity the instructions for action have been broken down into individual steps:

- ▶ Introductory text ...
- ⇒ Sub-items in lists

Lists

Any lists which do not include individual operating steps are indicated as follows:

- Lists...
 - Sub-items in lists

Figures

Figures, dimensions and technical data presented in these Operating Instructions may be subject to change.



Cross-references

Cross-references point you to additional descriptions within the Operating Instructions. (chapter number/page number)

Third-party components

Refer to the Operating Instructions of the relevant manufacturers for information on operation and maintenance of third-party components fitted in the system.

Additional documentation

To complement the information in these Operating Instructions, please read the following regulations and directives:

- safety regulations and accident prevention regulations
- instruction sheets, instruction booklets
- work instructions provided by the statutory accident insurance provider
- generally accepted occupational health regulations

Manufacturer

Motion Index Drives
1204 East Maple Rd
Troy MI 48083

Phone: 248-743-9999

Fax: 248-743-0749

E-Mail: info@mid.us.com

Internet: www.motionindexdrives.com

Technical information

The technical information, figures and data contained in these Operating Instructions are correct at the time of printing.

Our products undergo continuous further develop.

We therefore reserve the right to make any changes and improvements that we deem appropriate.

However, this does not, imply any obligation to apply such changes retrospectively to equipment already supplied.

2.1.1 Published by

Motion Index Drives
1204 East Maple Rd
Troy MI 48083

Reproduction of these Operating Instructions or extracts thereof in the form of a reprint or photocopy, on electronic storage media or by any other means is not permitted except with our written consent.

All rights reserved.



3 Safety information

3.1 General information

This document contains important information on the safe use of the machine. This information is intended to ensure personal safety and prevent damage to the machine. The information is intended for the operator and for properly trained, qualified and instructed staff responsible for operating and servicing the machine.

Additional task-specific safety information is included in the relevant sections on the different phases during the service life of the system.

3.2 Explanation of the symbols used

DANGER



DANGER!

This combination of symbol and alert word indicates an inherently dangerous situation which can be fatal or cause serious injury if it is not avoided.

WARNING



WARNING!

This combination of symbol and alert word indicates a potentially dangerous situation which can be fatal or cause serious injury if it is not avoided.

CAUTION



CAUTION!

This combination of symbol and alert word indicates a potentially dangerous situation which can cause minor injury.

NOTE



NOTE

This combination of symbol and alert word indicates a potentially dangerous situation which can cause damage to property or harm the environment if it is not avoided.

3.3 Intended use

The cylinder cam rotary indexing table is intended for installation in a surrounding construction, thus integrating it to form part of an overall system. The cylinder cam rotary indexing table is controlled by the overall system. The functions of the protective equipment are also connected to the cylinder cam rotary indexing table via the controller. The cylinder cam rotary indexing table may only be operated as part of a CE-compliant system.

Any use that deviates from the intended use is regarded as inappropriate use. This includes:

- any use outside the permitted operating limits
- any use in conjunction with foodstuffs
- any use in conjunction with aggressive materials (such as acids)
- transporting the system using the designated lifting points or eye bolts.
- The cylinder cam rotary indexing table of the given series is intended for use in potentially explosive environments according to EX II 2 G T4 (135°C), if they are equipped with the appropriate rating plate (see Section 3.9.1) and the appropriate declaration of conformity..
- Any add - on components must comply to the same appropriate declaration of conformity.



- Any add - on components must comply to the same appropriate declaration of conformity.
- To ensure conformity to ATEX the cylinder cam rotary indexing table may not be used for purposes other than those for which it has been selected and ordered.
- For use under different potentially explosive environments other than EX II 2 G T4 (135°C) please contact with Motion Index Drives.

The manufacturer shall not be liable for any damage resulting from such use. Intended use also includes observance of all the information in these instructions.

3.4 Foreseeable misuse

Any use beyond or other than the intended use is regarded as misuse.

3.4.1 Guarantee conditions

Changes to the structure of the materials used in the machine, e.g. the drilling of additional holes, can result in damage to the components. This is not regarded as intended use and may lead to loss of warranty or liability claims as a consequence.

3.4.2 Directives, statutory provisions and standards

The following statutory provisions and standards were applied:
Machine Directive 2006/42/EC, Annex I
Low Voltage Directive 2006/96/EC
EMC Directive 2004/108/EC
ATEX 95 Directive 94/9/EC

3.5 Technical condition of the machine

Do not use the machine if it is not in sound condition technically. If the machine is used when it is not in a sound condition technically, there is a risk of death or injury to staff and a risk of damage to property.

3.5.1 Make no changes in the safety provisions

The manufacturer has made safety provisions. No liability will be accepted if the operator of the machine makes any changes in the safety provisions without express permission.



3.6 General hazards

This section lists risks associated with the machine that remain even when it is operated according to its intended use.

In order to reduce the risk of personal injury or damage to property, and to avoid potentially dangerous situations, the safety information provided here and in the other sections of these Operating Instructions must be observed.

3.6.1 Risk of electric shock

DANGER



DANGER!

Risk of death by electrocution!

There is an immediate risk of fatal injury due to electric shock if live components are touched.

Damage to the insulation or to individual components can cause fatal injury.

- ▶ Only allow work on the electrical system to be carried out by qualified electrical engineers.
- ▶ In the event of damage to the insulation, immediately shut off the power supply and initiate a repair.
- ▶ Before starting work on active parts of the electrical system or equipment, ensure that it is completely powered down and cannot be switched on again.

3.6.2 Danger arising from mechanical components

WARNING



WARNING!

Risk of injury from moving parts!

Moving parts can cause serious injury.

- ▶ Do not reach into moving parts or carry out work on moving parts while the system is in operation.
- ▶ Never open any covers while the system is in operation.



3.7 Responsibility of the operator

The machine is to be used commercially according to its intended use. The operator of the machine is therefore subject to statutory occupational health and safety provisions.

In addition to the general safety information contained in this document, any further safety, accident prevention and environmental regulations applicable to the field of application of the machine must also be observed.

In particular, operators have the following obligations:

- They must always be fully informed of the most recent occupational safety regulations and perform a risk assessment to identify any additional hazardous locations and places resulting from the specific working conditions at the place of use. They must document any such findings in the form of operating instructions (work instructions, work descriptions, etc.) for use during operation.
- During the entire service life of the machine, they must check whether the operating instructions they have written are compliant with current regulations and make any necessary adjustments.
- They must unambiguously regulate and define who is responsible for carrying out installation, operation, maintenance and cleaning.
- They must ensure that the staff deployed have the necessary qualifications for the work they are instructed to perform.
- They must ensure that all staff who work on the machine have read and understood all the documents relevant for its operation (Operating Instructions, maintenance regulations, safety guidelines).
- They must provide training for the staff at regular intervals and inform them of potential dangers.
- They must bear the responsibility for personal injury and damage to property arising from manipulation of the machine. For this reason, the machine and its safety equipment must be inspected at regular intervals to ensure that they are in sound condition and functioning properly, and the results of this inspection must be suitably documented.
- They must ensure that the machine is always in a sound condition technically.

3.7.1 Preventive measures

It is recommended that the operator take the following preventive measures:

- Only allow qualified, trained and properly instructed staff to work on the machine.
- Unambiguously define the responsibilities of operating and service personnel.
- Supplement these Operating Instructions with
 - stipulations deriving from national and regional labor and environmental regulations
 - adjust information covering specific operational aspects (workflows, supervisory obligations, reporting obligations, fire alarm equipment, etc.)
- Occasionally check to confirm that the Operating Instructions are being used and that such use is correct, and when necessary repeat the instruction process.
- Ensure that all documentation is permanently available in a readable form and easily accessible at the point of use.
- Observe any periodic checks and inspections that are required (by law) or specified in this document.
- Replace in good time any components indicated in these documents as being crucial for safety.
- Regularly inspect the machine to ensure that the safety equipment operates correctly.
- Make sure that safety information and hazard warnings on the machine and in the working area are always legible.
- Take steps to ensure that the machine is regularly inspected for visible damage and defects.



3.8 Staff qualification

The various activities described in these Operating Instructions require different qualifications of the staff entrusted with these duties.

WARNING



Danger if staff are insufficiently qualified!

Persons who are inadequately qualified are unable to assess the risks associated with working on the machine and expose themselves and others to the risk of serious or fatal injury.

- ▶ Ensure that all work is performed only by suitably qualified persons.
- ▶ Keep insufficiently qualified persons at a safe distance from the working area.

3.8.1 Qualified staff

For the purposes of these Operating Instructions, qualified staff are understood to be

- operators who have been specially trained and instructed in working with the machine,
- installation and service staff who have appropriate expertise in setting up and maintaining the machine and who are familiar with the safety information,
- The qualified staff must have read and understood the contents of the Operating Instructions before the machine is taken into service and must have been informed of the risks associated with working with the machine by the machine operator.
- A knowledge of first aid is required.

3.8.2 Competent specialists

Competent specialists are persons whose specialist training and experience have given them sufficient knowledge with respect to using this machine and who are sufficiently familiar with the relevant statutory occupational health regulations, accident prevention regulations, directives, and generally approved technical practice that they are able to assess whether the condition of the machine allows it to be used safely.

3.8.3 Auxiliary staff

Work on or in the vicinity of this machine which is not associated with the actual operation of the machine (e.g. cleaning, transport, material provisioning, etc.) can be performed by other persons. Before the machine is taken into service, the qualified staff of the machine operator must instruct such persons with regard to the nature of the work to be performed and the risks associated with working on the machine. Take special care when instructing persons who cannot read or write, and instruct them separately!

3.8.4 Servicing, repairing and maintaining the machine

Service, repair and maintenance work on the machine may only be carried out by service engineers of the manufacturer or by qualified staff authorized by Motion Index Drives. When carrying out such work, always cordon off the working area carefully!



3.9 Labeling

3.9.1 Rating plate

There is a rating plate attached to the machine:

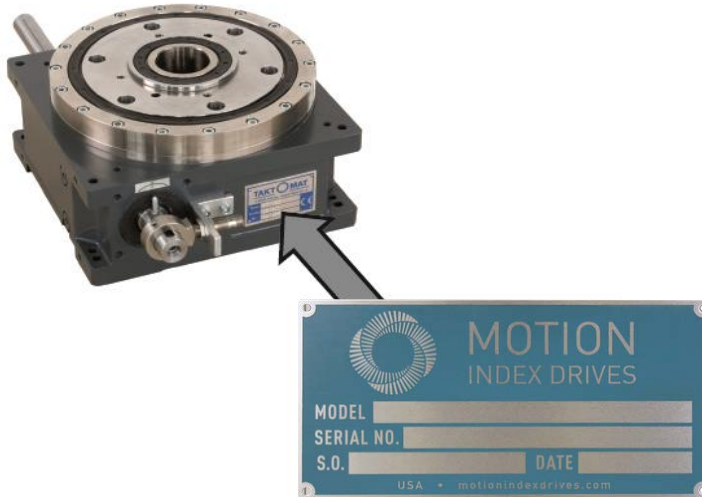

Figure: Position of a rating plate



Figure: Example of a rating plate

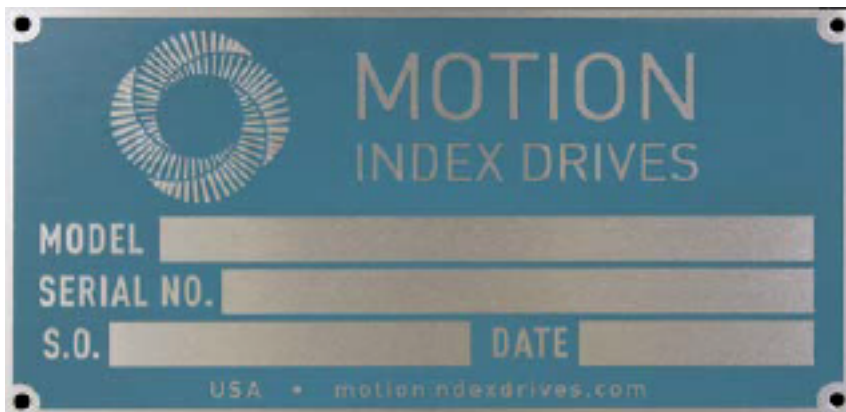

Figure: Example of a rating plate ATEX 95



4 Construction and function

4.1 Construction Type RT and TT series S01

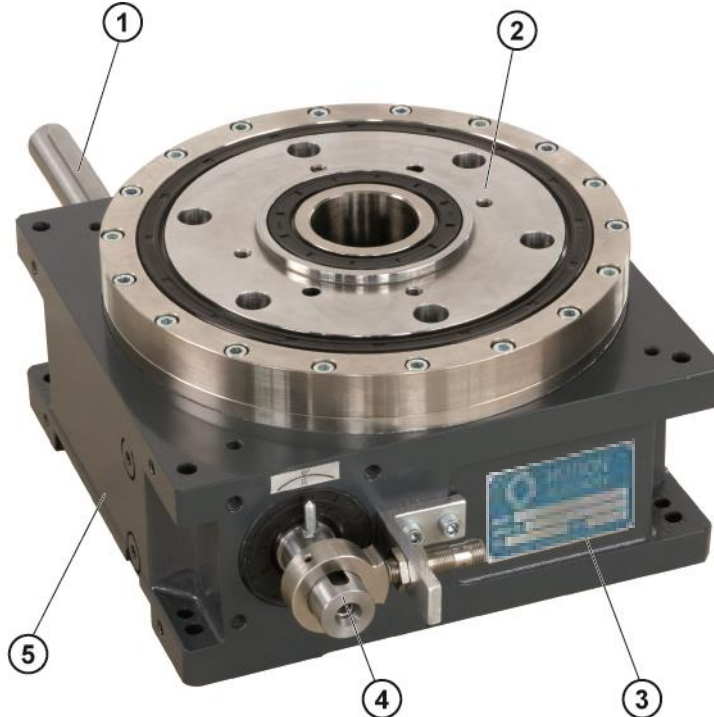

Figure: Construction of the Cylinder Cam Rotary Indexing Table RT and TT series S01

4.2 Construction Type RT and TT series S03

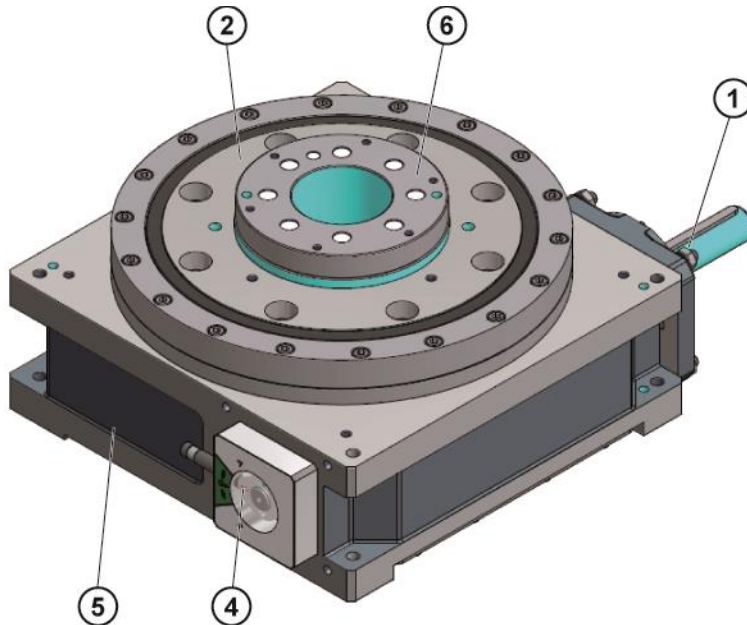
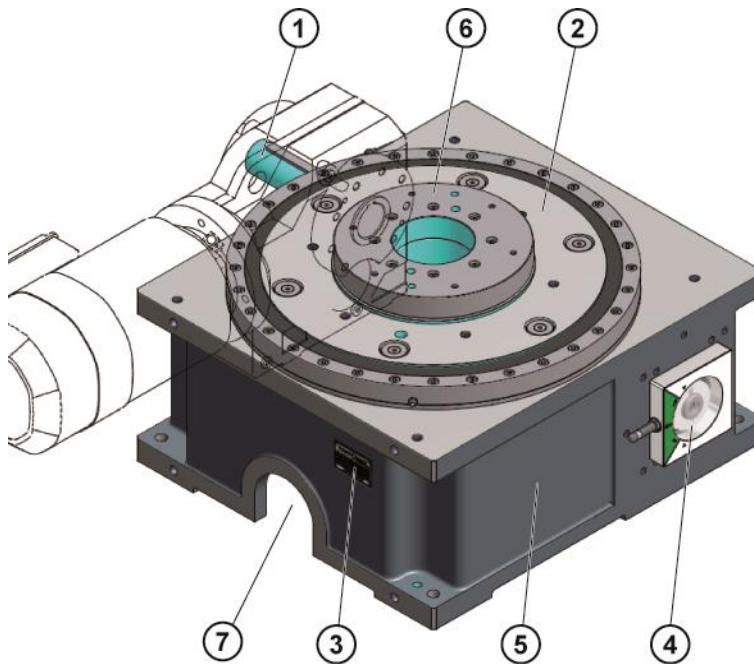

Figure: Construction of the Cylinder Cam Rotary Indexing Table RT and TT series S03

- (1) Input shaft (drive)
- (2) Star wheel (output)
- (3) Rating plate
- (4) Position indicator
- (5) Housing
- (6) Non rotating center column



4.3 Construction Type RT400, RT 500, RT630, series S03



- (1) Input shaft (drive)
- (2) Star wheel (output)
- (3) Rating plate
- (4) Position indicator
- (5) Housing
- (6) Non rotating center column
- (7) Cable aperture

4.4 Function

The drive unit drives the star wheel (2) via the input shaft (1) and the cylinder cam. The output plane is perpendicular to the drive plane. The machine converts a uniform radial movement on the drive side to an intermittent or uniformly reduced output movement. The accessories are mounted on the star wheel (2). The position indicator (4) shows the current position of the cylinder cam. The rating plate (3) is attached to the housing. If required additional accessories are mounted on the non rotating center column (6) (only possible on series S03). The housing (5) of the cylinder cam rotary indexing table from type RT400 on has a cable aperture (7).



4.5 Operating modes

The Cylinder Cam Rotary Indexing Table Type RT and TT has the following operating modes:

- Normal operation
 - Intermittent operation
 - Continuous operation
 - Reversing operation (Oscilating operation)
- Inching mode
- Emergency-Stop

NOTE



Do not operate in inching mode without an appropriate rotary table controller.

4.5.1 Normal operation

Normal operation is regarded as the movement of the drive flange in a direction from one dwell position to the next. The rotational direction of the drive flange is determined by the rotational direction of the drive. With a three-phase motor this can easily be reversed by swapping two phases of the supply voltage.

4.5.2 Intermittent operation

The drive shaft stops in the dwell phase. The step time is fixed. The dwell period is variable. This mode of operation is used in plants with much longer processing times than times and is the most common mode of operation.

4.5.3 Continuous operation

The rotary table runs continuously without the motor stopping. Step and dwell times are fixed and are run through continuously. The drive motor has only one rotational direction. This mode of operation is frequently used in fast-running plants with short processing times. The rotary indexing table is mechanically synchronized to the rest of the plant by the free drive shaft. The ratio of dwell to step time can be adjusted within certain limits by Motion Index Drives when producing the cam.

4.5.4 Reversing operation (reciprocating operation)

The drive of the rotary indexing table is always reversed in the dwell phase. In this mode of operation, the drive flange shuttles back and forth between two positions. With rotation angles of less than 90° on the drive flange, the cam can be constructed in such a way that continuous reversing operation is possible without the direction of the drive being reversed.

4.5.5 Inching mode

In inching operation, the drive flange moves in small increments between two dwell positions. The cylinder cam cannot gently accelerate and decelerate the accumulated load. This puts the hardware under stress, since any acceleration that occurs during the inching operation exceeds that of normal operation many times over. No inching operation is permitted if there are no suitable rotary indexing table controls that allow gentle acceleration and braking of the load outside the dwell phase.

4.5.6 Emergency-Stop

Emergency stop is comparable with the stopping in inching operation. Here, too, the stopping and re-starting of the accumulated load occurs outside the dwell phase. Frequent emergency-stop situations should be avoided or should take place by using the rotary indexing table control TIC in such a way that there is no danger to the mechanism.



4.6 Cycle time

A complete cycle of the rotary indexing table is defined as the indexing of the drive flange from one dwell position to the next. The cycle time consists of the step time and dwell time together. The step time corresponds to the step angle of the cam and the dwell time corresponds to the angle without the cam gradient.



Figure: Detail 0° cam gradient

(1) 0° cam gradient = Dwell phase

Example: RT 160-8-270

This is a rotary indexing table size 160 with 8 index points (8x45° drive flange rotation), a switch angle of the cam of 270° and a dwell angle of 90°. With an input rotational speed of 60 rpm and continuous input rotational speed, the rotary indexing table will execute 60 cycles per minute. The step time of the drive flange is 0.75s. The dwell time is 0.25s.



4.7 Technical Data

4.7.1 Indexing accuracy for all Cylinder Cam Rotary Indexing Tables

From internal transmission ratio 16 on the pitch error on the cylinder cam rises by 5" to 8" due to multi point locking.

4.7.2 Construction of the Cylinder Cam Rotary Indexing Table Type TT075 S03

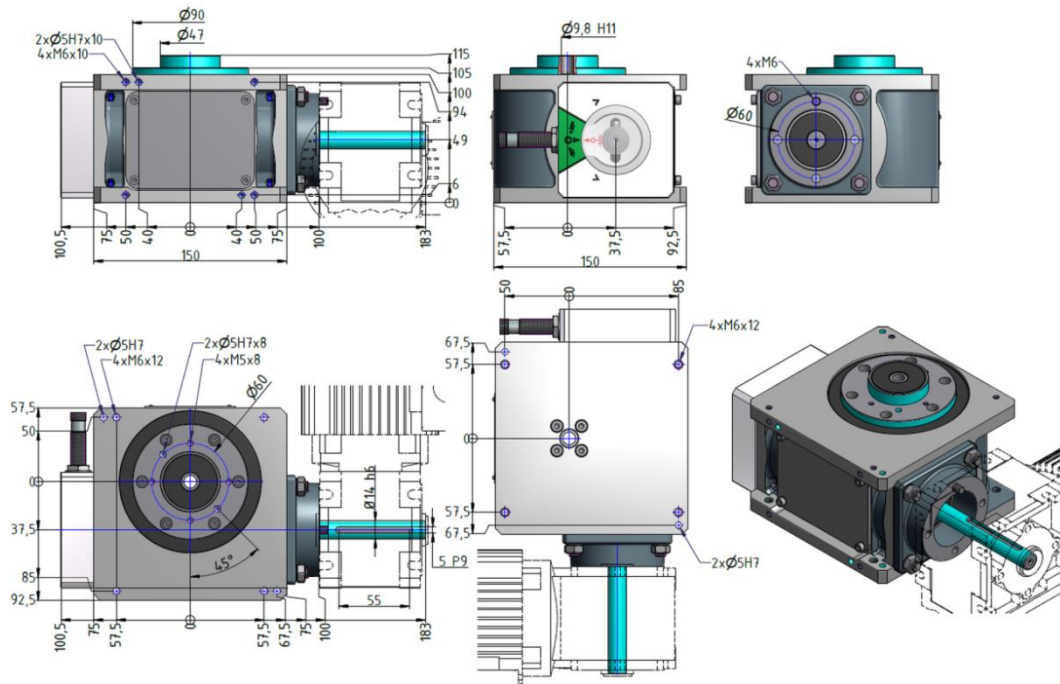

Primary dimensions

Star wheel Ø [mm]	90
Height (mounting surface of star wheel) [mm]	105
Internal Ø [mm]	9.8
Maximum recommended accessory plate Ø [mm]	500
Approx. weight of rotary indexing table without drive [kg]	12
Standard internal transmission ratio	2,3,4,6,8,10,12,16,20,24,30,36
Direction	cw, ccw, reversing
Installation orientation	horizontal, vertical, upside down

Precision

Indexing accuracy in angular seconds ± ["]	28
Axial runout on Star wheel -Ø ± [mm]	0.01
Concentric runout on Star wheel -Ø ± [mm]	0.01

Max. strain on Star wheel

Axial force Fa [kN]	1.5
Radial force Fr[kN]	0.6
Tilting moment Mk [kNm]	0.5

Max. strain on central column

Axial force Fa [kN]	0.5
Tilting moment Mk [kNm]	0.04



4.7.3 Construction of the Cylinder Cam Rotary Indexing Table Type RT100 S03

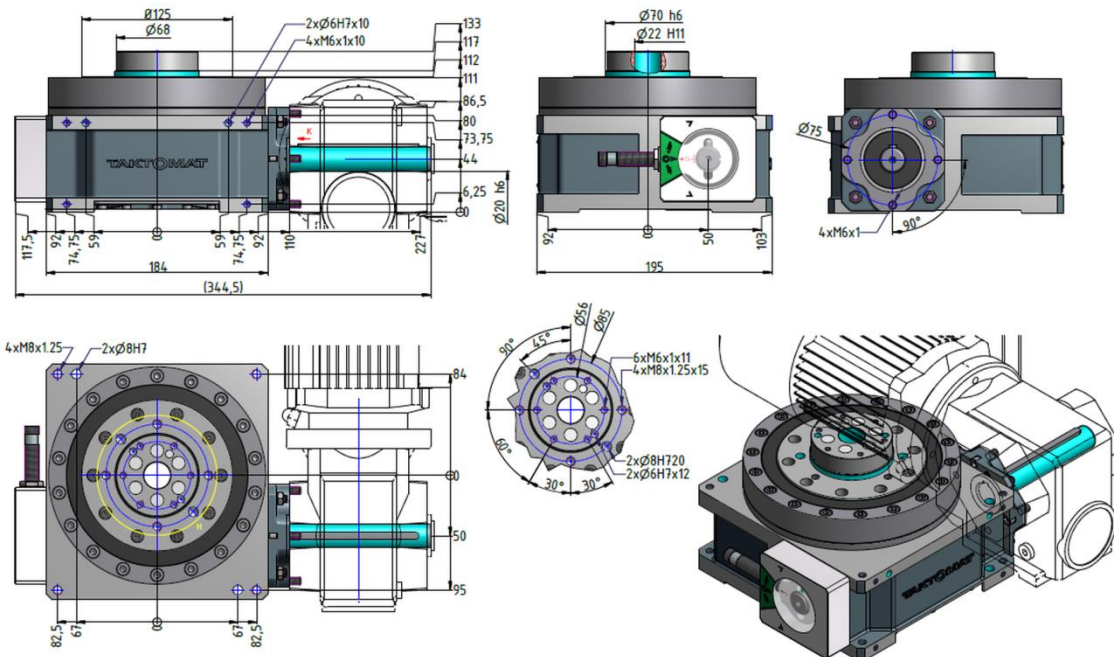

Primary dimensions

Star wheel Ø [mm]	125
Height (mounting surface of star wheel) [mm]	112
Internal Ø [mm]	22
Maximum recommended accessory plate Ø [mm]	800
Approx. weight of rotary indexing table without drive [kg]	32
Standard internal transmission ratio	2,3,4,6,8,10,12,16,20,24,30,36
Direction	cw, ccw, reversing
Installation orientation	horizontal, vertical, upside down

Precision

Indexing accuracy in angular seconds ± ["]	35
Axial runout on Star wheel -Ø ± [mm]	0.01
Concentric runout on Star wheel -Ø ± [mm]	0.01

Max. strain on Star wheel

Axial force Fa [kN]	6
Radial force Fr[kN]	3.8
Tilting moment Mk [kNm]	0.7

Max. strain on central column

Axial force Fa [kN]	5
Tilting moment Mk [kNm]	0.19



4.7.4 Construction of the Cylinder Cam Rotary Indexing Table Type TT125 S03

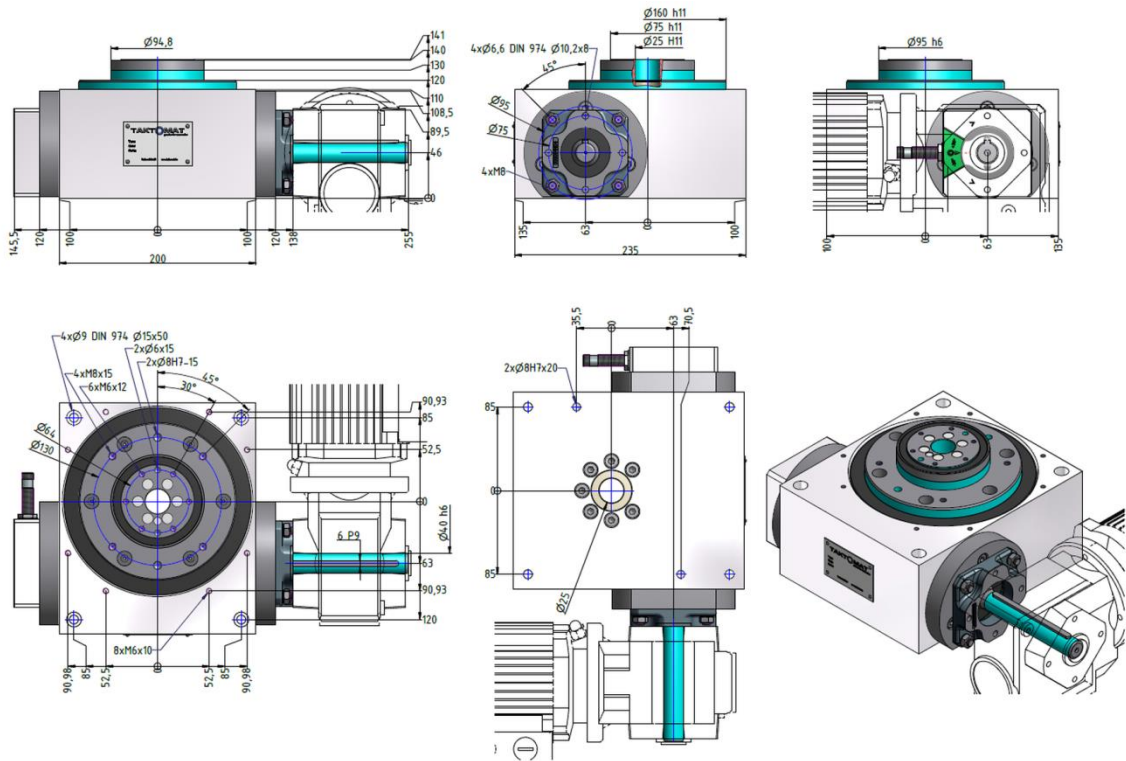

Primary dimensions

Star wheel Ø [mm]	160
Height (mounting surface of star wheel) [mm]	120
Internal Ø [mm]	35
Maximum recommended accessory plate Ø [mm]	1000
Approx. weight of rotary indexing table without drive [kg]	24
Standard internal transmission ratio	2,3,4,6,8,10,12,16,20,24,30,36
Direction	cw, ccw, reversing
Installation orientation	horizontal, vertical, upside down

Precision

Indexing accuracy in angular seconds ± ["]	30
Axial runout on Star wheel -Ø ± [mm]	0.015
Concentric runout on Star wheel -Ø ± [mm]	0.015

Max. strain on Star wheel

Axial force Fa [kN]	6
Radial force Fr[kN]	2.8
Tilting moment Mk [kNm]	0.2

Max. strain on central column

Axial force Fa [kN]	3
Tilting moment Mk [kNm]	0.2



4.7.5 Construction of the Cylinder Cam Rotary Indexing Table Type RT160 S03

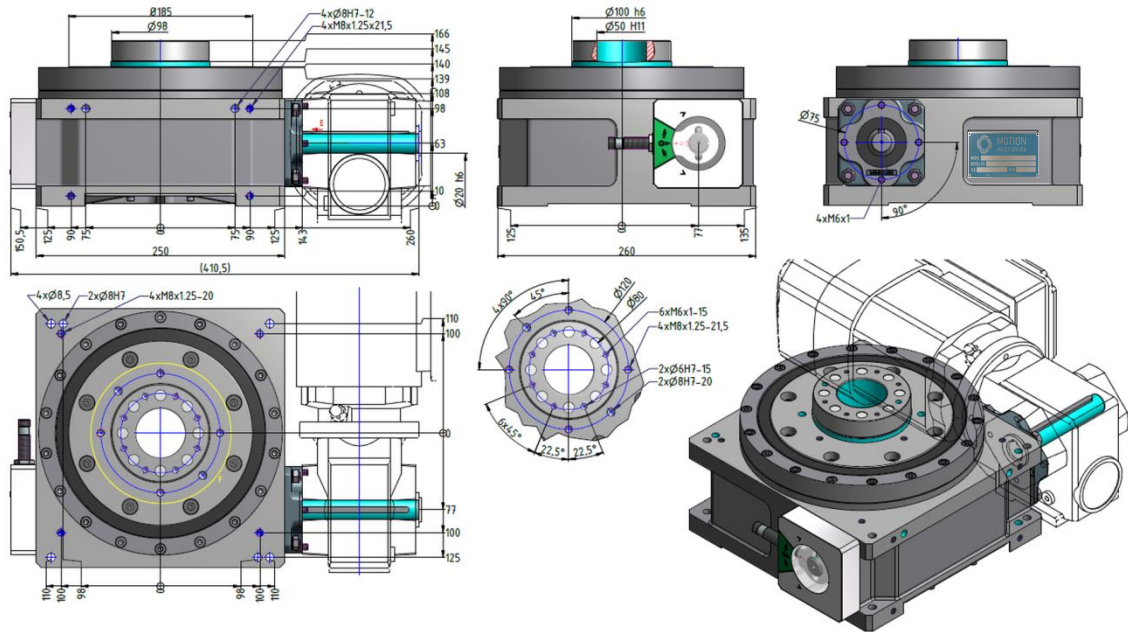

Primary dimensions

Star wheel Ø [mm]	185
Height (mounting surface of star wheel) [mm]	140
Internal Ø [mm]	50
Maximum recommended accessory plate Ø [mm]	1300
Approx. weight of rotary indexing table without drive [kg]	31
Standard internal transmission ratio	2,3,4,6,8,10,12,16,20,24,30,36
Direction	cw, ccw, reversing
Installation orientation	horizontal, vertical, upside down

Precision

Indexing accuracy in angular seconds ± ["]	30
Axial runout on Star wheel -Ø ± [mm]	0.01
Concentric runout on Star wheel -Ø ± [mm]	0.01

Max. strain on Star wheel

Axial force Fa [kN]	15
Radial force Fr[kN]	8
Tilting moment Mk [kNm]	2.7

Max. strain on central column

Axial force Fa [kN]	7.5
Tilting moment Mk [kNm]	0.53



4.7.6 Construction of the Cylinder Cam Rotary Indexing Table Type RT 200 S03

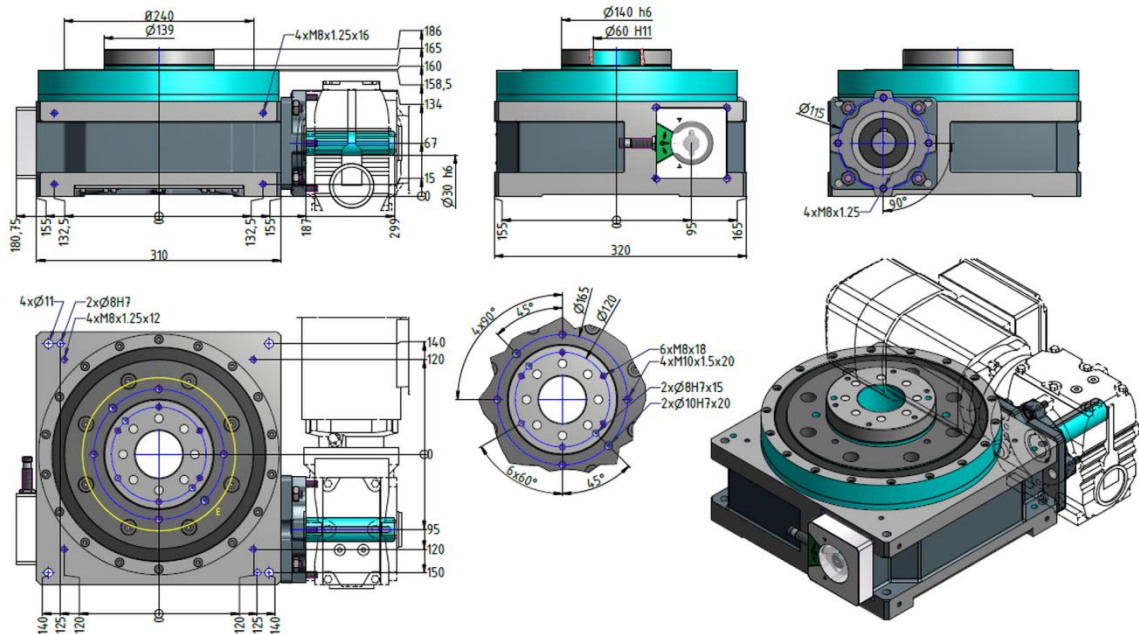

Primary dimensions

Star wheel Ø [mm]	240
Height (mounting surface of star wheel) [mm]	160
Internal Ø [mm]	60
Maximum recommended accessory plate Ø [mm]	1800
Approx. weight of rotary indexing table without drive [kg]	63
Standard internal transmission ratio	2,3,4,6,8,10,12,16,20,24,30,36
Direction	cw, ccw, reversing
Installation orientation	horizontal, vertical, upside down

Precision

Indexing accuracy in angular seconds ± ["]	30
Axial runout on Star wheel -Ø ± [mm]	0.01
Concentric runout on Star wheel -Ø ± [mm]	0.01

Max. strain on Star wheel

Axial force Fa [kN]	21
Radial force Fr[kN]	11
Tilting moment Mk [kNm]	3.7

Max. strain on central column

Axial force Fa [kN]	12.5
Tilting moment Mk [kNm]	1.2

4.7.7 Construction of the Cylinder Cam Rotary Indexing Table Type RT250 S03

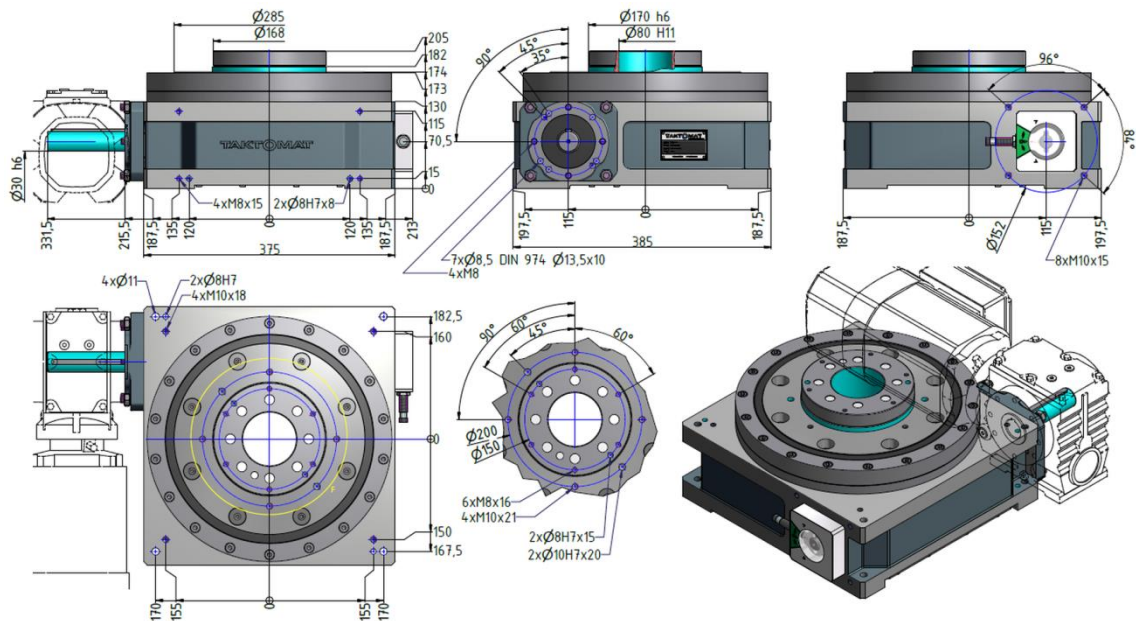

Primary dimensions

Star wheel Ø [mm]	285
Height (mounting surface of star wheel) [mm]	174
Internal Ø [mm]	80
Maximum recommended accessory plate Ø [mm]	2200
Approx. weight of rotary indexing table without drive [kg]	100
Standard internal transmission ratio	2,3,4,6,8,10,12,16,20,24,30,36
Direction	cw, ccw, reversing
Installation orientation	horizontal, vertical, upside down

Precision

Indexing accuracy in angular seconds ± ["]	25
Axial runout on Star wheel -Ø ± [mm]	0.01
Concentric runout on Star wheel -Ø ± [mm]	0.01

Max. strain on Star wheel

Axial force Fa [kN]	27
Radial force Fr[kN]	14
Tilting moment Mk [kNm]	5

Max. strain on central column

Axial force Fa [kN]	25
Tilting moment Mk [kNm]	2



4.7.8 Construction of the Cylinder Cam Rotary Indexing Table Type TT250

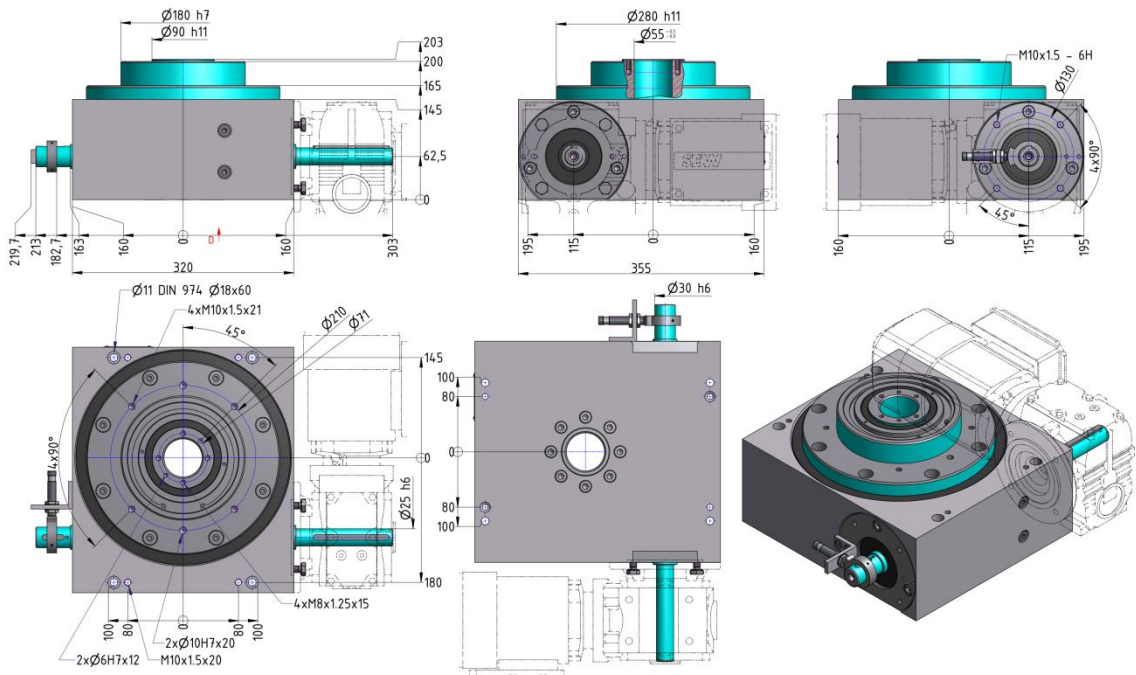

Primary dimensions

Star wheel Ø [mm]	280
Height (mounting surface of star wheel) [mm]	165
Internal Ø [mm]	50
Maximum recommended accessory plate Ø [mm]	2000
Approx. weight of rotary indexing table without drive [kg]	77
Standard internal transmission ratio	2,3,4,6,8,10,12,16,20,24,30,36
Direction	cw, ccw, reversing
Installation orientation	horizontal, vertical, upside down

Precision

Indexing accuracy in angular seconds ± ["]	25
Axial runout on Star wheel -Ø ± [mm]	0.015
Concentric runout on Star wheel -Ø ± [mm]	0.015

Max. strain on Star wheel

Axial force Fa [kN]	23
Radial force Fr[kN]	24
Tilting moment Mk [kNm]	2

Max. strain on central column

Axial force Fa [kN]	12
Tilting moment Mk [kNm]	2



4.7.9 Construction of the Cylinder Cam Rotary Indexing Table Type TT315 S03

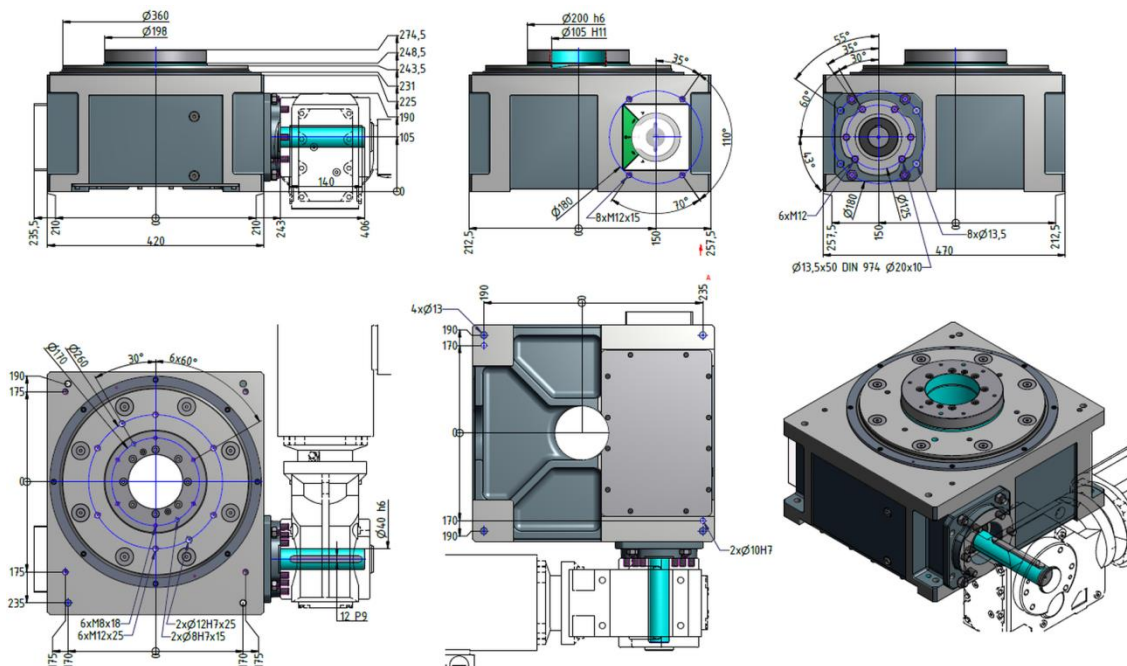

Primary dimensions

Star wheel Ø [mm]	360
Height (mounting surface of star wheel) [mm]	243,5
Internal Ø [mm]	90
Maximum recommended accessory plate Ø [mm]	2800
Approx. weight of rotary indexing table without drive [kg]	193
Standard internal transmission ratio	2,3,4,6,8,10,12,16,20,24,30,36
Direction	cw, ccw, reversing
Installation orientation	horizontal, vertical, upside down

Precision

Indexing accuracy in angular seconds ± ["]	23
Axial runout on Star wheel -Ø ± [mm]	0.01
Concentric runout on Star wheel -Ø ± [mm]	0.01

Max. strain on Star wheel

Axial force Fa [kN]	32
Radial force Fr[kN]	17
Tilting moment Mk [kNm]	5

Max. strain on central column

Axial force Fa [kN]	28
Tilting moment Mk [kNm]	4



4.7.10 Construction of the Cylinder Cam Rotary Indexing Table Type RT400 S03

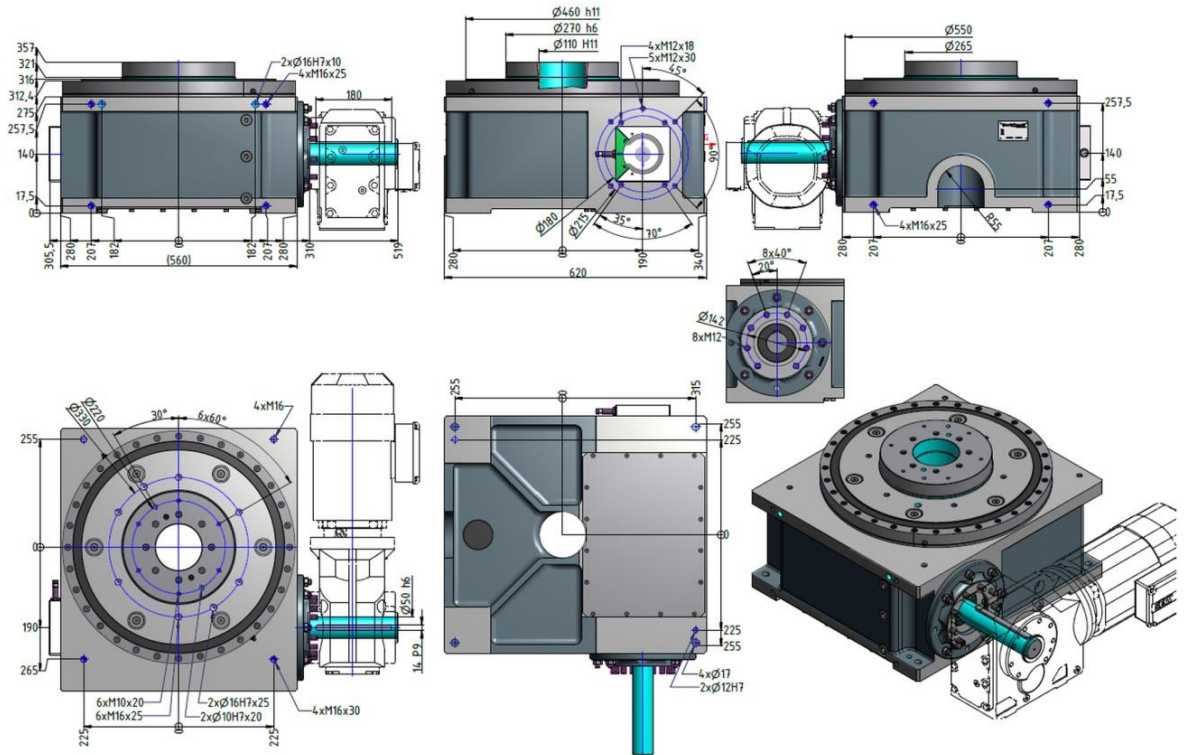

Primary dimensions

Star wheel Ø [mm]	460
Height (mounting surface of star wheel) [mm]	316
Internal Ø [mm]	110
Maximum recommended accessory plate Ø [mm]	3500
Approx. weight of rotary indexing table without drive [kg]	325
Standard internal transmission ratio	2,3,4,6,8,10,12,16,20,24,30,36
Direction	cw, ccw, reversing
Installation orientation	horizontal, vertical, upside down

Precision

Indexing accuracy in angular seconds ± ["]	18
Axial runout on Star wheel -Ø ± [mm]	0.01
Concentric runout on Star wheel -Ø ± [mm]	0.01

Max. strain on Star wheel

Axial force Fa [kN]	50
Radial force Fr[kN]	26
Tilting moment Mk [kNm]	10

Max. strain on central column

Axial force Fa [kN]	45
Tilting moment Mk [kNm]	5.5



4.7.11 Construction of the Cylinder Cam Rotary Indexing Table Type RT500 S03

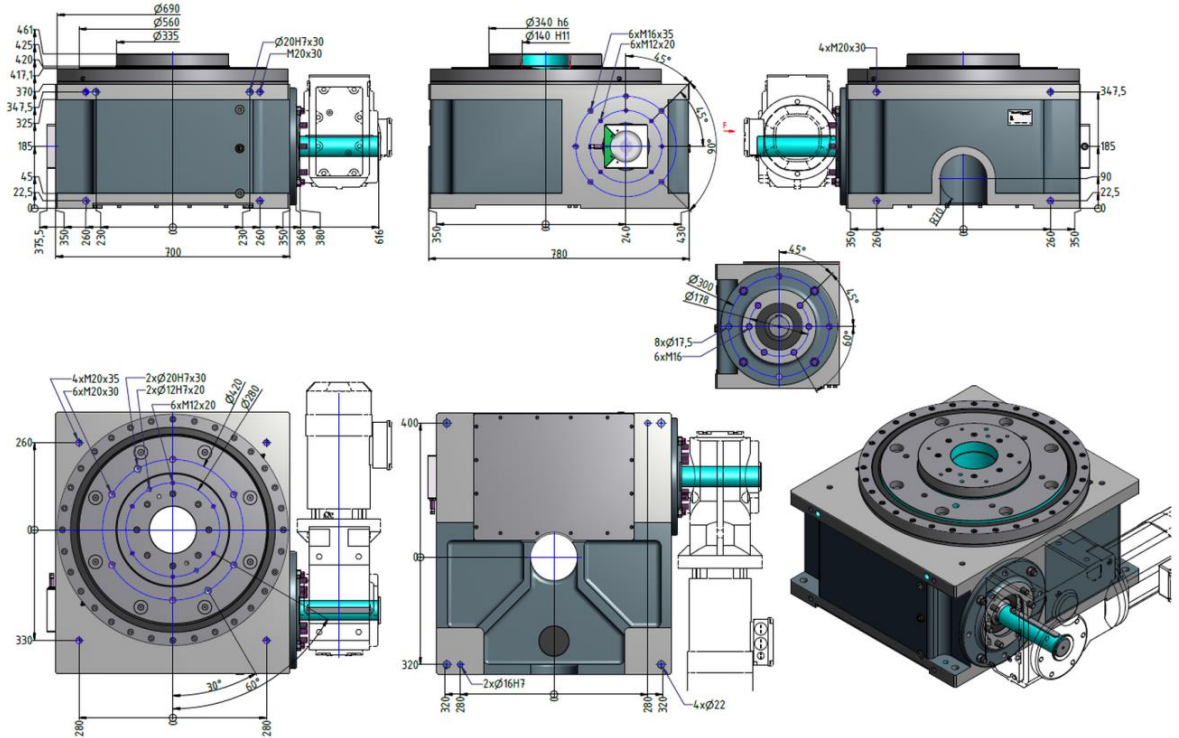

Primary dimensions

Star wheel Ø [mm]	560
Height (mounting surface of star wheel) [mm]	420
Internal Ø [mm]	140
Maximum recommended accessory plate Ø [mm]	4500
Approx. weight of rotary indexing table without drive [kg]	600
Standard internal transmission ratio	2,3,4,6,8,10,12,16,20,24,30,36
Direction	cw, ccw, reversing
Installation orientation	horizontal, vertical, upside down

Precision

Indexing accuracy in angular seconds ± ["]	15
Axial runout on Star wheel -Ø ± [mm]	0.01
Concentric runout on Star wheel -Ø ± [mm]	0.01

Max. strain on Star wheel

Axial force Fa [kN]	84
Radial force Fr[kN]	49
Tilting moment Mk [kNm]	22

Max. strain on central column

Axial force Fa [kN]	60
Tilting moment Mk [kNm]	7.8



4.7.12 Construction of the Cylinder Cam Rotary Indexing Table Type RT630 S03

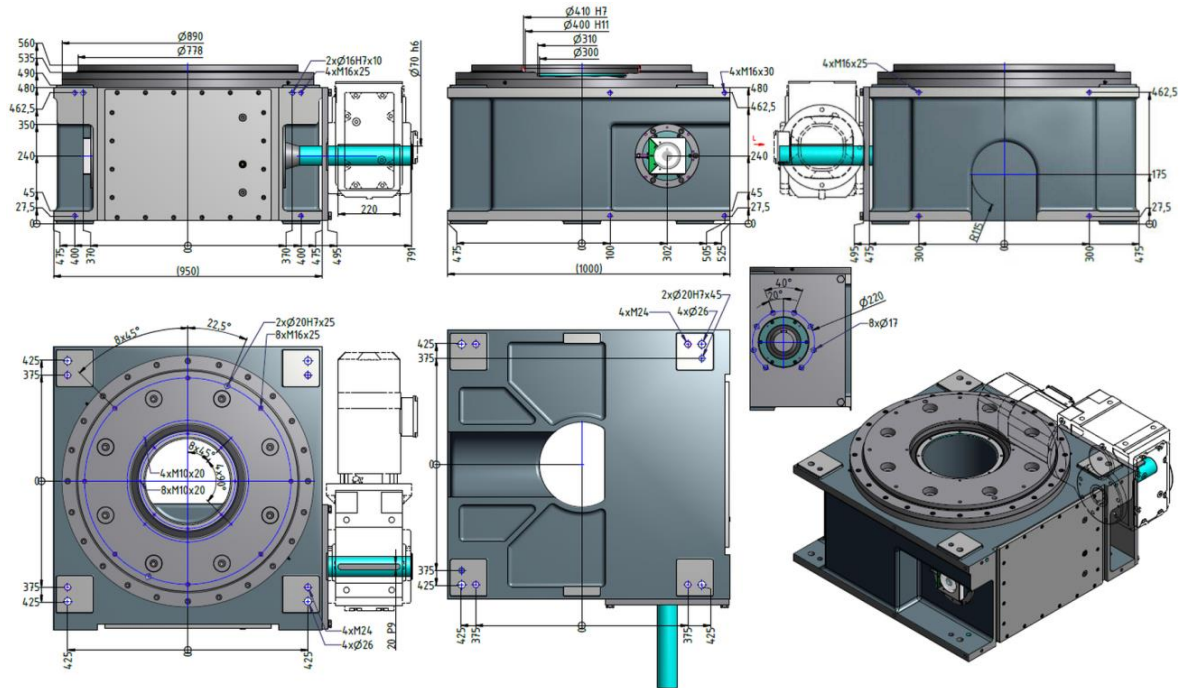

Primary dimensions

Star wheel Ø [mm]	778
Height (mounting surface of star wheel) [mm]	560
Internal Ø [mm]	250
Maximum recommended accessory plate Ø [mm]	6000
Approx. weight of rotary indexing table without drive [kg]	1600
Standard internal transmission ratio	2,3,4,6,8,10,12,16,20,24,30,36
Direction	cw, ccw, reversing
Installation orientation	horizontal, vertical, upside down

Precision

Indexing accuracy in angular seconds ± ["]	15
Axial runout on Star wheel -Ø ± [mm]	0.01
Concentric runout on Star wheel -Ø ± [mm]	0.01

Max. strain on Star wheel

Axial force Fa [kN]	145
Radial force Fr[kN]	86
Tilting moment Mk [kNm]	41

Max. strain on central column

Axial force Fa [kN]	80
Tilting moment Mk [kNm]	9



5 Transport

5.1 Safety information

NOTE



Damage arising from improper transport!

Improper transport can cause significant damage to property.

- Take care and take note of the symbols on the packaging when unloading the machine on delivery and when transporting it on the premises.

5.2 Transport inspection

Immediately on receipt, check to make certain that the delivery is complete and has not been damaged during transport:

Proceed as follows if there are visible signs of damage during transport:

- ▶ Do not accept the delivery or only do so conditionally.
- ▶ Record the extent of the damage on the transport documentation or on the associated delivery note.
- ▶ Immediately report any damage to the manufacturer of the machine.

DANGER



Risk of fatal injury from suspended loads and falling parts!

Parts can fall during transport and cause serious or fatal injury.

- ▶ Do not walk under suspended loads.
- ▶ Keep people clear of the danger zone.
- ▶ Always use lifting gear with a sufficient load capacity.
- ▶ Always use forklift trucks or pallet trucks with a sufficient load capacity and fork length.
- ▶ Do not leave the load suspended if you leave the working area.



5.2.1 Transport using sling equipment

Staff: Qualified staff

Protective equipment: Protective gloves, protective footwear and hard hat

Transport the machine as follows if you are using sling equipment:

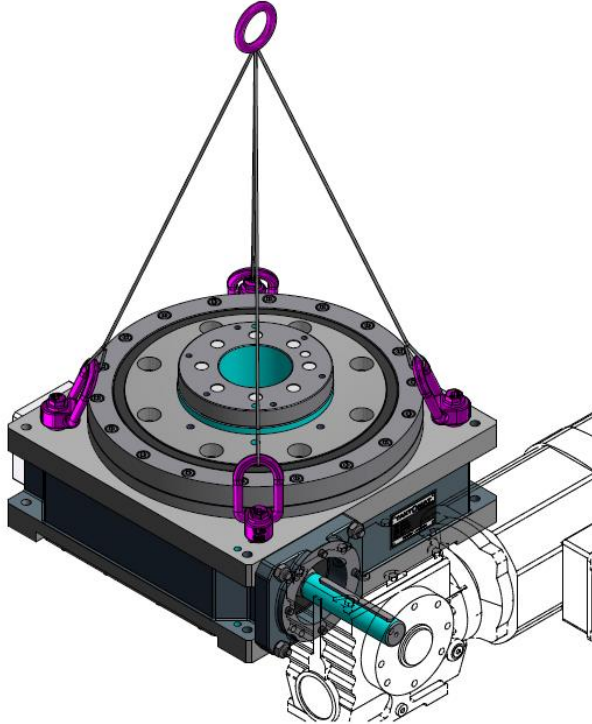

Figure: Transport using sling equipment

- ▶ The sling equipment (see figure) must be attached in the threaded holes (see table and dimensions sheet) in the positions shown in the figure and checked to ensure that it is working correctly (see the instructions for the sling equipment).

Thread table for screw attachment points:

Suitable threaded holes are provided on cylinder cam rotary indexing tables to accommodate sling equipment. Please refer to the dimensions sheet in the technical data for the thread sizes.

Recommendation Sling equipment:

Type	Number of sling points	Recommendation Sling equipment:	Thread
RT100	4	VLBG	M8
RT160	4	VLBG	M8
RT200	4	VLBG	M8
RT250	4	VLBG	M10
RT400	4	VLBG	M16
RT630	4	VLBG	M24
TT75	4	VRS-F	M6
TT125	4	VRS-F	M6
TT250 / TT252	4	VRS-F	M10
TT315	4	VRS-F	M12



Lifting instructions

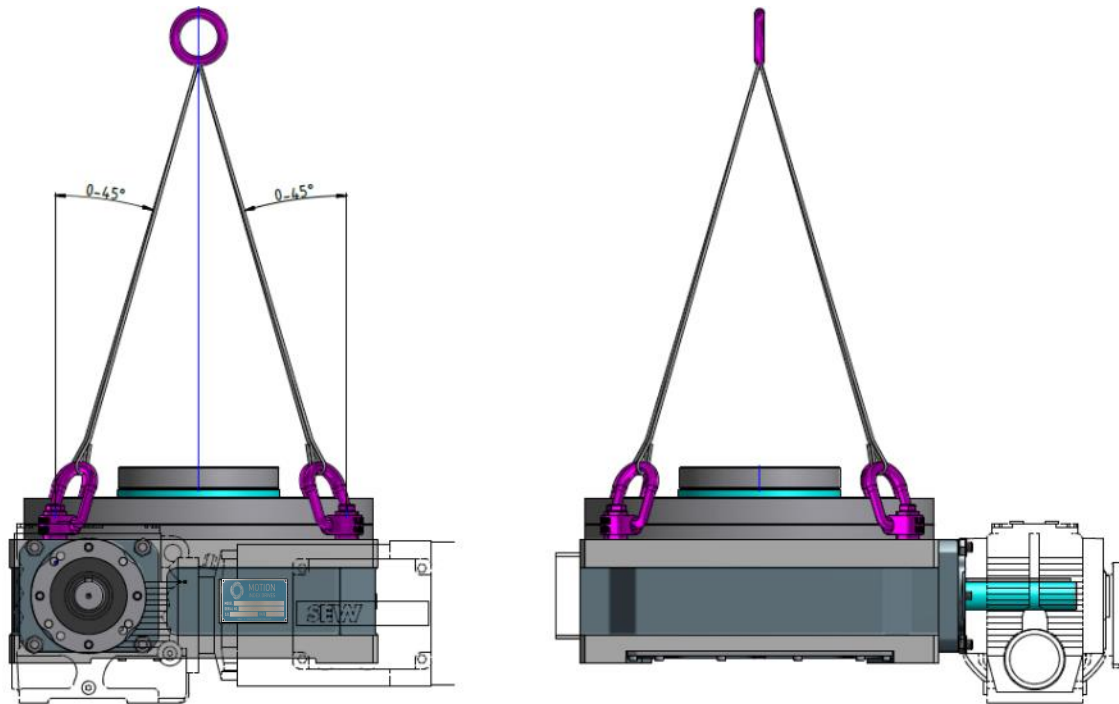

Figure: Lifting instructions

The angle between the perpendicular and the sling chain must lie between 0° and 45° .



5.3 Packaging, handling, unpacking

The Cylinder Cam Rotary Indexing Table Type RT and TT is packed in plastic sheeting and secured to a pallet for transportation.

NOTE



The machine must not be allowed to become wet while it is being transported.

- ▶ Remove the packaging carefully and dispose of it with due regard to environmental considerations.

5.4 Installation location, place of use

The machine should be stored and set up under the following conditions:

- Do not store the system in the open.
- Store the machine in a dry room at a temperature above 8°C.
- Do not expose the system to any aggressive agents.
- Protect from direct sunlight.



6 Mechanical installation

6.1 Installation orientation

Possible Installation orientations.

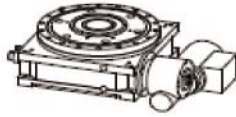

1SL90



1SL180



2SL90



2SL180

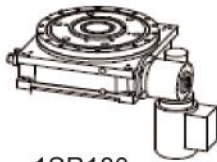

1SR180



1SR270

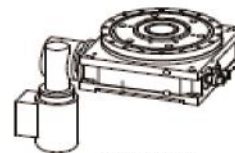

2SR180



2SR270

NOTE



Always follow the original operating instructions of the drive manufacturer on mounting the drive (Standard SEW) to the cylinder cam rotary indexing table. Oil control – and drain bolts as well as air escape valves must be freely accessible without mechanical intervention.



6.2 Installation and commissioning

6.2.1 Safety information

DANGER



DANGER! **Risk of death by electrocution!**

There is an immediate risk of fatal injury due to electric shock if live components are touched.

Damage to the insulation or to individual components can cause fatal injury.

- ▶ Only allow work on the electrical system to be carried out by qualified electrical engineers.
- ▶ In the event of damage to the insulation, immediately shut off the power supply and initiate a repair.
- ▶ Before starting work on active parts of the electrical system or equipment, ensure that it is completely powered down and cannot be switched on again.

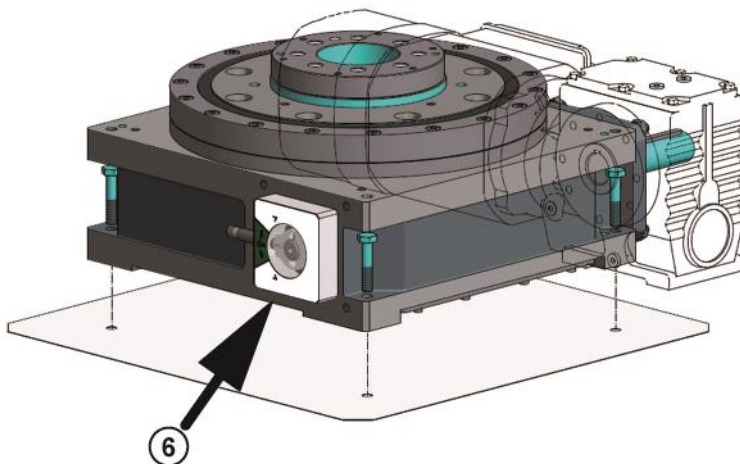

Figure: Installation orientation Type RT and TT
(6) Side 6

NOTE



The standard installation orientation for the cylinder cam rotary indexing table is always with its side (6) facing down (horizontal). Other installation orientations only in consultation with Motion Index Drives.

6.2.2 Installation

Staff: Qualified staff

- ▶ The surface on which the machine is to be installed must be level.
- ▶ Clean the installation surface and apply a film of oil.
- ▶ Place the Cylinder Cam Rotary Indexing Table TMF on the installation surface.
- ▶ Secure the Cylinder Cam Rotary Indexing Table TMF with screws and studs according to requirements.
- ▶ Compare the power supply with the details on the rating plate.
- ▶ Connect the drive unit.
- ▶ The housing of the Cylinder Cam Rotary Indexing Table has to be earthed consistently according to the VDE regulations with adequate width



Securing the drive

The drive must be secured with bolts at the specified points. It is possible to connect a servo motor or a three-phase motor to the cylinder cam rotary indexing table.

On request, Motion Index Drives can supply an adapter flange for use between the drive and the RT and TT housing.

The input shaft must not be remachined. The diameter and length of the hollow shaft of the drive are determined by the dimensions of the input shaft (refer to the dimensions sheet for information).

Accessories on the star wheel

- Observe the following constraints when attaching accessories to the star wheel:
- Maximum weight moved (as per Motion Index Drives project planning)
- Minimum positioning time (as per Motion Index Drives project planning)
- Maximum overhang (tipping moment) (as per Motion Index Drives project planning)
- Maximum tightening torque for securing holes, see torque table.

Torque table

Steel bolts	Torque [Nm]
Quality grade	
8.8	
M4	3.3
M5	6.5
M6	11.3
M8	27.3
M10	54
M12	93
M14	148
M16	230



6.3 Adjustment of the position cam series S01

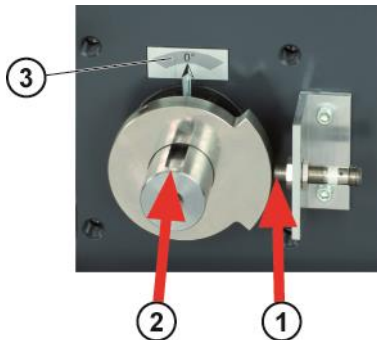

Figure: Detail position cam

- (1) Middle of switch flag aligned with the sensor.
- (2) Correct setup of the switch cam.
- (3) Decal (The grey area of the decal is only symbolic and does not indicate the length of the dwell phase.)

The position cam is secured in place by means of two radial screws on the drive shaft. It is correctly set up when the keyway and the pointer point to the zero reference mark on the decal (2) and the middle of the switching flag is aligned with the sensor (1).

6.3.1 Minimizing time losses

Depending on the speed of the rotary indexing table, the dwell phase can be a few hundredths to several tenths of a second. If the drive is stopped right at the beginning of the dwell phase, in the following cycle you will lose the time the drive requires to carry out the rest of the dwell phase.

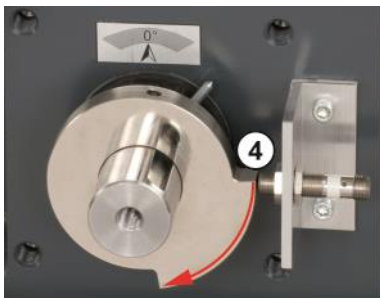

Figure: Detail delayed shutdown

- (4) Ideal breakpoint at the end of the position cam

Time-optimized control of the rotary indexing table means starting the external machining right at the start of the dwell phase (rising flank on the position sensor) and allowing the motor to turn for a short time for it to come to a standstill shortly before the end. (4). No time in the next cycle is lost!
You need a second switch cam to get time optimized control.

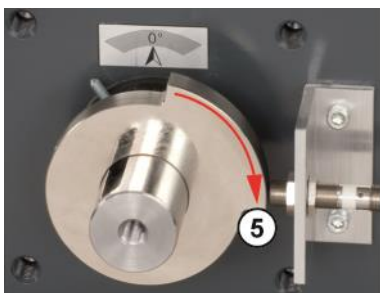

Figure: Detail delayed shutdown

- (5) Stop immediately with the rising flank

With continuous reversing operation always stop with the rising flank of the position sensor since the dwell phase is left again in the opposite direction.



7 Service and maintenance

The machine is designed to be largely maintenance-free. Necessary maintenance is intended to keep the machine fit for service. The intervals will depend on the operating conditions.

Note:

The maintenance intervals given are minimum recommendations based on use across three shifts. Failure to observe the maintenance stipulations and any changes will make the guarantee null and void and release the manufacturer from any liability.

Make sure that you observe any statutory requirements, stipulations and national regulations in respect of occupational health and environmental protection.

The maintenance stipulations only apply in conjunction with the operating instructions of the manufacturer concerned. The contents are subject to change without notice.

7.1 Safety information in respect of maintenance

WARNING



WARNING!

Danger if staff are insufficiently qualified!

Persons who are inadequately qualified are unable to assess the risks associated with working on the machine and expose themselves and others to the risk of serious or fatal injury.

- ▶ Ensure that all work is performed only by suitably qualified persons.
- ▶ Keep insufficiently qualified persons at a safe distance from the working area.

7.1.1 Qualified staff required

The operator must unambiguously specify who is responsible for cleaning, maintenance and servicing and how such work is to be performed.

Only allow qualified, trained and properly instructed staff to work on the machine.

7.1.2 Maintenance tasks

If servicing work is to be performed in-house, the appropriate tools and equipment for such work must be provided.

Follow the procedures laid down in the Operating Instructions for switching the system on and off when performing any maintenance and cleaning work.

Observe the stipulations laid down in the Operating and Maintenance Instructions with respect to adjustment, maintenance and servicing activities, including details on replacing components and equipment.

Where necessary, cordon off the area in which maintenance is being carried out at a safe distance.

7.1.3 Cleaning

Make sure that all handles, steps, handrails, platforms, ladders are clean.

Compressed air must not be used for cleaning.

Before starting maintenance work, clean any oil, fuel or cleaning agents from the machine, and particularly from connections and screwed joints. Do not use aggressive cleaning agents. Use lint-free cloths.

After cleaning, check all supply lines to ensure that they do not leak, that no connections have come loose, and that they show no signs of abrasion or damage. Immediately rectify any faults.

Concluding work

Always tighten any screw connections that have been released during maintenance and service work. If safety equipment has to be removed during setup, maintenance or repairs, the safety equipment must be replaced and tested immediately work has been completed.

Dispose of service fluids, process materials, cleaning agents and used parts safely and in an environmentally friendly manner. Follow the manufacturer's instructions when dealing with hazardous substances.



Replacement parts

Replacement parts must comply with the technical requirements laid down by the manufacturer. This is guaranteed with original replacement parts.

Environmental protection

Take note of the following environmental protection information when carrying out maintenance work:

- ▶ Remove excess grease from the lubrication points and dispose of it in accordance with local regulations

7.2 Maintenance tasks

7.2.1 Maintenance plan

Interval	Maintenance activity	Staff
Daily	General visual and acoustic inspection	Operator
Monthly	Check that no oil is escaping from the cylinder cam rotary indexing table.	Operator
Monthly	Check oil level.	Operator
Monthly	Lubricate the rotary indexing table Typ RT400, Typ RT500, Typ RT630, siehe Seite 48.	Qualified staff
Three-monthly	Visual inspection for damage. Remove any dust deposits (especially on ventilation grills of the drive units). Inspect electric cables for damage.	Qualified staff



7.3 Checking the oil level

The Cylinder cam rotary indexing table of type TT075-TT315 and RT100-RT250 are life- time lubricated.

The Cylinder cam rotary indexing tables of type RT400 on are equipped with an oil sight glass an must be serviced according to the maintenance plan.

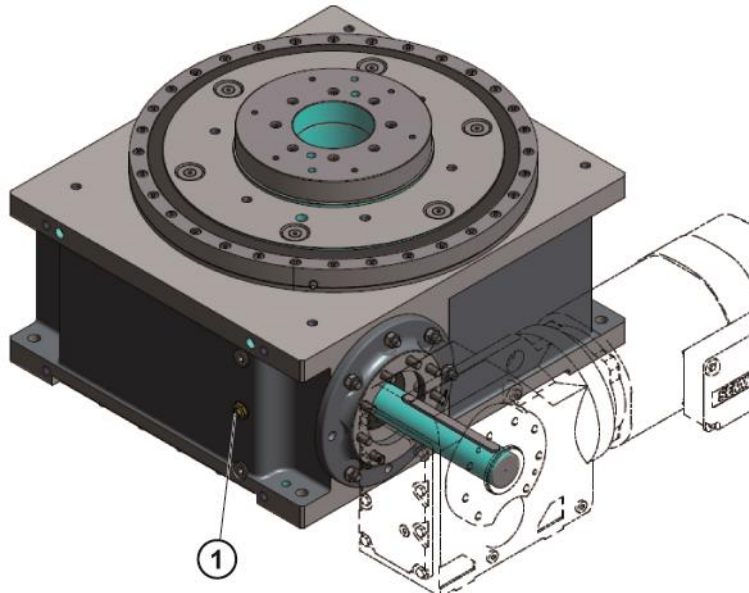

Figure: Checking the oil level

(1) Oil sight glass

- ▶ Check oil level.
- ▶ Top up oil as required.



7.4 Lubrication

7.4.1 Requirements for lubricants

General

To ensure safe operation and a long service life, it is necessary to lubricate the machine carefully. The specified oil and grease must be applied to all lubrication points. Carefully clean dirty lubrication points using a suitable agent and then lubricate them with new lubricant. After lubrication, any excess lubricant must be removed and properly disposed of. The oil and grease used must be silicone-free.

Lubricating oil

Use only lubricating oil compliant with DIN 51 517
Recommended gear oil: Mobil – Mobilgear600XP460 (ISOVG460)

Lubricating grease

Use only lubricating grease compliant with DIN 51 825-KP 2K

Recommended lubricating grease: Mobil – Mobilux EP2

Note:

Only use lithium soap-based grease for lubrication. The use of greases based on different materials causes gummy deposits, decomposes the grease and destroys its lubricating properties.

7.4.2 Lubricating the rotary indexing table Type RT400, RT500, RT630

Monthly maintenance

Staff: Qualified staff

Tools and accessories required

Grease gun with adapter
Lubricating grease: Mobil – Mobilux EP2

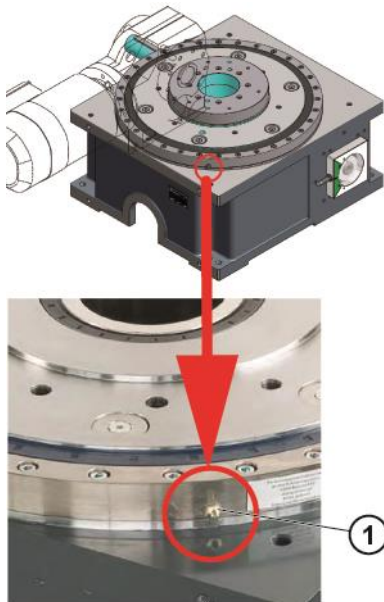

Figure: Detail showing grease nipple

(1) Grease nipple

- ▶ Apply grease to the grease nipple (1) using the grease gun.
- ▶ Remove excess grease.

7.5 Replacing cam follower

The cylinder cam rotary indexing table must first be isolated from the power supply to allow the Taktomat cam follower (TKR) to be removed and maintained safely and efficiently. Any external accessories that obstruct access to the cam follower must be removed correctly.

The following assembly sequence must be strictly adhered to

7.5.1 Replacing cam follower assembly sequence

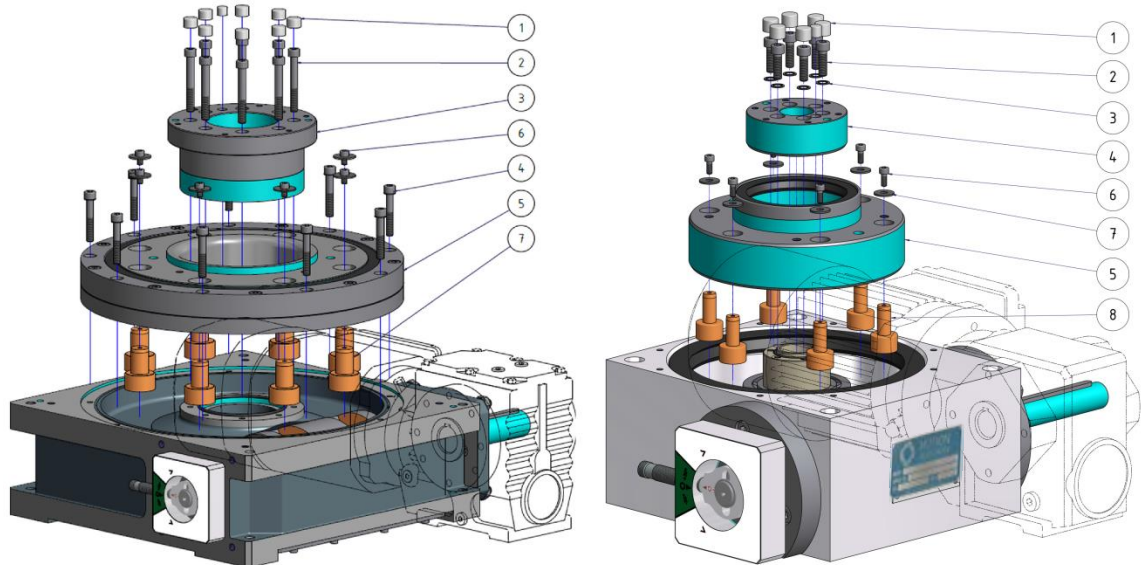

Figure: Detail assembly sequence
(1) to (8) Sequence of work steps RT und TT.

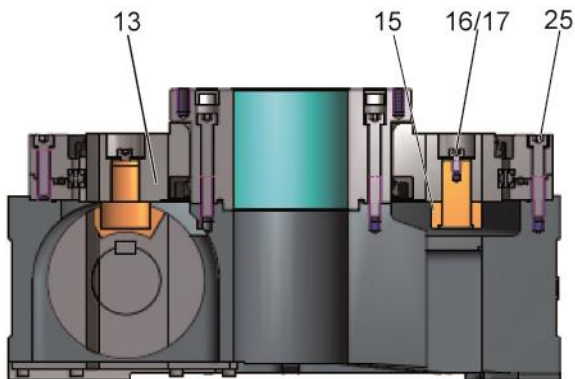
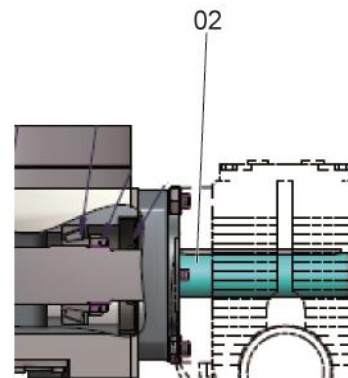

Figure: Detail replacing cam idler



- | | |
|--------------|---------------------|
| 02 | Input shaft (drive) |
| 13 | Star wheel (output) |
| 15 | Cam follower |
| 16/17 | Bolt + Disk |
| 25 | Long bolts |



Step	Action
(1)	▶ Turn input shaft 02 to the middle of the dwell. In the standard version, the grooves of the keyways point upwards.
(2)	▶ Loosen long screws 25 from the four-point-contact bearing of the casing (every second screw).
(3)	▶ In an upward direction, pull out the drive flange 13 with appropriate sling equipment.
(4)	▶ Check cam followers.
(5)	▶ Loosen the locking screws 16/17 on cam followers that has to be replaced
(6)	▶ Remove cam follower 15 . Replace the damaged and the two adjacent cam followers.
(7)	▶ Re-assemble in reverse order.



8 Troubleshooting

8.1 Safety information

DANGER



DANGER! **Risk of death by electrocution!**

There is an immediate risk of fatal injury due to electric shock if live components are touched.

Damage to the insulation or to individual components can cause fatal injury.

- ▶ Only allow work on the electrical system to be carried out by qualified electrical engineers.
- ▶ In the event of damage to the insulation, immediately shut off the power supply and initiate a repair.
- ▶ Before starting work on active parts of the electrical system or equipment, ensure that it is completely powered down and cannot be switched on again.

WARNING



Risk of injury from improper troubleshooting!

Improper troubleshooting can cause serious injury to staff and material.

- ▶ Before starting work ensure that there is sufficient room to carry out the work.
- ▶ Pay attention to tidiness and cleanliness in the working area! Loose parts and tools, which are piled up or lying around, are sources of accidents.



9 Disposal

At the end of its service life, the machine must be disassembled and disposed of in accordance with environmental protection requirements.

9.1 Disassembly

Before starting disassembly:

- ▶ Disconnect all power supply to the machine and ensure that it cannot be reconnected.
- ▶ Disassemble assemblies and components, observing any local environmental protection regulations.

9.2 Disposal

- ▶ If no return or disposal agreement has been concluded, dispose of the components in a recycling facility after they have been properly disassembled.
- ▶ Scrap metal parts.



10 Replacement parts and consumables

Replacement parts must meet the manufacturer's technical specifications. This is always ensured if original replacement parts are used.

10.1 Replacement parts and consumables Type RT

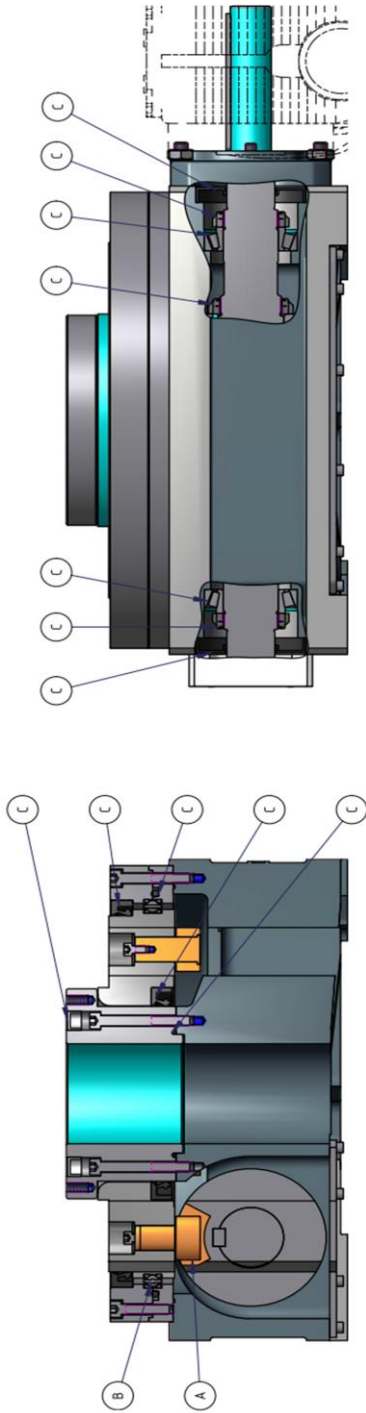

Figure: Overview Replacement parts and consumables Type RT

No.	Designation	RT100S03 Item no.	RT160S03 Item no.	RT200S03 Item no.	RT250S03 Item no.	RT400S03 Item no.	RT500S03 Item no.	RT630S03 Item no.	SP/ WP
A	Taktomat Cam idler 2 Stop (TKR)	308712	300281	300281	300281	305590	304998	317137	WP
A	Taktomat Cam idler 3 Stop (TKR)	300282	300281	300281	300281	305590	304997		WP
A	Taktomat Cam idler 4 Stop (TKR)	300282	300281	300281	308800	305820	317275		WP
A	Taktomat Cam idler 5 Stop (TKR)	300282	301233	300281	308800	305820			WP
A	Taktomat Cam idler 6 Stop (TKR)	313237	301233	300281	308800	305820			WP
A	Taktomat Cam idler 8 Stop (TKR)	313237	301233	300281	308800	305820			WP
A	Taktomat Cam idler 10 Stop (TKR)	313237	301233	300281	308800	305820			WP
A	Taktomat Cam idler 12 Stop (TKR)	300282	301233	300281	308800	305820			WP
A	Taktomat Cam idler 16 Stop (TKR)	313237	301233	300281	308800	305820			WP
A	Taktomat Cam idler 20 Stop (TKR)	313237	301233	300281	308800	305820			WP
A	Taktomat Cam idler 24 Stop (TKR)	300282	301233	300281	308800	305820			WP
A	Taktomat Cam idler 30 Stop (TKR)	300282	301233	300281	308800	305590			WP
A	Taktomat Cam idler 36 Stop (TKR)	313237	301233	300281	308800	305820			WP
B	Central bearing	301107	301097	313804	301123	303413	323718	307020	WP
C	Assembly kit (includes bearings and sealings)	324763	325038	323761	323504	323612	317800	312054	SP/ WP



10.2 Replacement parts and consumables Type TT

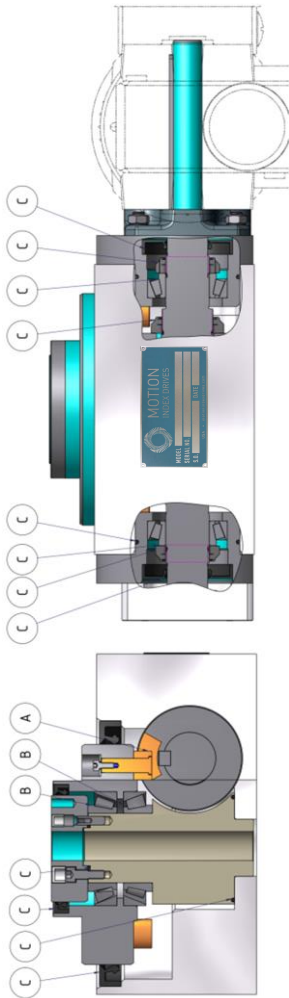

Figure: Overview Replacement parts and consumables Type TT

No.	Designation	TT075S03 Item no.	TT125S03 Item no.	TT250 Item no.	TT315S03 Item no.	SP/ WP
A	Taktomat Cam idler 2 Stop (TKR)	308712	308712	300281	305590	WP
A	Taktomat Cam idler 3 Stop (TKR)	301615	308712	-	-	WP
A	Taktomat Cam idler 4 Stop (TKR)	308712	313237	300281	305590	WP
A	Taktomat Cam idler 5 Stop (TKR)					WP
A	Taktomat Cam idler 6 Stop (TKR)					WP
A	Taktomat Cam idler 8 Stop (TKR)					WP
A	Taktomat Cam idler 10 Stop (TKR)					WP
A	Taktomat Cam idler 12 Stop (TKR)					WP
A	Taktomat Cam idler 16 Stop (TKR)					WP
A	Taktomat Cam idler 20 Stop (TKR)					WP
A	Taktomat Cam idler 24 Stop (TKR)					WP
A	Taktomat Cam idler 30 Stop (TKR)					WP
A	Taktomat Cam idler 36 Stop (TKR)					WP
B	Central bearing	301497	300305	300304	305352	WP
C	Assembly kit (includes bearings and sealings)	-	311283	304590	303270	SP