

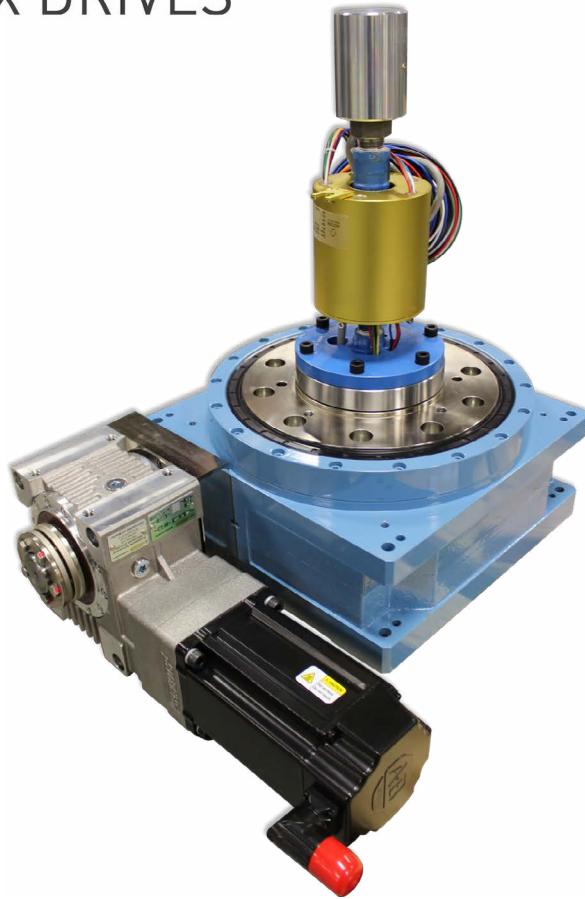

MOTION
INDEX DRIVES



RT Indexer

Operating Manual

Table of Contents

1. Safety instructions	3
1.1. General	3
1.2. Validity of this documentation	3
1.3. Intended use	3
1.4. Installation	4
1.5. Transport and Storage	4
1.6. Identification Plate	4
1.7. Electrical Connection	4
1.8 Lifting and Lubrication & Oil and Grease Type Tables	5
2. Assembly and Mode of Operation	6
2.1 Programmable Index Drive	6
2.2. Fixed Index Drives	6
Operating Modes	7
3.1. Operation of Programmable Index Drive	7
3.1.1. Normal Operation	7
3.1.2. Jogging Operation	7
3.1.3. E-Stop Operation/Stopping out of Position	7
3.2. Operation of Fixed Index Drives	8
3.2.1. Normal Operation	8
3.2.2. Intermittent Operation	8
3.2.3. Continuous Operation	8
3.2.4. Continuous Reversing (Oscillating) Operation	8
3.2.5. Jogging/Inching Operation	8
3.2.6. Emergency Stop	8
4. Machine Commissioning Fixed Indexers	9
4.1. Overview	9
4.2. Setup	9
4.3. Final Check	9
5. Controlling the System (Fixed Index Drives)	10
5.1. Adjusting the Position Cam	10
5.2. Continuous Operation - Single Direction	11
5.3. Two or Four Station (180° or 90° Reciprocating) Operation	11
5.4. Visual Pin Indicator	11
5.5. Limit Switch Adjustments	11
6. Operation of Fixed Index Drive with VFD	12
6.1 Normal Operation	12
6.2 Jogging Operation	12
6.3 E-Stop Operation/Stopping out of Position	12
7. Cycle Times	13
8. Speeds	13
9. Maintenance	14
9.1. Maintenance	14
9.2. Inspection	14
9.3. Overhauling	14
10. Spare Parts and Wear Parts	15
11. Sew Euro-Drive Common Motor & Brake Rectifier Connection	16



1. Safety instructions

1.1. General

Before you install and start operating this index table, please read these safety and operation instructions carefully. You should also read all warning signs on the devices and bear in mind, that they may not be damaged, nor may they be removed. The installation, initial operation, and maintenance may only be carried out by qualified technical personnel. According to these safety instructions, persons are qualified who are familiar with the installation, assembly, start-up, operation, and maintenance of automated systems, and possess the appropriate qualifications. Safe operation of these devices depends on correct application. Keep the safety and operations instructions in an accessible place, and make it available to all personnel who have any kind of access to the devices. Disregard of this and other instructions contained within this book may cause the operator and the system to be exposed to danger, and this can lead to danger to the equipment, severe injury, or even death.



The index table may only be put into operation after the entire system in which it is integrated as well as the control and safety system conform to the machine guidelines and the appropriate domestic standards at the place of installation and operation.



Crushing Hazard. Keep adequately safe distance from moving parts!



Adhere to appropriate accident prevention regulations as well as generally acknowledged safety and occupational health regulations. Inadmissible modifications and the use of replacement parts and auxiliary equipment which are not recommended by the manufacturer can result in injury or material damage.



Before any work is done on the rotary table and its components, the drive is to be powered down and locked out against independent restarting!

Instructions: This operating manual was published in April 2013. The information contained within this documentation is the property of Motion Index Drives (MID), and may not be copied, reproduced, or forwarded to third parties without express written permission. With regard to the use of the information contained herein, no liability will be accepted. Furthermore, the information contained within this documentation can be changed without notice, since MID is constantly developing its high-quality products and gaining new insights. This operating manual has been drawn up with all necessary accuracy. MID accepts no responsibility for any errors or omissions, nor will any liability related to damages which result from the application of the information contained in this publication be accepted.

The CE certification is based on the following standards:

- EG machine guideline 98/37/EG
- EG low voltage guideline 93/68/EWG
- ER guideline for electromagnetic compatibility 89/336/EWG

1.2. Validity of this documentation

This operating manual is valid for all rotary index tables produced by Motion Index Drives, Inc.

1.3. Intended use

The sizing of the rotary table are to be carried out according to the tables and calculations displayed in this manual, and shall be carried out by technical sales personnel of MID.



The rotary index tables described herein are intended for use in normal industrial plants. They may not be installed into machines and equipment whose failure could put human lives directly at risk or cause great losses.

Standard units not to be used in an explosive environment. Any use of a rotary index table where safety may be in doubt is not permitted! Please contact Motion Index Drives before using the index table in such an environment as to ensure electrical components are suited for specific environments.



MOTION INDEX DRIVES

1.4. Installation

Rotary index tables must be installed in accordance with regulations outlined in the documentation. The installation position is user defined, and must be disclosed to MID when ordering the rotary index table.

Check before installation that the delivery is complete and correct.

Please verify that the rotary index table is correct by checking the identification plate, see Figure 2.

1.5. Transport and storage

Generally, rotary index tables should be stored and installed in a dry, clean environment. When transporting, only use means of transport and hoisting gear that has been approved for the weight of the rotary index table in question. In order to lift the rotary index table, please use three or more eye bolts. Tapped holes provided. (See table 1.1 for proper size)

1.6. Identification plate

The following information can be found on the ID plate:

1.7. Electrical connection (only applies if the drive is included)



Work on the electrical installation may only be carried out by trained specialists. Please adhere to all technical and country-specific regulations and standards during the installation. Our rotary index tables are driven by three-phase brake motors as standard. Connect the motor and brake only to the power supply as specified on the type plate. The motors must be protected from overload by means of motor overload switches or other suitable protective devices.

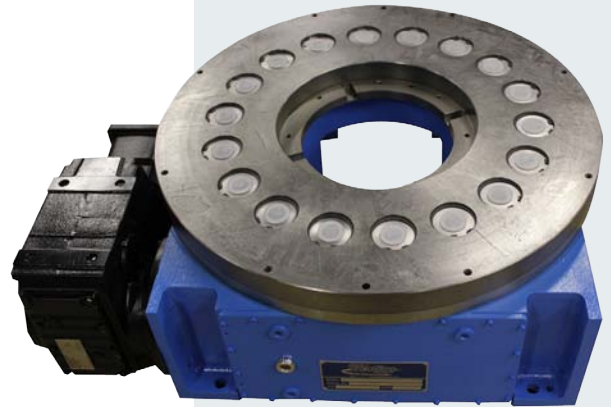

Figure 1

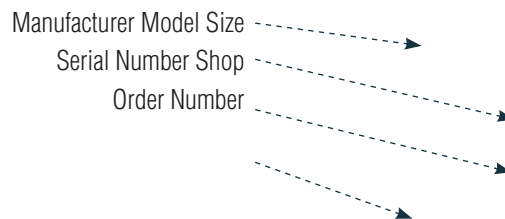
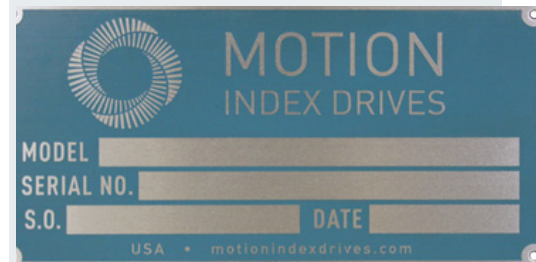

Figure 2





1.8. Lifting and Lubrication & Oil and Grease Type Tables Table 1.1 Lifting and Lubrication

MODEL	WEIGHT LBS (APPROX)	WEIGHT KG (APPROX)	BOLT SIZE	BOLT QTY.	MAX OIL CAPACITY (L)
RT100	95	43	M8	4	0.3
RT160	150	70	M8	4	0.6
RT200	250	113	M8	4	0.75
RT250	320	145	M10	4	1.0
RT400	1300	590	M16	4	9.5
RT500	2500	1136	M20	4	18.5
RT630	4550	2068	M20	4	30
RT900	6500	2950	M24	4	50
TSR600	506	230	M16	2	1
			M8	8	
TSR1000	1188	540	M16	2	9,5
			M10	12	
TSR1600	1815	825	M24	2	17
			M10	14	
TT075	26.4	12	M6	4	0,45
TT125	52.8	24	M6	8	0,45
TT250	176	80	M10	4	1,1
TT315	411.4	187	M12	4	4,5
TMF1000	300	140	M12	12	1.1
TMF2000	7930	420	M12	12	4,5
TMF3000	1760	800	M12	14	7,5
TMF4000	2860	1300	M12	30	9
TMF5000	3300	1500	M12	36	11
TMF8000	13650	6200	M16	40	40

Table 1.2 (Oil and Grease Types)

MANUFACTURER	GEAR OIL		LOW-VISCOSITY GEAR GREASE		GREASE FOR BALL AND ROLLER BEARINGS
	Mineral Oil Basis	Synthetic Oil Ba-sis	Mineral Oil Base	Synthetic Oil Ba-se	Lithium-saponied
BP	Energol GR-XP 460	Energol SG-XP 460	Energol EP 0	Biogrease EP 0	Energol LS2
DEA	Falcon CLP 460	Polydea PGLP 460	Glissando 6833 EP 00	N/A	Glissando FT2
ESSO	Spartan EP 460	Umlaufol S 460	ESSO Getriebefliefett	Fliefbett S 420	Beacon 2
Fuchs	Renolin CLP 460	Renolin PG 460	Renosod GFB	Renax GLS 00	Renolit FEP2
Kluber	Kluberoil GEM 1-460	Syntheso D 460 EP	Mobillex 44	Klubersyn GE 46-1200	Microlube GL 262
Mobil	Mobilgear 634	Glygoyle 460 HE	Microlube GB 00	Glygoyle Grease 00	Mobilux 2
Shell	Omaha OI 460	Tivela OI SD	Spez-Getriebe-fett H	Tivela Compound A	Alvania R2

Duration of Oil Change	In general the oil in the Rt Series does not have to be changed. Please contact Motion Index Drives for detailed information regarding your application requirements.
Grease Intervals	All series larger than RT250 require monthly greasing. All over models RT250 and smaller are completely maintenance free.



2. Assembly and mode of operation

2.1. Programmable Index Drives

The rotary index table transforms a constant input drive motion into a constant output drive motion. The drive motion occurs by means of a flame or induction hardened and high-accuracy milled constant lead barrel cam. The use of mathematical laws of motion along with a properly programmed motor profile (see section 3.1) guarantee a soft, shock proof and jerk free movement that has been optimally designed for its intended purpose. The designed assembly allows for accurate and secure mounting to the output dial which is also backlash free. No additional adjustment of the output dial is necessary. Any additional modification to the index drive unit can result in damage to the indexing device.

The power to rotate the index drive is provided either by means of a three phase AC motor with encoder, coupled to a gear reducer, or a servo motor coupled to a gear reducer.

The gear reducer is connected to the input shaft which is firmly connected to the internal barrel cam with no further internal gearing. The barrel cam in turn rotates the top dial through the cam followers with a zero backlash internal design. The output dial is mounted to a wire bearing assembly (4 point contact bearing), which is preloaded to eliminate any runout. The index drive is completely sealed to eliminate intrusion from foreign particulate matter and fluids.

2.2. Fixed Index Drives

The rotary index table transforms a constant input drive motion into an intermittent output drive motion. The intermittent drive motion occurs by means of a flame or inductively hardened and high accuracy-milled barrel cam. The use of mathematical laws of motion guarantees a soft, shock-proof and jerk free movement that has been optimally designed for its intended purpose. The designed assembly allows for accurate and secure mounting to the output dial which is also backlash free. No additional adjustment of the output dial is necessary. Any additional modification to the index drive unit can result in damage to the indexing device. (see section 3.2)

The power is provided either by means of a three-phase brake motor via a gear reducer or by means of a chain-wheel or belt-wheel on the drive shaft of the rotary index table. This is firmly connected to the barrel cam, without any further internal gear sets, and it turns the cam followers and subsequently the output flange. The output flange is mounted within a wire bearing assembly, backlash free of play (within steel ring - not in casting). The index drive is completely sealed to eliminate intrusion from foreign particulate matter and fluids.

(Please see section 3 for proper utilization of fixed index drives)

Cam Follower Carrier

Barrel Cam
(Fixed Index Drive)

Dwell Phase
(Fixed Index Drive)

Indexing Phase
(Fixed Index Drive)

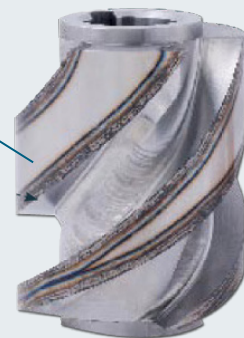
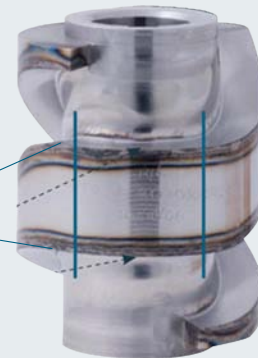
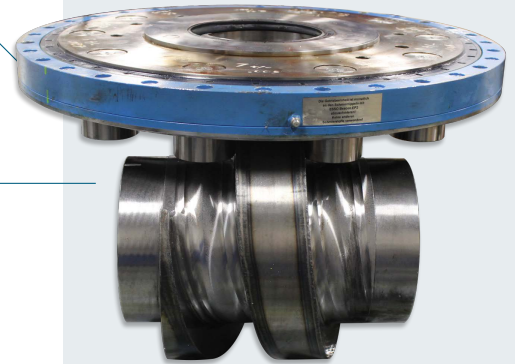

3. Operating Modes

3.1. Operation of Programmable Index Drives

All programmable index drives must be run on a VFD/Amplifier. The following MUST be followed to ensure proper operation and to prevent immediate and irreversible damage to the index drive.

3.1.1. Normal Operation

Normal Operation is defined as starting and stopping the index drive from two fixed points, or from position to position. Normal operation is the primary operation the index drive will function.

In Normal Operation, the index drive will have three unique speeds during one cycle. The unique periods are as follows:

ACCELERATION: This is the time the motor and index drive run from zero speed, 0 Hz, to a peak speed. The acceleration time should never be less than 0.5 seconds for a programmable index drive. Motion Index Drives will provide the acceleration time recommended for your VFD/Amplifier parameters. The peak speed to accelerate to will also be provided for your application, traditionally set to 60 HZ MAX!

CONSTANT VELOCITY: This is the time the motor runs at a constant speed, once acceleration is complete. This time is determined on an application by application basis. In some cases, there is 0 seconds constant velocity, please check with Motion Index Drives, Inc. for your application. Total Index Time minus acceleration and deceleration time is equal to the constant velocity time.

DECELERATION: This is the time the motor and index drive run from peak speed (60HZ normal) to 0 Hz, or zero speed. This time is determined on an application by application basis. The deceleration time should never be less than 0.6 seconds.

NORMAL OPERATION PARAMETERS:

Acceleration: 0.5 seconds or more - Application Dependant

Deceleration: 0.6 seconds or more - Application Dependant

Frequency: Based on customer application. Never exceed 60Hz max motor frequency unless otherwise instructed by Motion Index Drives, Inc.

EXCEEDING MOTION INDEX DRIVES RECOMMENDED FREQUENCY AND/OR JUMPING FREQUENCIES DURING NOR-MAL OPERATION WILL IMMEDIATELY VOID WARRANTY.

3.1.2. Jogging Operation

Jogging is defined as rotating the index drive in a slow, manual mode. This is typically done in the initial setup.

For jogging, it is recommended to run the index drive at a much slower frequency (i.e. 20HZ), and accel/decel rates are suggested at 0.5 seconds.

3.1.3. E-Stop Operation/Stopping out of Position

E-stop conditions are defined as the immediate stop of the index drive due to one of many factors, including opera-tor light screen or safety mat being activated, robot errors, or e-stop buttons being activated and involve the requi-rement of the index drive to stop out of a programmed position. Operating the index drive properly with a VFD/Amplifier during e-stops, or stopping out of position is critical to ensuring the indexers operation. During the e-stop, if dynamic braking is being utilized in the VFD/Amplifier, ensure that the dynamic braking time is not any less than 0.6 seconds. Longer braking time is acceptable. During e-stop, it is critical to ensure that the dynamic brake is not driving through the brake of the motor if the motor is equipped with one. The brake circuit should be applied after the dyna-mic braking time. To restart from an e-stop or out of position stop, it is suggested to accelerate the motor to the peak motor frequency if applicable using the same acceleration time provided in normal operation. The same decelerati-on time should also be followed when approaching the next known position in the normal operation mode.

E-stop/Stopping Out of Position Parameters:

Acceleration: 0.5 seconds or more – Application Dependant

Deceleration: 0.6 seconds or more - Application Dependant

Frequency: Based on customer application. Never exceed 60HZ max motor frequency unless otherwise instructed by Motion Index Drives, Inc.

Dynamic Brake Time/Decel Time during e-stop: >0.6 seconds



Warning: It is imperative that the controls individuals understand this operation prior to commissioning an index drive. For any questions, please contact Motion Index Drives, Inc. prior to commissioning index drive to prevent irreversible damage to the index drive from improper operation. Improper operation of the index drive with variable frequency drive will immediately void warranty!



Warning: Motors supplied w/brake: Brake is only used for holding position and should NEVER be used for stopping indexer under normal conditions or during an emergency stop!



3.2. Operating of Fixed Index Drives

3.2.1. Normal operation

Normal operation is understood to be the movement of the output flange in a direction from one dwell position to the next. The rotational direction of the output flange is determined by the rotational direction of the drive. With a three-phase motor this can easily be reversed by swapping two phases of the supply voltage.

3.2.2. Intermittent operation

The drive shaft stops in the dwell phase. The index time is fixed. The dwell period is variable. This mode of operation is used in plants with much longer processing times than rotating times and is the most common mode of operation.

3.2.3. Continuous operation

The rotary table runs continuously without the motor stopping. Index and dwell times are fixed and run through continuously. The drive motor has only one rotational direction. This mode of operation is frequently used in high production applications which require short processing times. The rotary index table is synchronized to the rest of the system mechanically by means of a free drive shaft. The relationship between dwell and index time can be adjusted within certain limits by Motion Index Drives, Inc. when producing the cam.

3.2.4. Continuous Reversing (Oscillating) Operation

The drive of the index table is always reversed in the dwell phase. With this kind of mode of operation, the drive flange switches backwards and forwards between two positions. With rotation angles less than 90° on the drive flange, the cam can be constructed in such a way that continuous reversing operation is possible without the direction of the drive being reversed.

3.2.5. Jogging/Inching Operation

With inching operations, the drive flange moves in small steps between two dwell positions. Under these conditions, the barrel cam cannot gently accelerate and decelerate the built load. This puts the internal components under stress, since any acceleration that occurs during the inching operation far exceeds the forces realized during normal operations. Without any suitable rotary index table controls that allow gentle acceleration and braking of the load outside the dwell phase, inching operation is not permitted. Any jog/inching operation outside the dwell period of the cam the controls can only run the motor in half speed mode.

3.2.6. Emergency Stop

Emergency stop is comparable with the stopping in jog mode operation. Here, too, the stopping and re-starting of the built-up load occurs outside the dwell phase. Frequent emergency stop situations should be avoided as much as possible. Excessive E-stops will void warranty!



If using NFD w/fixed index drive, reference section 6 for proper setup.



4. Machine Commissioning Fixed Indexers

4.1. Overview

Most indexing machines run on a step by step principle. In this configuration, stoppage time is variable and independent from the rotation time. For a step by step actuation, we choose the widest indexing angle to reach the lowest pressure angle. The angle of the cam stoppage (dwell) located inside the indexing unit is directly linked to the braking time of the motor brake unit. The motor stoppage is triggered by a control cam located outside the indexing unit which actuates an end stroke signal or a sensor as the output shaft of the table is in a dwell phase (cam fol-lowers in the locking (dwell) area of the cam).



Warning: Always control the motor stoppage with a hardware solution.

4.2. Set Up

Turn the input shaft until the mounting holes of the output shafts are in the axis of the indexing table. The same principle applies to the keyway on the output shaft. Before counter drilling the output table, arm or other parts on the output shaft, make sure that table, handler and index drive are set up in the dwell period - the colored arrow indicator will be facing the colored sector.



Warning: Never control the brake motor stoppage by an end of stroke sensor located at the indexing table output (output shaft area or tooling). In any case, the only stoppage control to be driven by the end of stroke sensor is located on the input shaft (Figure 3).

Our indexing drives are delivered with the motor off control cams and limit switches that are pre-set for no load conditions. These motor off cams may need to be adjusted by the customer depending on the response time of the index drive once the unit is completely tooled and operating at high speed. This has to be set at the integration source to ensure the unit stops in the middle of the dwell as indicated in Figure 4.

The motor off cam may need to be finely adjusted multiple times in order to get the unit to stop in the middle of dwell. This can only be done using trial and error. This is due to the index drive's stopping point being driven by the inertia the indexer has to stop.



Warning: Before motor start up, make sure that no one and no tooling is in the dangerous area.

4.3. Final Check

Make sure real life tooling weights and measurements match what was provided to Motion Index Drives and have not changed since the latest loading information was provided. In addition, check the following during your indexer's first start:

1. Actuation of the dwell switch is working correctly
2. Electric wiring of motor and brake rectifier
3. Brake is releasing when motor is turned on (see section 11 for brake control setup)

Figure 3

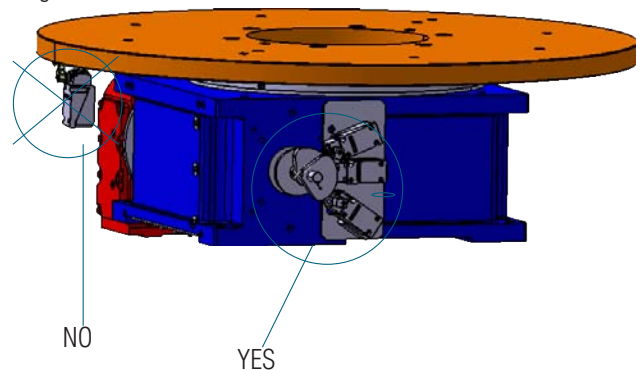

Figure 4





5. Controlling the System (Fixed Index Drives)

In order to control the rotary index table, the drive cam is fitted with a position cam. The length of the dwell area corresponds to the length of the dwell phase in the drive cam. The drive flange is in a securely locked position when the sensor is somewhere in the area of the dwell area. In order to synchronize the rotary index table, the brake and motor voltage have to be applied. The drive turns and the switching flag of the position cam leaves the sensor area. If the sensor is activated again, the drive flange, depending on the index angle of the rotary index table, will move to the next dwell position and the motor and brake will be switched off. (Brake voltage off = brake active; Brake is mechanically engaged, electrically released)

Keep checking that the dwell cam comes to a stop within the sensor area and is left where it is sensed by the switch.



Faulty motor contractors (jammed mechanical or burnt out electronic contacts) prevents the drive motor from being switched off. This could lead to severe personal injury or damage to property. Initiate an emergency stop immediately.

5.1. Adjusting the position cam (If Applicable with Proximity Sensor)

The position cam is secured by two frontal screws on the drive shaft. It is properly adjusted if the key groove of the drive shaft shows the zero position on the sticker and the middle of the switching cam is positioned at the sensor. (see figure 7)



The grey area of the decal is only symbolic and does not indicate the length of the dwell phase.

Correctly adjusted position cam. The zero position of the sticker and the feather groove key point to each other and the middle of the position cam's switching cam is at the center.

If the sticker is missing, the feather key groove points upward to the drive flange when the circular table is in mid-rest position.



Do not alter position cam location. Rotating position cam can lead to stopping out of position, which will void warranty. Position cam is preset at Motion Index Drives to read accurate dwell position.

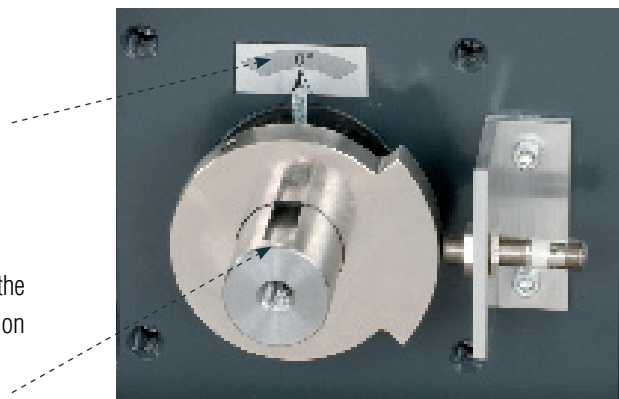

Figure 7

Limit Switch Setup (If Applicable)

5.2. Continuous Operation - Single Direction

(1) Lever type limit switch (LS1):

Provided for high speed motor stop. This switch has an adjustable switch actuation cam.

(1) Lever type limit switch (LS2):

Provided for low speed motor stop. This switch has an adjustable switch actuation cam.

(1) Plunger type limit switch (LS3):

Provided for dwell confirmation. This is a non-adjustable switch, with a non-adjustable switch actuation cam pin-ned to the index drive limit switch shaft.



Warning: Motion Rotary Index Drives are designed to run production in high speed at all times. DO NOT step down into low speed when bringing tooling into position. Utilize low speed for setup and recovery only.

ANY ALTERCATIONS TO LIMIT SWITCH ASSEMBLY COMPONENTS WITHOUT MOTION INDEX DRIVES, INC. APPROVAL WILL VOID ALL WARRANTIES.

5.3. Two or Four Station (180° or 90° Reciprocating) Operation

(1) Lever type limit switch (LS1):

Provided for high speed clockwise motor stop. This switch must activate in one direction only, and has an adjustable switch actuation cam.

(1) Lever type limit switch (LS2):

Provided for high speed counter-clockwise motor stop. This switch must activate in one direction only, and has an adjustable switch actuation cam.

(1) Plunger type limit switch (LS3):

Provided for jog speed motor stop as well as dwell configuration. This is a non-adjustable switch, with a non-adjustable switch actuation cam pinned to the index drive limit switch shaft.

5.4. Visual Pin Indicator

There are many different forms of dwell indicators on indexers. These forms include a machined line in the input shaft of the indexer, and indicator pin screwed into the input shaft, or an indicator pointer plate screwed into the input shaft. Whichever method of indication, it is imperative that the indexer stop in the position, which is indicated by the indicator tag on the unit. The in position location on standard rotary index drives is at 12:00, or straight up (for horizontal mounting).

The lever type limit switch actuation cam has a screw which can be loosened to enable the actuation cam to be manually rotated until the resulting visual pin indicator stops at the center line of the red home position (zero of the cam) marking plate, thus reflecting the internal center of cam dwell of the Motion index drive. (See figure at side for example)

5.5. Limit Switch Adjustments*

Clockwise Rotation of Tooling:

When tooling is rotating clockwise the output shaft is rotating counter clockwise. If the indicator pin is stopping to the left of "zero" this means that the cam that is triggering the switch for forward stop is triggering it too late, it is over rotating. Loosen this cam and rotate it in the CCW direction so it triggers the switch sooner. If the indicator pin is stopping to the right of "zero" this means that it is under traveling. Loosen the forward stop cam and rotate it CW so that it triggers the switch later.

Counterclockwise Rotation of Tooling:

When tooling is rotating counterclockwise the output shaft is rotating clockwise. If the indicator pin is stopping to the left of "zero" this means that the cam that is triggering the switch for forward stop is triggering too soon, it is under rotating/ loosen this cam and rotate it in the CCW direction so it triggers the switch later. If the indicator pin is stopping to the right of "zero" this means that it is over traveling. Loosen the forward stop cam and rotate it CW so that it triggers the switch sooner.

*For standard models only

Rotation of tooling and shaft maybe different if indexer has been custom made for your application

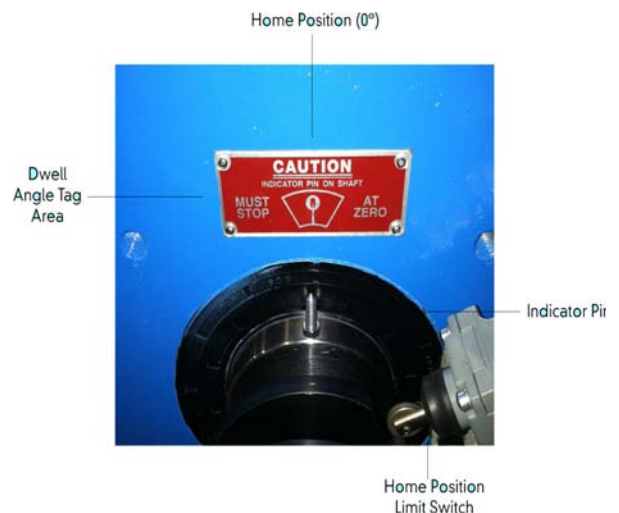
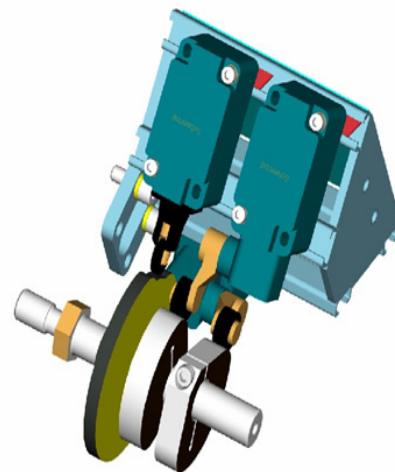

6. Operation of Fixed Index Drive with VFD (Variable Frequency Drive)

The operation of an index drive can benefit greatly from running on a VFD/Amplifier. However, the following MUST be followed to ensure proper operation and to prevent immediate and irreversible damage to the index drive.

6.1. Normal Operation

Normal Operation is defined as starting and stopping the index drive from dwell to dwell, or from position to position. Normal operation is the primary operation the index drive will function. In Normal Operation, the index drive must run at a constant speed during the entire cycle. This means once the set frequency is reached (i.e. 45HZ, 60HZ, etc), this frequency should be maintained until the end of the cycle. THE FREQUENCY SHOULD NOT DECEL OR JUMP FROM A HIGHER TO LOWER FREQUENCY prior to reaching a position! Doing so WILL damage the index drive. The index drive should run the constant frequency and the decel should be as short as possible (i.e. 0.1 sec). Extended deceleration times (i.e. 1.0 sec, 1.5 sec, etc.) and jumping motor speed (i.e. 50 to 25 HZ) in normal operation cause the motor to try to decelerate the internal cam down at a different rate than the mechanics of the cam allow. This causes extreme vibration and infinite loads on the cam followers. The cam in the index drive will smoothly stop the rotating mass upon reaching dwell, and the motor will then only be required to stop itself.

Normal Operation Parameters:

Acceleration: 0.1 seconds

Deceleration: 0.1 seconds

Frequency: Based on customer application.

EXCEEDING MOTION INDEX DRIVES RECOMMENDED FREQUENCY AND/OR JUMPING FREQUENCIES DURING NOR-MAL OPERATION WILL IMMEDIATELY VOID WARRANTY.

6.2. Jogging Operation

Jogging is defined as rotating the index drive in a slow, manual mode. This is typically done in the initial setup. For jogging, it is recommended to run the index drive at a much slower frequency (i.e. 20HZ), and accel/decel rates are suggested at 0.5 seconds. During jogging, it is required to bring the index drive to a dwell period or position pri-or to running the index drive in Normal Operation.

6.3. E-Stop Operation/Stopping out of Position

E-stop conditions are defined as the immediate stop of the index drive due to one of many factors, including operator light screen or safety mat being activated, robot errors, or e-stop buttons being activated and involve the requirement of the index drive to stop out of position. Operating the index drive properly with a VFD/Amplifier during e-stops, or stopping out of position is critical to ensuring the indexers operation.

During the e-stop, if dynamic braking is being utilized in the VFD/Amplifier, ensure that the dynamic braking time is not any less than 0.6 seconds. Longer braking time is acceptable. During e-stop, it is critical to ensure that the dynamic brake is not driving through the brake or the motor if the motor is equipped with one. The brake circuit should be applied after the dynamic braking time.

To restart from an e-stop or out of position stop, it is suggested to accelerate the motor to a slower frequency, (i.e. 20-25Hz), until the next dwell position is reached. It is also recommended when starting from out of position to have an acceleration time of 0.5-1.0 seconds. Once the index table has reached dwell or is in position, normal operation procedures can then be reapplied.

E-stop/Stopping Out of Position Parameters:

Accel after e-stop: 0.5-1.0 seconds

Decel after e-stop: 0.5-1.0 seconds

Frequency after e-stop: 20-25 HZ.

Dynamic Brake Time/Decel Time during e-stop: >0.6 seconds



Warning: It is imperative that the controls individuals understand this operation prior to commissioning an index drive. For any questions, please contact Motion Index Drives, Inc. prior to commissioning index drive to prevent irreversible damage to the index drive from improper operation. Improper operation of the index drive with variable frequency drive will immediately void warranty!

7. Cycle times

A complete cycle of the rotary index table is defined as the indexing of the drive flange from one dwell position to the next. The cycle time consists of the index time and dwell time together. The index time corresponds to the index angle of the cam and the dwell time corresponds to the angle without the cam gradient.

8. Speeds

The maximum speed of the drive flange, or the shortest index time of the rotary index table, depends on the re-sulting built-up load (mass moment of inertia).

Example: Load Table RT100

		Column #												
Speed Step		1	2	3	4	5	6	7	8	9	10	11	12	13
n	J			0.38	0.57	0.76	1.07	1.52	1.87	2.13	2.37	2.9	3.32	4.27
	t			0.22	0.56	1.1	2,4	5.4	8.6	11.7	14.9	23.7	32	57
2	J		0.25	0.36	0.54	0.71	1	1,43	1.75	2	2.22	2.72	3.11	4
	t		0.13	0.38	0.97	1.9	4,1	9.3	14.8	20.2	25,7	41	56	99
3	J		0.22	0.32	0.48	0.64	0.9	1.29	1.58	1.8	2	2.45	2.8	3.6
	t		0.26	0.47	1.25	2.4	5.3	11.4	18	24.8	32.5	50	69	122
4	J		0.22	0.32	0.48	0.64	0.9	1.29	1.58	1.8	2	2.45	2.8	3.6
	t		0.32	0.66	1.7	3.3	7	16	26	35	44	71	97	173
5	J	0.19	0.22	0.32	0.48	0.64	0.9	1.29	1.58	1.8	2	2.45	2.8	3.6
	t	0.39	0.48	0.9	2.25	4.3	9,3	21	34	46	58	93	127	226
6	J	0.19	0.22	0.32	0.48	0.64	0,9	1.29	1.58	1.8	2	2.45	2.8	3.6
	t	0.52	0.64	1.3	3.3	6.4	13.8	31.5	50	68	87	138	183	297
8	J	0.19	0.22	0.32	0.48	0.64	0.9	1.29	1.58	1.8	2	2.45	2.8	
	t	0.65	0.82	1.72	4.4	8.6	18.5	42	67	92	115	171	225	
10	J			0.32	0.48	0.64	0.9	1.29	1.58	1.8	2	2.45	2.8	
	t			2.16	5.5	10.6	23	52	83	113	145	210	276	
12	J			0.16	0.24	0.32	0.45	0.64	0.79	0.9	1	1.23	1.4	
	t			0.95	2.4	4.6	9	19	29	38	46	70	91	
16	J			0.16	0.24	0.32	0.45	0.64	0.79	0.9	1	1.23	1.4	
	t			1.28	3.2	6	11.8	24	36	47	58	88	115	
20	J			0.16	0.24	0.32	0.45	0.64	0.79	0.9	1	1.23	1.4	
	t			1.6	4.1	7	14	29	43	57	70	105	138	
24	J			0.16	0.24	0.32	0.45	0.64	0.79	0.9	1	1.23	1.4	
	t			1.7	4.5	8.6	16	32	48	62	79	119	155	
30	J			0.16	0.24	0.32	0.45	0.64	0.79	0.9	1	1.23	1.4	
	t			2.46	4.32	8.6	17	29	38	47	63	83		
36	J			0.16	0.21	0.3	0.43	0.53	0.6	0.67	0.82	0.93		
	t			2.46	4.32	8.6	17	29	38	47	63	83		

J = Inertia
t = Index Time

The shortest possible index time with any existing mass moment of inertia guarantees a service life of at least 30,000 hours of pure fixed-cycle operation. This means that a rotary index table with a 0.5s index time, one would calculate 120 cycles for a minute of operating time (regardless of the interval time specified by the use). If a longer index time than that specified in the index time table is chosen than the service life of the rotary index table is dramatically extended. Doubling of the index time extends the service life by a factor of 200 to 500. The speed can be altered either in fixed stages or continuously.

Fixed Stages:

There are 4,6, or 8 pole motors and gear reducers with various reduction gear ratios available. The combination of the two gives us a sensitive gradation of the index times.



9. Maintenance

Maintenance includes inspections, servicing and overhauling. Maintenance work may only be undertaken by an experienced specialists. Before working on the rotary index table and related tooling, switch the drive off electrically and make sure it cannot restart by itself. Proper lockout procedures must be followed.



9.1. Maintenance

The index tables and the gear reducer on the drive do not need to be regularly filled with oil for the duration of their life in normal environments and applications. If for any reason oil is drained, the filling amounts can be found in the operating manual for the drive. The type of oil to be used is Mobilgear XP460.

Index table must be greased while running. This can be done by running lube lines to the fence or using a manual greasing system.



Every month please lubricate using the bearing grease fittings on all TMF Series and models RT400 and larger. RT100 to TT315 index drives are maintenance free (do not require greasing). Please lubricate bearing with EP2 grease. (See lubrication chart)

Do not mix mineral lubricants with synthetic lubricants.

9.2. Inspection

The intervals specified must be adjusted to suit the conditions.



Switch the drive off electrically and make sure it cannot restart by itself.

Every six months visually inspect for damage. Remove any deposit of dust (especially on the ventilation grille of the motor) and examine the electrical cables for damage.

Every six months check the rotary index table for play in the dwell position

9.3. Overhauling

If the rotary index table is damaged, please contact Motion Index Drives, Inc. Only repairs performed by an MID certified technician ensures proper functionality and optimal performance. Any unauthorized opening of the casing will void the warranty.

The rotary index table must be checked for play. If there is any play in one or more stations, the cam rollers have to be replaced.



All cam followers may have to be replaced. Check whether the mounting holes for the cam followers in the output dial flange are still round and true to size. If holes are out of round the output dial flange will have to be replaced.



MOTION INDEX DRIVES

10. Spare Parts and Wear

Motion index Drives, Inc. rotary index tables are maintenance free when commissioned correctly, and loading and operating environment are clearly defined by the customer.

MID. The cam followers do not cause any wear and tear on the hardened cam tracks; all roller bearings are oversized and run through an oil bath. For reasons of safety, only replacement parts which are of the same quality as the original parts may be used. When ordering, please give the following data:

- Model and shop order number, see ID plate
- Name
- Quantity

Wear parts are marked (x). Please order replacement parts set. The quantity or amount of the cam followers and lubricants depend on the model and design of the rotary index table.

Number	Quantity	Name
01	1	Housing
02	1	Input Shaft
05 (x)	2	Shaft Seal
06 (x)	2	Locknut Input Shaft
07 (x)	2	Tapered Roller Bearing
08 (x)	1	Locknut Cam
09	1	Barrel Cam
10	1	Central Column
12 (x)	1	O-Ring
13	1	Output Flange / Drive Flange
14 (x)	1	Inner Top Dial Seal
15 (x)	n*	Cam Follower
16 (x)	1	Outer Top Dial Seal
18 (x)	1	Four Point Contact Bearing
19 (x)	1	Adjustment Ring for Four Point Contact Bearing
20 (x)	1	O-Ring
21 (x)	1	O-Ring
22 (x)	1	Center Ring for Four Point Contact Bearing
23 (x)	1	Shaft Seal
26	1	Housing Cover
	n*	Depending on Number of Indexes

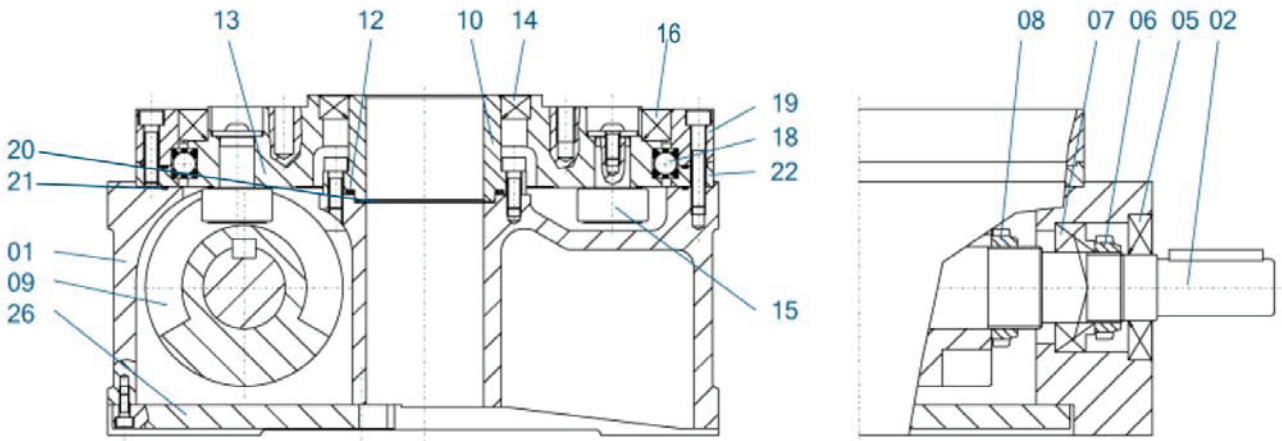

RT Series Section Shown

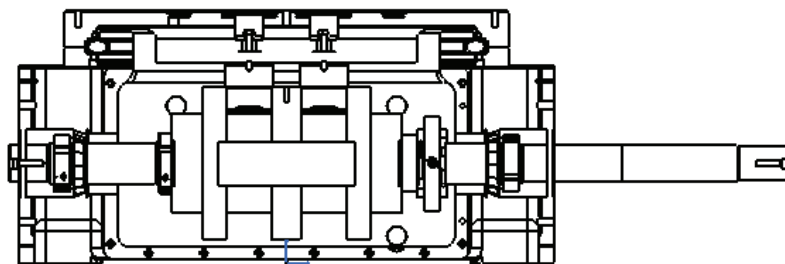

TMF Series Section shown.
Cam Followers extractable through top dial



11. Sew Euro-Drive Common Motor & Brake Rectifier Connections



Warning: Please make sure motor supplied with the Motion Index Table is SEW. If not, please refer to motor instructions located in motor junction box for wiring schematic for your particular motor brand.

BUR Brake Control (If Applicable)

The BUR is not a rectifier. Rather, it is a package that consists of the BGE rectifier and the UR relay for applications that require both fast release and rapid reaction.

BUR = UR relay + BGE rectifier

The UR relay mounts at the terminal box, but receives its voltage source from the control panel. It is specially suited for two-speed motors or AC induction motors that operate from an inverter, since both applications require a separate voltage supply for the brake.

Bur is recommended when an inverter or a two-speed motor is used in an application requiring any of the following:

- Frequent cycling
- Minimal stopping distance with the highest accuracy

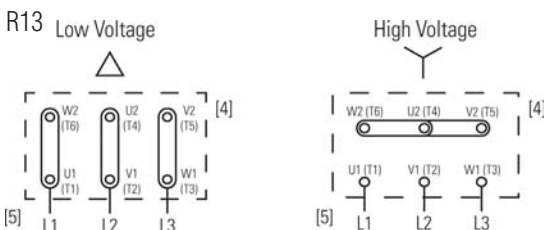
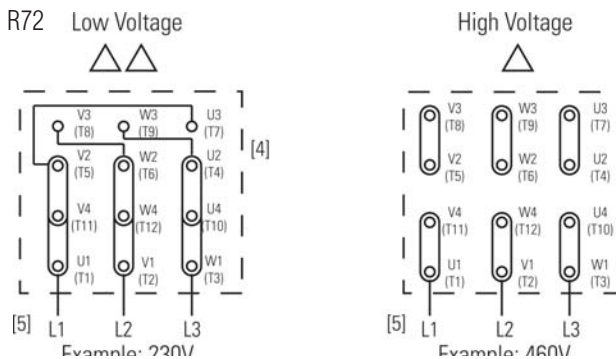
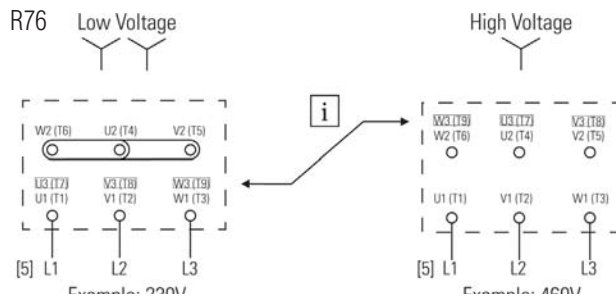

Motor Connection Diagrams (Above)

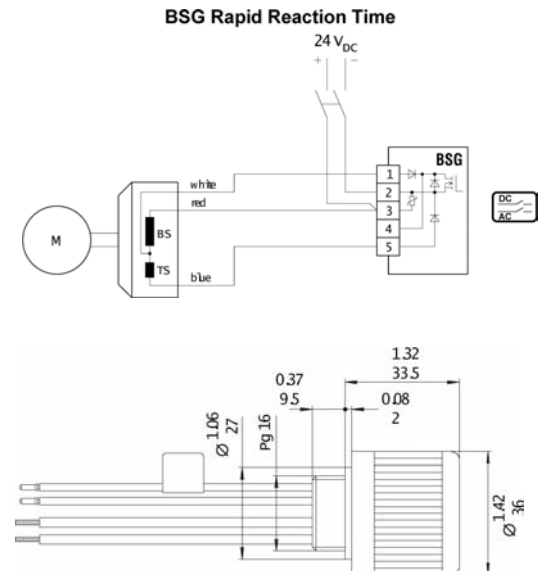
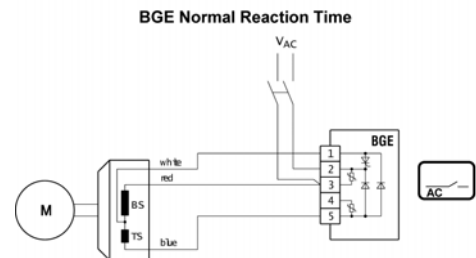
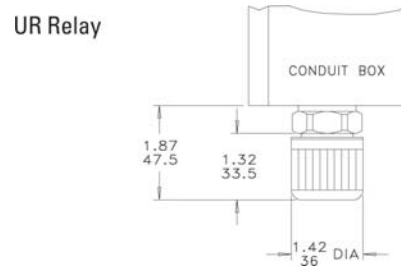
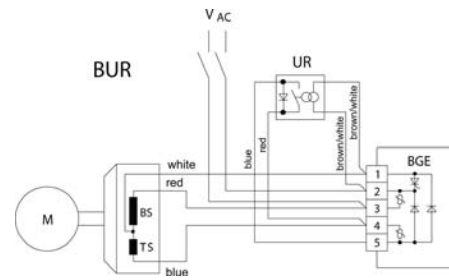

Brake Connection Diagrams (Above)