

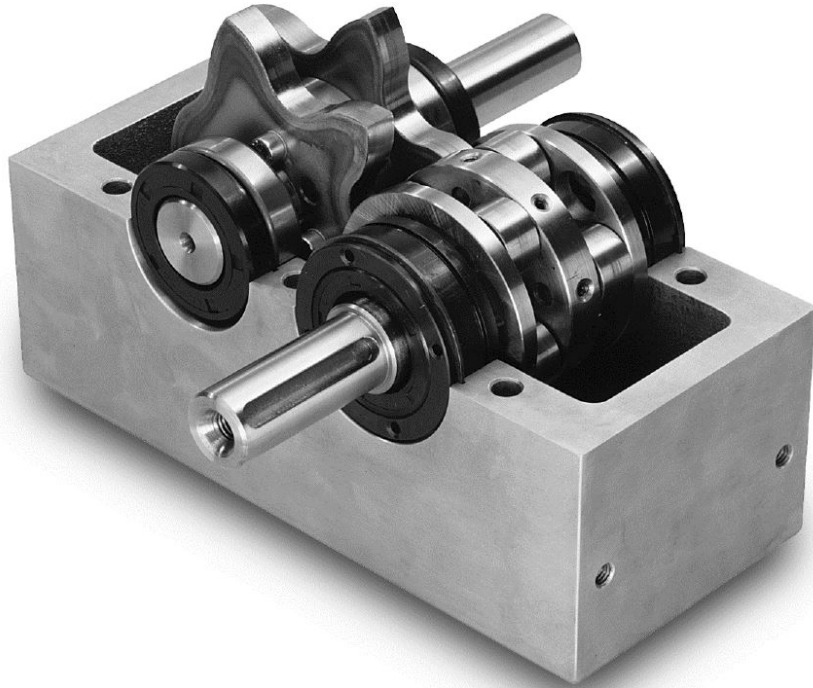

# MOTION

## INDEX DRIVES



# XP - TP - SP Parallel Indexer

Operating Instructions



## Table of contents

<b>1</b>	<b>About these Operating Instructions</b> .....	<b>3</b>
<b>1.2</b>	<b>Continuative documents</b> .....	<b>5</b>
1.3	Excerpt of Declaration of Incorporation .....	6
<b>2</b>	<b>Safety information</b> .....	<b>7</b>
<b>2.1</b>	<b>Explanation of the symbols used</b> .....	<b>7</b>
<b>2.2</b>	<b>Intended use</b> .....	<b>9</b>
<b>2.3</b>	<b>Foreseeable misuse</b> .....	<b>9</b>
2.4	Directives, statutory provisions and standards.....	9
<b>2.5</b>	<b>Technical condition of the machine</b> .....	<b>9</b>
<b>2.6</b>	<b>General hazards</b> .....	<b>10</b>
2.7	Responsibility of the operator .....	11
2.8	Staff qualification .....	12
<b>3</b>	<b>Product description</b> .....	<b>13</b>
3.1	Construction of Parallel-Indexer .....	13
3.2	Construction Parallel-Indexer type SP .....	14
3.3	Function .....	14
3.4	Nameplate.....	16
3.5	Operating modes .....	17
3.6	Cycle time .....	18
3.7	Technical Data Parallel-Indexer.....	19
3.8	Ambient conditions .....	35
<b>4</b>	<b>Transport</b> .....	<b>37</b>
4.1	Safety information .....	37
4.2	Transport inspection .....	37
4.3	Packaging, handling, unpacking .....	37
<b>5</b>	<b>Mechanical installation</b> .....	<b>40</b>
5.1	Installation orientation.....	40
5.2	Installation and commissioning.....	41
<b>6</b>	<b>Service and maintenance</b> .....	<b>42</b>
6.1	Safety information in respect of maintenance .....	42
6.2	Maintenance tasks.....	43
6.3	Checking the oil level.....	43
6.4	Lubrication .....	44
6.5	Replacing cam follower .....	46
<b>7</b>	<b>Troubleshooting</b> .....	<b>54</b>
7.1	Safety information .....	54
<b>8</b>	<b>Disassembly</b> .....	<b>55</b>
<b>9</b>	<b>Disposal</b> .....	<b>55</b>
<b>10</b>	<b>Spare part and wear part</b> .....	<b>56</b>
10.1	Spare part and wear part type XP - TP – SP .....	56
<b>11</b>	<b>Annex</b> .....	<b>61</b>
11.1	Safety data sheets .....	61



## 1 About these Operating Instructions

These Operating Instructions describe the partly completed machinery Parallel-Indexer. The partly completed machinery Parallel-Indexer is referred to below as 'the machine'.

### **Purpose of these Operating Instructions**

The Operating Instructions are intended to help you to:

- work efficiently
- ensure quality
- find information quickly
- avoid danger

### **Table of contents**

The Operating Instructions have a table of contents at the front. This gives you an overview of all the sections in the document.

### **Headings and page numbers**

The chapters are numbered sequentially. The sections within each chapter are numbered sequentially.

### **Safety information**

Any safety information is placed before the descriptions of actions that may pose a risk. You will find a detailed description of the safety information in the chapter entitled Safety.

### **Text, symbols, figures**

Instructions for performing various activities and other information are presented in small, discrete sections.

The information is presented using a combination of text, symbols and figures.

Instructions for performing action are described in the appropriate sequence and numbered accordingly.

### **Instructions for action**

For the sake of clarity the instructions for action have been broken down into individual steps:

- ▶ Introductory text...
- Instruction result

### **Lists**

Any lists which do not include individual operating steps are indicated as follows:

- Lists...
- Sub-items in lists

### **Figures**

Figures, dimensions and technical data presented in these Operating Instructions may be Subject to change.

### **Cross-references**

Cross-references point you to additional descriptions within the Operating Instructions. (Chapter number/page number).

### **Third-party components**

Refer to the Operating Instructions of the relevant manufacturers for information on operation and maintenance of third-party components fitted in the system.

### **Additional documentation**

To complement the information in these Operating Instructions, please read the following regulations and directives:

- safety regulations and accident prevention regulations
- instruction sheets, instruction booklets
- work instructions provided by the statutory accident insurance provider
- generally accepted occupational health regulations



**Manufacturer**

Motion Index Drives  
1204 East Maple Rd  
Troy MI 48083

Phone: 248-743-9999  
Fax: 248-743-0749  
E-mail: [info@mid.us.com](mailto:info@mid.us.com)  
Website: [www.motionindexdrives.com](http://www.motionindexdrives.com)

**Technical information**

The technical information, figures and data contained in these Operating Instructions are correct at the time of printing.

Our products undergo continuous further develop.

We therefore reserve the right to make any changes and improvements that we deem appropriate.

However, this does not, imply any obligation to apply such changes retrospectively to equipment already supplied.

**1.1.1 Published by**

Motion Index Drives  
1204 East Maple Rd  
Troy MI 48083

Reproduction of these Operating Instructions or extracts thereof in the form of a reprint or photocopy, on electronic storage media or by any other means is not permitted except with our written consent.

All rights reserved.

**Document revision**

Version	Date	Comment	Name
Version 1.0.4	02.05.2018	Initial publication	



## 1.2 Continuative documents

Read the following documents according to the provided components before you use these machine with Operating instruction.

Designation	Manufacturer	Version / Revision / Date	Number
Assembly and Operating Instructions Gear unit series R..7, F..7, K..7, K..9, S..7, SPIROPLAN@ W	SEW	Edition 05/2015; Version 14; ID 117093590918839435	21932786
Operating Instructions AC Motors	SEW	Version 10; ID 81064793821256459	21927189
Operating Instructions CMP40 – CMP112, CMPZ71 – CMPZ100	SEW	Edition 07/2015; Version 8; ID 63050397671999115	21923582
Operating instructions inductive Sensors	Balluff		



1.3 Excerpt of Declaration of Incorporation

Translation of Declaration of Incorporation  
in accordance with the EC Machinery Directive 2006/42/EC, Annex II (1) (B) for partly  
completed machinery



MOTION  
INDEX DRIVES

**Manufacturer**  
Motion Index Drives  
1204 East Maple Rd  
Troy MI 48083

**A person established within the community who is authorized to  
compile the relevant technical documents:**  
Motion Index Drives  
1204 East Maple Rd  
Troy MI 48083

Description and identification of the partly completed machinery

Product	Parallel-Indexer
Type	XP - TP – SP
Code	, - - - -
Serial number	R R -
Project number	PRJ-2017-01-19-0001
Order	wechselnd
Function	Parts are mounted on the output shaft of the Parallel-Indexer. The Parallel-Indexer has a fixed division (for an exact design see data sheet). The Parallel-Indexer is inside a safety enclosure or is installed in another work equipment. The safety enclosure or assembly are realized by the integrator. This also applies to the electrical connection and control.

**A declaration is made that the following basic requirements of the Machinery Directive 2006/42/EC are met:**

1.12, 1.1.3, 1.1.5, 1.1.6, 1.2.3, 1.2.5, 1.3., 1.3.1, 1.3.2, 1.3.3, 1.3.4, 1.3.7, 1.4, 1.5.1, 1.5.4, 1.6.1, 1.6.3, 1.6.4, 1.7.1.1, 1.7.1.2

**A further declaration is made that the special technical documents were created in accordance with Appendix VII Part B.**

**It is expressly stated that the partly completed machinery complies with all relevant provisions of the following EC directives or regulations:**

2006/42/EG Directive 2006/42/EC of the European Parliament and of the Council of 17 May 2006 on machinery, and amending Directive 95/16/EC (recast) (1)

**Reference to the harmonized standards applied in compliance with Article 7(2):**

EN ISO 12100:2010-11 Safety of machinery - basic concepts - risk assessment and risk mitigation (ISO 12100:2010)

The manufacturer or authorised person undertake to transmit, in response to a reasoned request by the national authorities, relevant information on the partly completed machinery. This transmission shall be made in:

Data form

Intellectual property rights remain unaffected by this!

**Important note! The partly completed machinery must not be put into service until the final machinery into which it is to be incorporated has been declared in conformity with the provisions of this Directive, where appropriate.**

Place, date

Signature  
Benedict Talan  
Managing Director



## 2 Safety information

### General information

This document contains important information on the safe use of the machine. This information is intended to ensure personal safety and prevent damage to the machine. The information is intended for the operator and for properly trained, qualified and instructed staff responsible for operating and servicing the machine.

Additional task-specific safety information is included in the relevant sections on the different phases during the service life of the system.

### 2.1 Explanation of the symbols used

#### 2.1.1 Warnings

	<b>DANGER</b>
	<p><b>DANGER!</b> This combination of symbol and alert word indicates an inherently dangerous situation which can be fatal or cause serious injury if it is not avoided.</p>
	<b>WARNING</b>
	<p><b>WARNING!</b> This combination of symbol and alert word indicates a potentially dangerous situation which can be fatal or cause serious injury if it is not avoided.</p>
	<b>CAUTION</b>
	<p><b>CAUTION!</b> This combination of symbol and alert word indicates a potentially dangerous situation which can cause minor injury.</p>
	<b>NOTICE</b>
	<p><b>NOTICE!</b> This combination of symbol and alert word indicates a potentially dangerous situation which can cause damage to property or harm the environment if it is not avoided.</p>

#### 2.1.2 Prohibition signs

	IT IS NOT PERMITTED TO CARRY METAL PARTS OR WATCHES!
	PROHIBITION FOR PERSONS WITH PACEMAKERS!
	PROHIBITION FOR PERSONS WITH METALL IMPLANTS!
	SWITCHING PROHIBITED!



2.1.3 Warning signs



WARNING OF HAZARDOUS ELECTRICAL VOLTAGE!



WARNING DANGER DUE TO HOT SURFACE!



WARNING MAGNETIC FIELD!



WARNING CRUSHING OF HANDS!



WARNING VOR COUNTERROTATING ROLLERS!

2.1.4 MANDATORY SIGNS



REFER TO INSTRUCTION MANUAL/BOOKLET!

This symbol signifies that the instruction manual/booklet of the component supplier must be read.



WEAR HEAD PROTECTION!

This symbol signifies that head protection must be worn.



WEAR EYE PROTECTION!

This symbol signifies that eye protection must be worn.



WEAR SAFETY FOOTWEAR!

This symbol signifies that safety footwear must be worn.



WEAR PROTECTIVE GLOVES!

This symbol signifies that protective gloves must be worn.





## 2.2 Intended use

The machine is intended for installation in a surrounding construction, thus integrating it to form part of an overall system. The machine is controlled by the overall system. The functions of the protective equipment are also connected to the machine via the controller. The machine may only be operated as part of a CE-compliant system. Das Parallel-Indexer dient zum positionsgenauen Transport von Werkstückträgern von einer Bearbeitungsstation zur anderen in einer Gesamtanlage.

**Any use that deviates from the intended use is regarded as inappropriate use.**

**This includes:**

- any use outside the permitted operating limits
- any use in conjunction with foodstuffs
- any use in conjunction with aggressive materials (such as acids)
- transporting the system using the designated lifting points or eye bolts

**The manufacturer shall not be liable for any damage resulting from such use. Intended use also includes observance of all the information in these instructions.**

## 2.3 Foreseeable misuse

Any use beyond or other than the intended use is regarded as misuse.

### 2.3.1 Guarantee conditions

Changes to the structure of the materials used in the machine, e.g. the drilling of additional holes, can result in damage to the components. This is not regarded as intended use and may lead to loss of warranty or liability claims as a consequence.

## 2.4 Directives, statutory provisions and standards

The following statutory provisions and standards were applied:

Machine Directive	2006/42/EG, Annex I
Low Voltage Directive	2014/35/EU
EMC Directive	2014/30/EU
Safety of machinery - basic concepts - risk assessment and risk mitigation	DIN EN ISO 12100

## 2.5 Technical condition of the machine

Do not use the machine if it is not in sound condition technically. If the machine is used when it is not in a sound condition technically, there is a risk of death or injury to staff and a risk of damage to property.

### 2.5.1 Make no changes in the safety provisions

The manufacturer has made safety provisions. No liability will be accepted if the operator of the machine makes any changes in the safety provisions without express permission.



## 2.6 General hazards

This section lists risks associated with the machine that remain even when it is operated according to its intended use.

In order to reduce the risk of personal injury or damage to property, and to avoid potentially dangerous situations, the safety information provided here and in the other sections of these Operating Instructions must be observed.

### 2.6.1 Risk of death by electrocution

#### DANGER



**Risk of death by electrocution!**

**There is an immediate risk of fatal injury due to electric shock if live components are touched.**

**Damage to the insulation or to individual components can cause fatal injury.**

- ▶ Only allow work on the electrical system to be carried out by qualified electrical engineers.
- ▶ In the event of damage to the insulation, immediately shut off the power supply and initiate a repair.
- ▶ Before starting work on active parts of the electrical system or equipment, ensure that it is completely powered down and cannot be switched on again.

### 2.6.2 Risk of injury from moving parts

#### WARNING



**Risk of injury from moving parts!**

**Moving parts can cause serious injury.**

- ▶ Do not reach into moving parts or carry out work on moving parts while the system is in operation.
- ▶ Never open any covers while the system is in operation.



## 2.7 Responsibility of the operator

The machine is to be used commercially according to its intended use. The operator of the machine is therefore subject to statutory occupational health and safety provisions.

In addition to the general safety information contained in this document, any further safety, accident prevention and environmental regulations applicable to the field of application of the machine must also be observed.

**In particular, operators have the following obligations:**

- They must always be fully informed of the most recent occupational safety regulations and perform a risk assessment to identify any additional hazardous locations and places resulting from the specific working conditions at the place of use. They must document any such findings in the form of operating instructions (work instructions, work descriptions, etc.) for use during operation.
- During the entire service life of the machine, they must check whether the operating instructions they have written are compliant with current regulations and make any necessary adjustments.
- They must unambiguously regulate and define who is responsible for carrying out installation, operation, maintenance and cleaning.
- They must ensure that the staff deployed have the necessary qualifications for the work they are instructed to perform.
- They must ensure that all staff who work on the machine have read and understood all the documents relevant for its operation (Operating Instructions, maintenance regulations, safety guidelines).
- They must provide training for the staff at regular intervals and inform them of potential dangers.
- They must bear the responsibility for personal injury and damage to property arising from manipulation of the machine. For this reason, the machine and its safety equipment must be inspected at regular intervals to ensure that they are in sound condition and functioning properly, and the results of this inspection must be suitably documented.
- They must ensure that the machine is always in a sound condition technically.

### 2.7.1 Preventive measures

**It is recommended that the operator take the following preventive measures:**

- Only allow qualified, trained and properly instructed staff to work on the machine.
- Unambiguously define the responsibilities of operating and service personnel.
- Supplement these Operating Instructions with
  - stipulations deriving from national and regional labor and environmental regulations
  - adjust information covering specific operational aspects (workflows, supervisory obligations, reporting obligations, fire alarm equipment, etc.)
- Occasionally check to confirm that the Operating Instructions are being used and that such use is correct, and when necessary repeat the instruction process.
- Ensure that all documentation is permanently available in a readable form and easily accessible at the point of use.
- Observe any periodic checks and inspections that are required (by law) or specified in this document.
- Replace in good time any components indicated in these documents as being crucial for safety.
- Regularly inspect the machine to ensure that the safety equipment operates correctly.
- Make sure that safety information and hazard warnings on the machine and in the working area are always legible.
- Take steps to ensure that the machine is regularly inspected for visible damage and defects.



## 2.8 Staff qualification

The various activities described in these Operating Instructions require different qualifications of the staff entrusted with these duties.

### WARNING



**Danger if staff are insufficiently qualified!**

Persons who are inadequately qualified are unable to assess the risks associated with working on the machine and expose themselves and others to the risk of serious or fatal injury.

- ▶ Ensure that all work is performed only by suitably qualified persons.
- ▶ Keep insufficiently qualified persons at a safe distance from the working area.

### 2.8.1 Qualified staff

For the purposes of these Operating Instructions, qualified staff are understood to be

- Operators who have been specially trained and instructed in working with the machine.
- Installation and service staff who have appropriate expertise in setting up and maintaining the machine and who are familiar with the safety information.
- The qualified staff must have read and understood the contents of the Operating Instructions before the machine is taken into service and must have been informed of the risks associated with working with the machine by the machine operator.
- A knowledge of first aid is required.

### 2.8.2 Competent specialists

Competent specialists are persons whose specialist training and experience have given them sufficient knowledge with respect to using this machine and who are sufficiently familiar with the relevant statutory occupational health regulations, accident prevention regulations, directives, and generally approved technical practice that they are able to assess whether the condition of the machine allows it to be used safely.

### 2.8.3 Auxiliary staff

Work on or in the vicinity of this machine which is not associated with the actual operation of the machine (e.g. cleaning, transport, material provisioning, etc.) can be performed by other persons. Before the machine is taken into service, the qualified staff of the machine operator must instruct such persons with regard to the nature of the work to be performed and the risks associated with working on the machine. Take special care when instructing persons who cannot read or write, and instruct them separately!

### 2.8.4 Servicing, repairing and maintaining the machine

Service, repair and maintenance work on the machine may only be carried out by service engineers of the manufacturer or by qualified staff authorized by Taktomat GmbH. When carrying out such work, always cordon off the working area carefully!

### 2.8.5 Personal protective equipment

Personal protective equipment is intended to protect individuals from safety and health risks at work.

When performing certain tasks on and with the machine, staff must wear personal protective equipment. This is explicitly indicated in the relevant sections of these Operating Instructions.

### WARNING



**Risk of injury from moving parts!**

Exposed jewellery and long hair can be trapped by moving parts and lead to serious injury.

- ▶ Always remove exposed jewellery such as chains, rings and watches before starting work.
- ▶ Protect long hair with a hair net.



### 3 Product description

#### 3.1 Construction of Parallel-Indexer

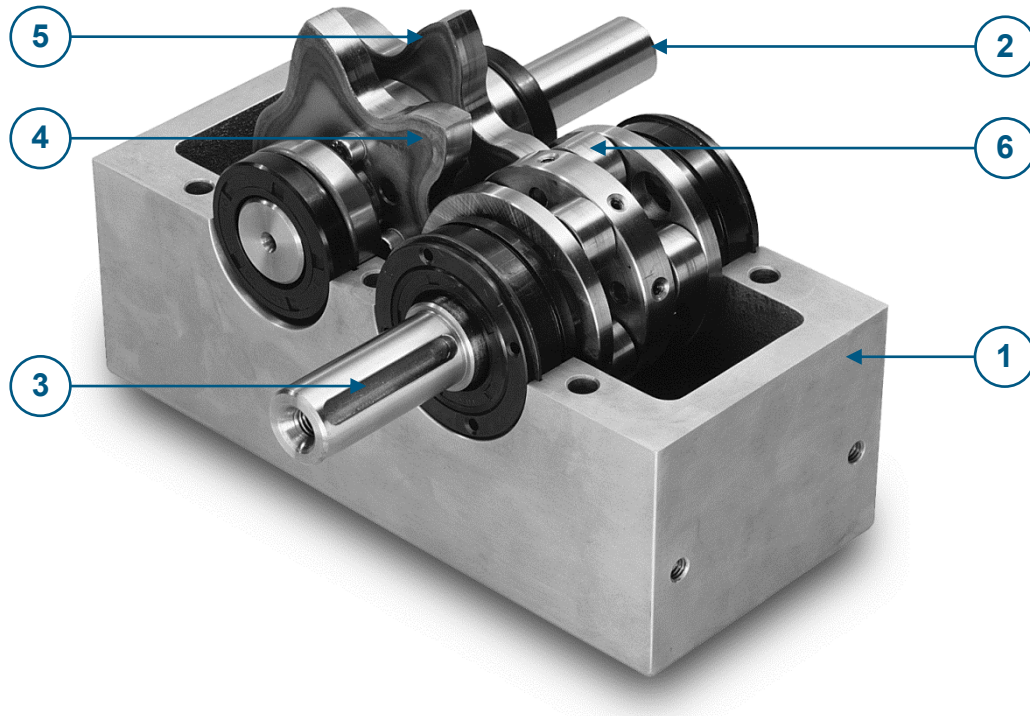

Fig. 1 Construction Parallel-Indexer XP - TP – SP

No.	Designation
1	Housing
2	Input shaft (drive)
3	Output shaft
4	Cam
5	Cam
6	Cam idler
7	
8	
9	
10	
11	
12	



### 3.2 Construction Parallel-Indexer type SP

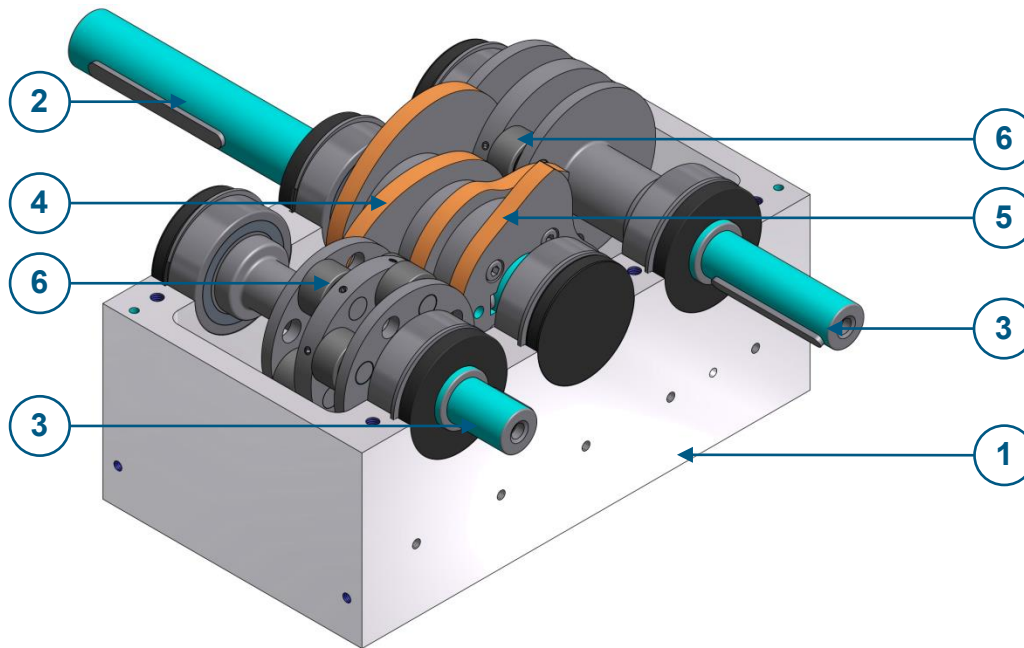

Fig. 2 Construction Parallel-Indexer type SP

No.	Designation	No.	Designation
1	Housing	7	
2	Input shaft (drive)	8	
3	Output shaft	9	
4	Cam set (oscillating movement)	10	
5	Cam set (stepwise movement)	11	
6	Taktomat Cam follower (TKR)	12	

### 3.3 Function

Parallel-Indexers are precision drives which transform a uniform drive movement into stepped or oscillated movements. The use of mathematically defined and standardized curve laws (VDI 2143 Sheet 1) guarantees a jerk and shock free movement.

The structural design of Motion Index Drives Parallel-Indexer produces a positive drive position free of play. An additional interlocking of the drive shaft or of the flanged construction is not required. It could lead to mechanical over-determination and therefore a long-term destruction of the indexing table. The power train either occurs from a AC brake motor via a Worm gear, or from a chain or belt pulley onto the drive shaft of the parallel indexer. That is tightly connected with pulley set and turns the star wheel with the drive shaft. Suitably sized shaft seals seal the parallel indexer to the inside and outside.



Figure 3 Output shaft



Fig. 4 Input shaft with cams

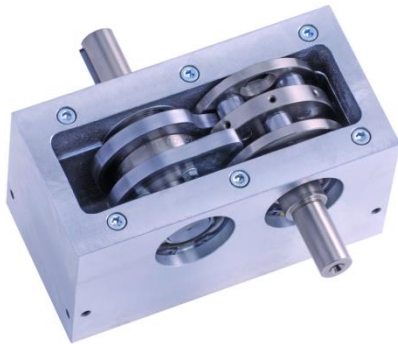

Fig. 5 Parallel-Indexer in step phase

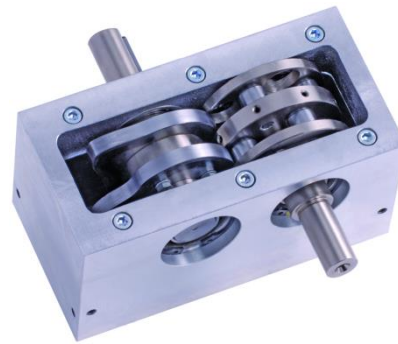

Fig. 6 Parallel-Indexer in dwell phase



### 3.4 Nameplate

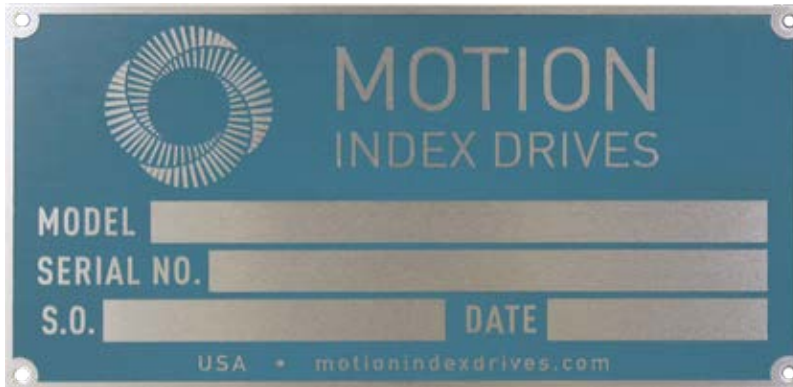

Figure. 7 Example of a nameplate

There is a nameplate attached to the machine:

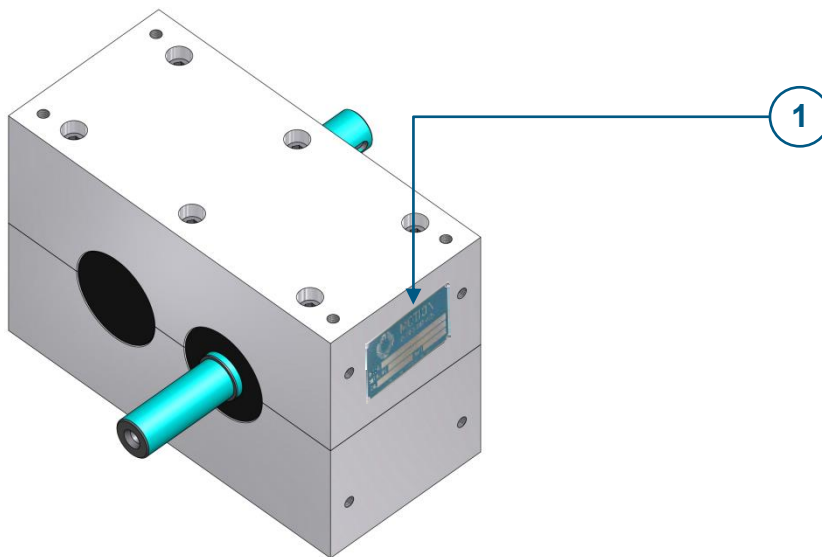

Fig. 8 Position nameplate





### 3.5 Operating modes

The machine has the following operating modes:

- Normal operational
  - Intermittent operation
  - Continuous operation
  - Reversing operation (Oscilating operation)
- Inching mode
- Emergency-Stop

#### NOTICE



**Damage arising from operation without an appropriate machine controller!  
Improper control of the machine can cause serious material damage.**

- ▶ Do not operate in inching mode without an appropriate universal machine controller.
- ▶ Use an appropriate universal machine controller.

#### 3.5.1 Normal operation

Normal operation is regarded as the movement of the drive flange in a direction from one dwell position to the next. The rotational direction of the drive flange is determined by the rotational direction of the drive. With a three-phase motor this can easily be reversed by swapping two phases of the supply voltage.

##### 3.5.1.1 Intermittent operation

The drive shaft stops in the dwell phase. The step time is fixed. The dwell period is variable. This mode of operation is used in plants with much longer processing times than times and is the most common mode of operation.

##### 3.5.1.2 Continuous operation

The machine runs continuously without the motor stopping. Step and dwell times are fixed and are run through continuously. The drive motor has only one rotational direction. This mode of operation is frequently used in fast-running plants with short processing times. The machine is mechanically synchronized to the rest of the plant by the free drive shaft. The ratio of dwell to step time can be adjusted within certain limits by TAKTOMAT when producing the cam.

#### 3.5.2 Reversing operation (reciprocating operation)

The drive of the machine is always reversed in the dwell phase. In this mode of operation, the drive flange shuttles back and forth between two positions. With rotation angles of less than 90° on the drive flange, the cam can be constructed in such a way that continuous reversing operation is possible without the direction of the drive being reversed.

#### 3.5.3 Inching mode

In inching operation, the drive flange moves in small increments between two dwell positions. The cylinder cam / switch cam cannot gently accelerate and decelerate the accumulated load. This puts the hardware under stress, since any acceleration that occurs during the inching operation exceeds that of normal operation many times over. No inching operation is permitted if there are no suitable machine controls that allow gentle acceleration and braking of the load outside the dwell phase.

#### 3.5.4 Emergency-Stop

Emergency stop is comparable with the stopping in inching operation. Here, too, the stopping and re-starting of the accumulated load occurs outside the dwell phase. Frequent emergency-stop situations should be avoided.

### 3.6 Cycle time

A complete cycle of the Parallel-Indexer is defined as the indexing of the drive flange from one dwell position to the next. The cycle time consists of the step time and dwell time together. The step time corresponds to the step angle of the cam and the dwell time corresponds to the angle without the cam gradient.

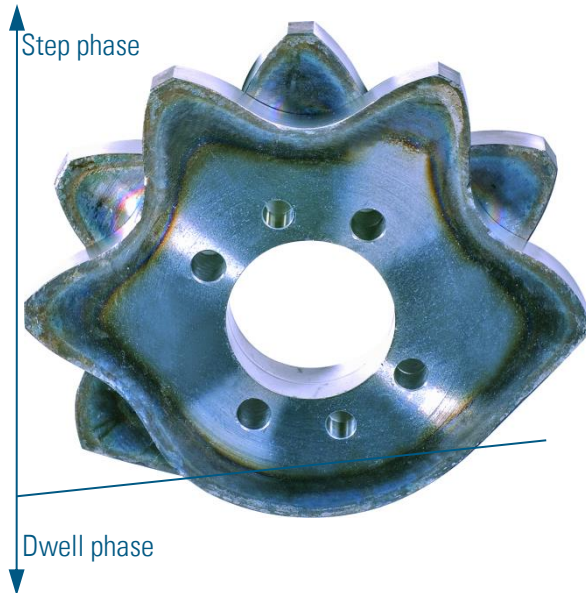

Fig. 9 Cam set dwell – and switch phase

**Example: XP105-04-270:**

This is a parallel indexer with a 105mm center distance base, a stopping number of 4 (4x90° output shaft rotation), a cam switching angle of 270° and a dwell angle of 90°. At an input speed of 60 rpm, the output shaft would complete 60 pulses per minute. The cycle time of the output shaft herein is 0.75s. The dwell period is 0.25s.

### 3.7 Technical Data Parallel-Indexer

#### 3.7.1 Parallel-Indexer type XP 030

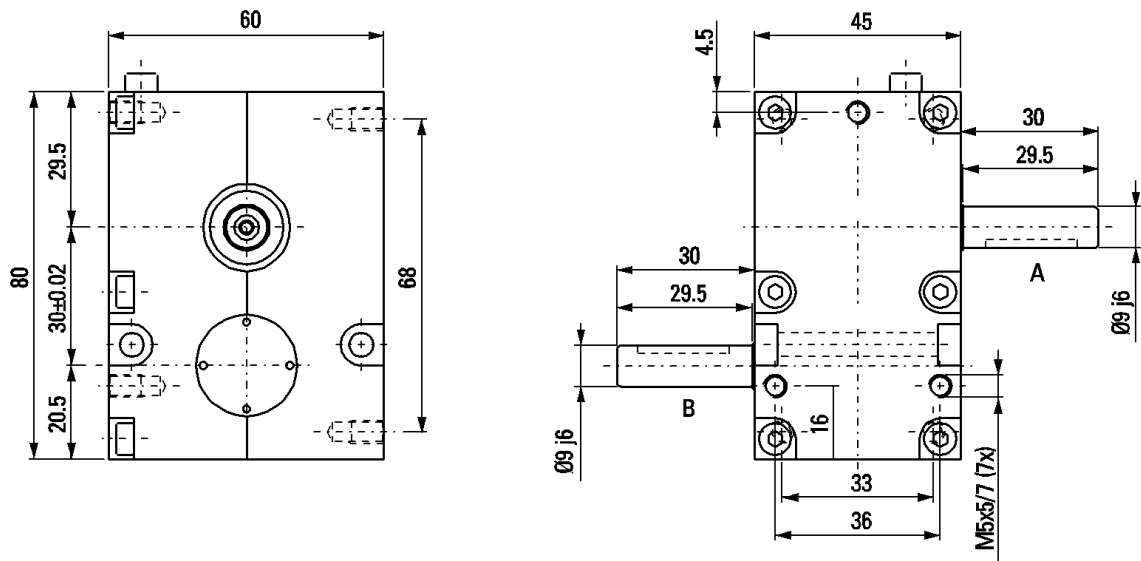

Fig. 10 Dimensional drawing Parallel-Indexer type XP 030

#### Main dimensions

Centre distance [mm]	30
Length x width x height [mm]	80 x 45 x 60
Parallel-Indexer without drive ca. [kg]	0.7
Standard internal transmission ratio	1, 2, 3, 4, 5, 6, 8
Direction	cw, ccw, oscillating
Installation orientation	universal

#### Max. strain on input shaft

Dynamic load rating [kN]	1.38
Static load rating [kN]	0.58

#### Max. strain on output shaft

Dynamic load rating [kN]	1.38
Static load rating [kN]	0.58







### 3.7.4 Parallel-Indexer type XP 065

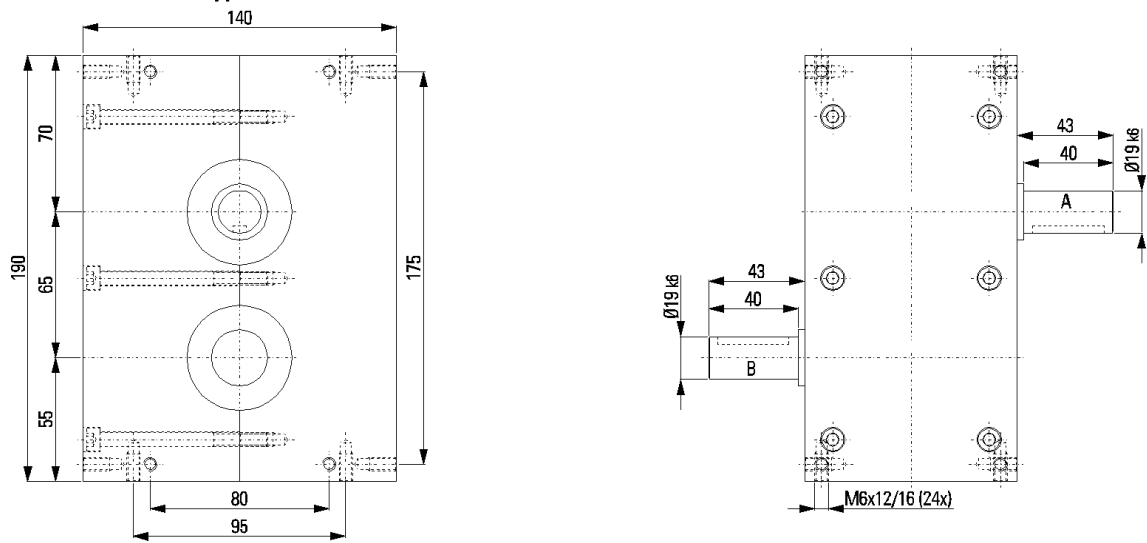

Fig. 13 Dimensional drawing XP 065

#### Main dimensions

Centre distance [mm]	65
Length x width x height [mm]	190 x 95 x 140
Parallel-Indexer without drive ca. [kg]	8
Standard internal transmission ratio	1,2, 3, 4, 5, 6, 8, 10, 12
Direction	cw, ccw, oscillating
Installation orientation	universal

#### Max. strain on input shaft

Dynamic load rating [kN]	11.9
Static load rating [kN]	6.55

#### Max. strain on output shaft

Dynamic load rating [kN]	11.9
Static load rating [kN]	6.55





**3.7.6 Parallel-Indexer type XP 105**

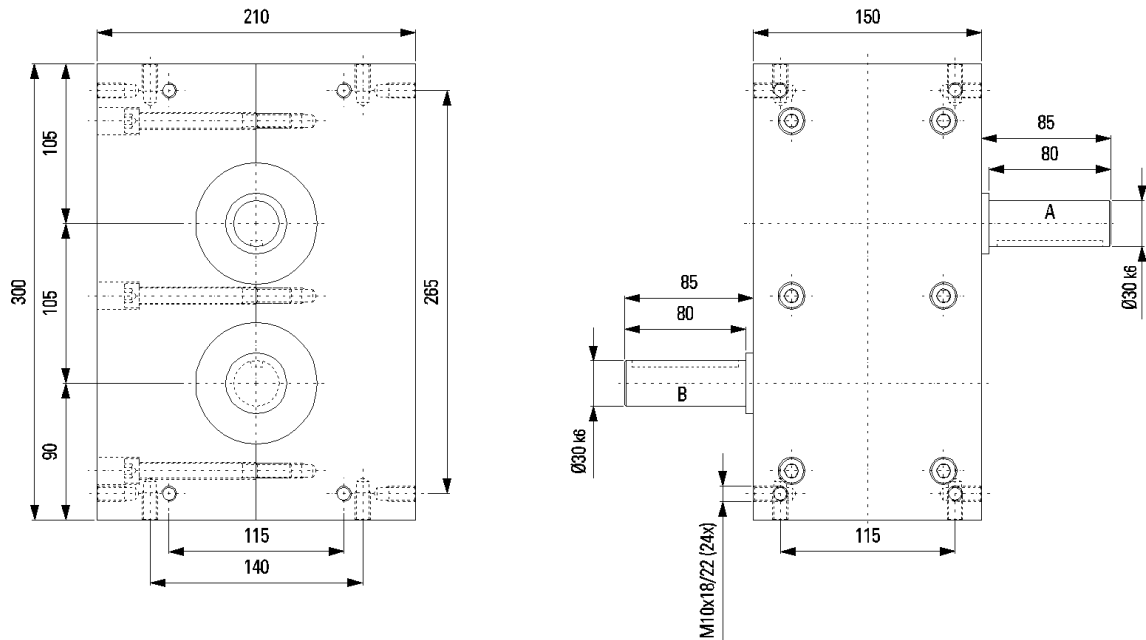

Fig. 15 Dimensional drawing XP 105

**Main dimensions**

Centre distance [mm]	105
Length x width x height [mm]	300 x 210 x 150
Parallel-Indexer without drive ca. [kg]	32
Standard internal transmission ratio	1,2,3,4,5,6,8,10,12
Direction	cw, ccw, oscillating
Installation orientation	universal

**Max. strain on input shaft**

Dynamic load rating [kN]	30.7
Static load rating [kN]	19

**Max. strain on output shaft**

Dynamic load rating [kN]	30.7
Static load rating [kN]	19

**3.7.7 Parallel-Indexer type XP 130**

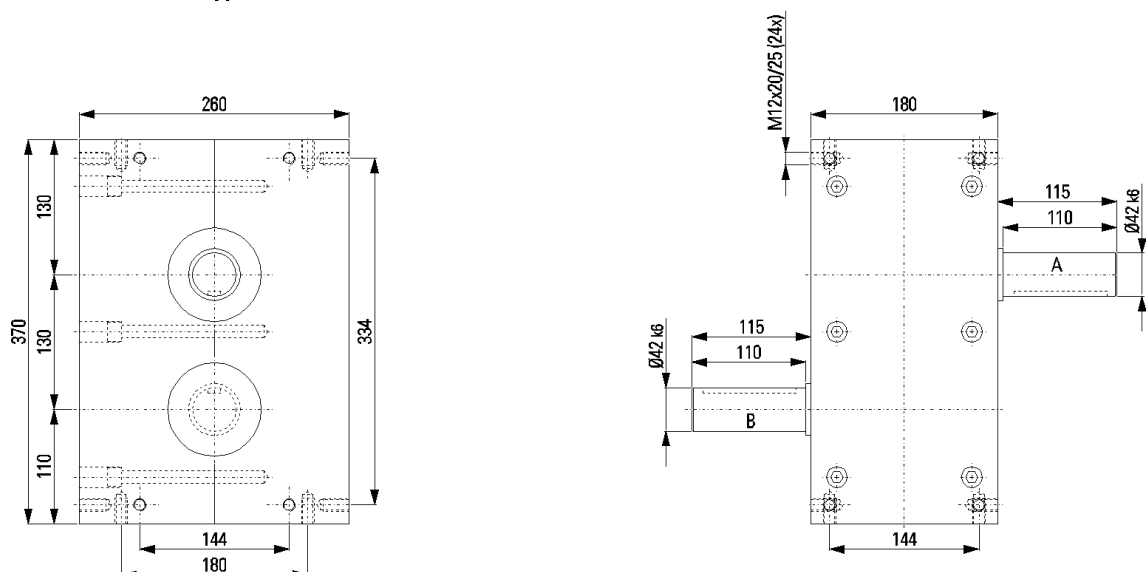





Fig. 16 Dimensional drawing XP 130

**Main dimensions**

Centre distance [mm]	130
Length x width x height [mm]	370 x 180 x 260
Parallel-Indexer without drive ca. [kg]	45
Standard internal transmission ratio	1,2,3,4,5,6,8,10,12
Direction	cw, ccw, oscillating
Installation orientation	universal

**Max. strain on input shaft**

Dynamic load rating [kN]	51
Static load rating [kN]	39

**Max. strain on output shaft**

Dynamic load rating [kN]	51
Static load rating [kN]	39

**3.7.8 Parallel-Indexer type XP 165**

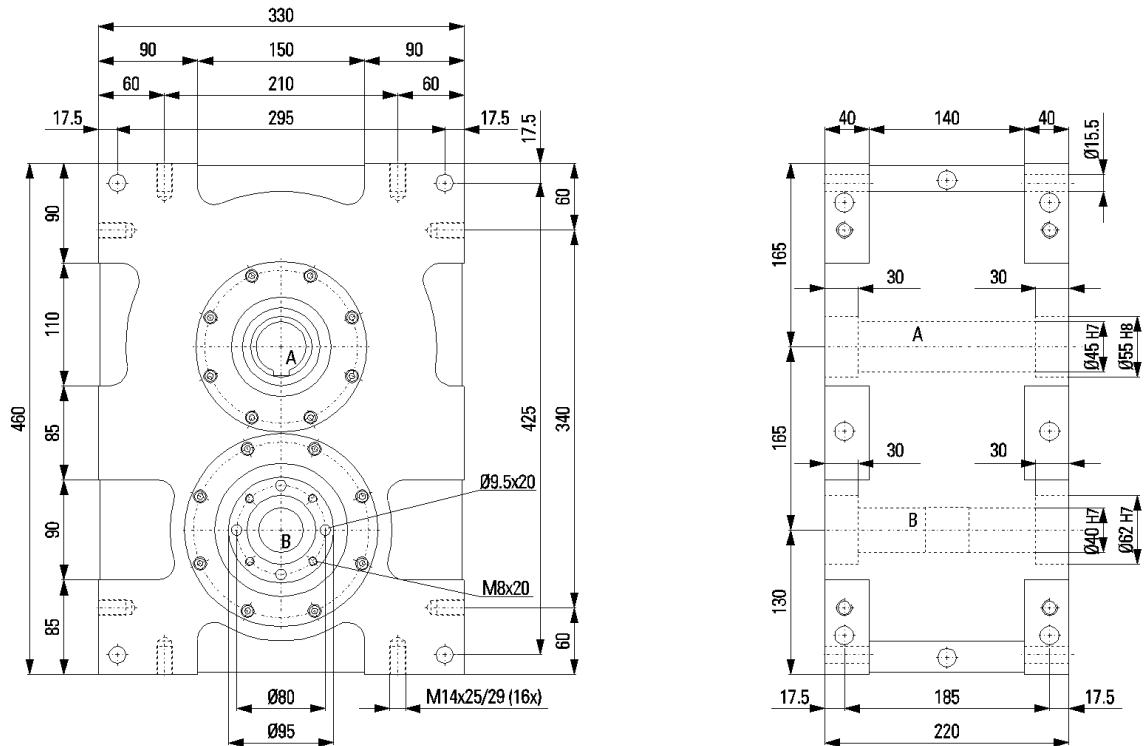

Fig. 17 Dimensional drawing XP 165

**Main dimensions**

Centre distance [mm]	165
Length x width x height [mm]	460 x 140 x 330
Parallel-Indexer without drive ca. [kg]	120
Standard internal transmission ratio	1,2,3,4,5,6,8,10,12
Direction	cw, ccw, oscillating
Installation orientation	universal

**Max. strain on input shaft**

Dynamic load rating [kN]	116
Static load rating [kN]	153

**Max. strain on output shaft**

Dynamic load rating [kN]	168
Static load rating [kN]	270



### 3.7.9 Parallel-Indexer type XP 200

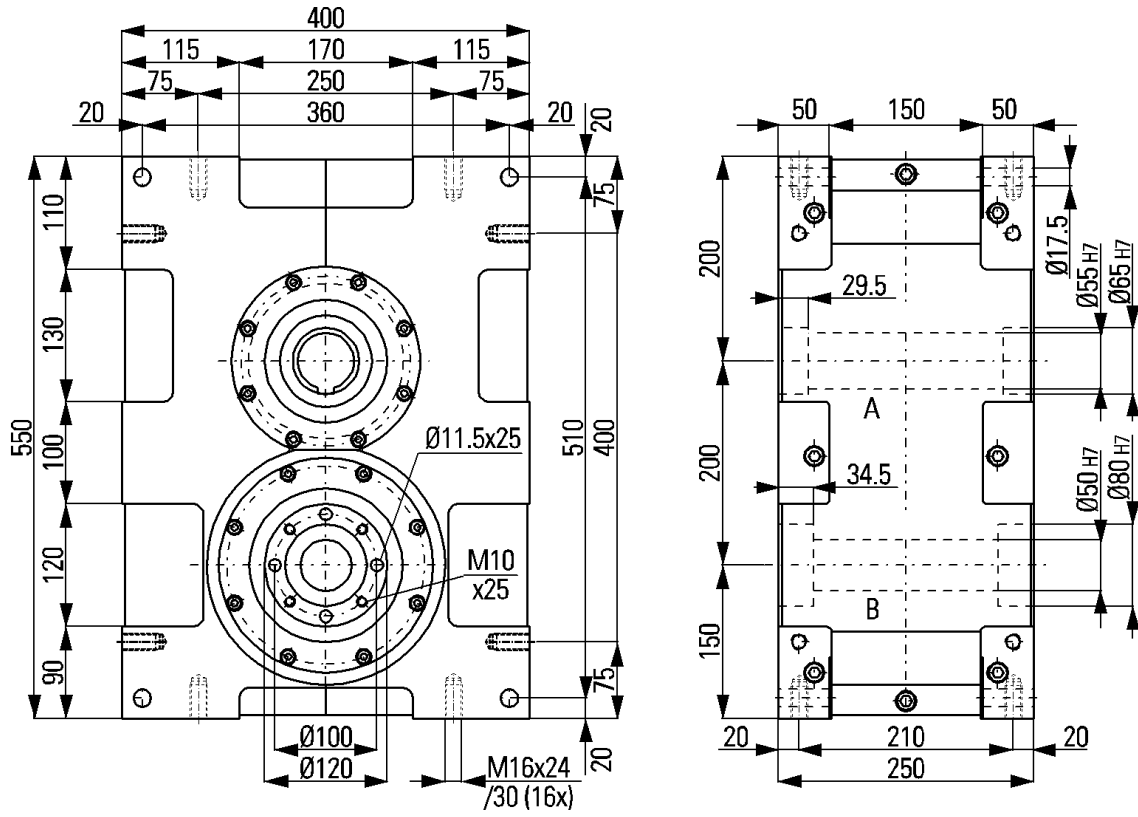

Fig. 18 Dimensional drawing XP 200

#### Main dimensions

Centre distance [mm]	200
Length x width x height [mm]	550 x 150 x 400
Parallel-Indexer without drive ca. [kg]	220
Standard internal transmission ratio	1,2, 3, 4, 5, 6, 8, 10, 12
Direction	cw, ccw, oscillating
Installation orientation	Universal

#### Max. strain on input shaft

Dynamic load rating [kN]	168
Static load rating [kN]	270

#### Max. strain on output shaft

Dynamic load rating [kN]	242
Static load rating [kN]	415



3.7.10 Parallel-Indexer type XP 250

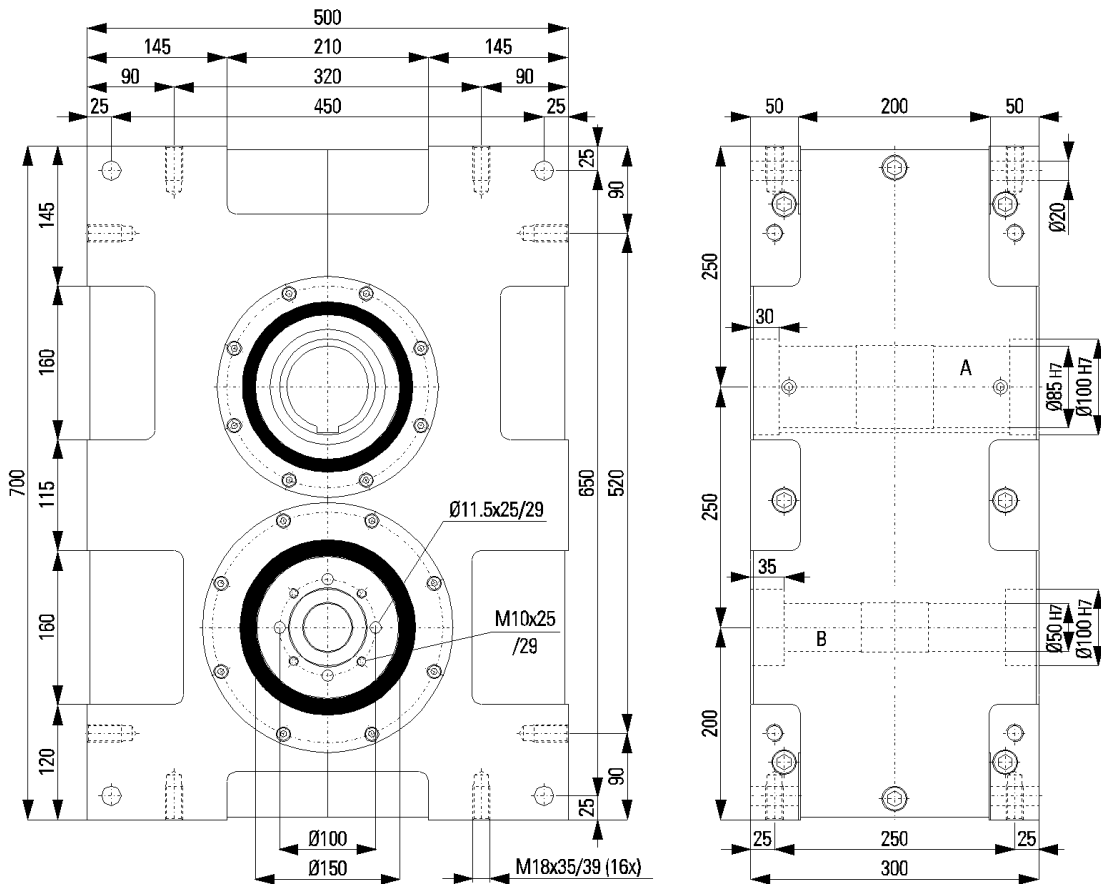

Fig. 19 Dimensional drawing XP 250

**Main dimensions**

Centre distance [mm]	250
Length x width x height [mm]	700 x 200 x 500
Parallel-Indexer without drive ca. [kg]	350
Standard internal transmission ratio	1,2, 3, 4, 5, 6, 8, 10, 12
Direction	cw, ccw, oscillating
Installation orientation	Universal

**Max. strain on input shaft**

Dynamic load rating [kN]	242
Static load rating [kN]	415

**Max. strain on output shaft**

Dynamic load rating [kN]	369
Static load rating [kN]	655



### 3.7.11 Parallel-Indexer type TP 040

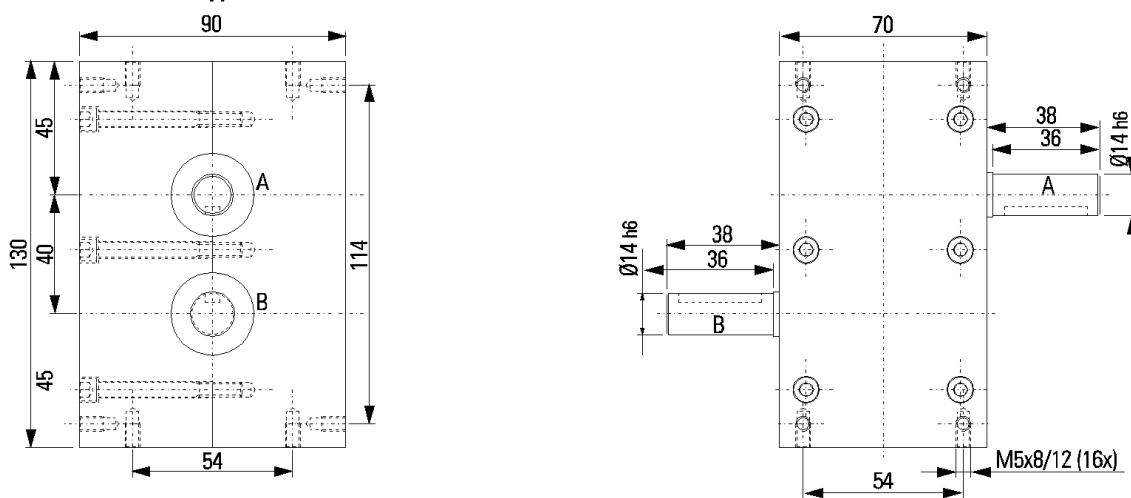

Fig. 20 Dimensional drawing TP 040

#### Main dimensions

Centre distance [mm]	40
Length x width x height [mm]	130 x 70 x 90
Parallel-Indexer without drive ca. [kg]	2
Standard internal transmission ratio	1,2, 3, 4, 5, 6, 8, 10
Direction	cw, ccw, oscillating
Installation orientation	universal
<b>Max. strain on input shaft</b>	
Dynamic load rating [kN]	4.36
Static load rating [kN]	2.24
<b>Max. strain on output shaft</b>	
Dynamic load rating [kN]	4.36
Static load rating [kN]	2.24



**3.7.12 Parallel-Indexer type TP 063**

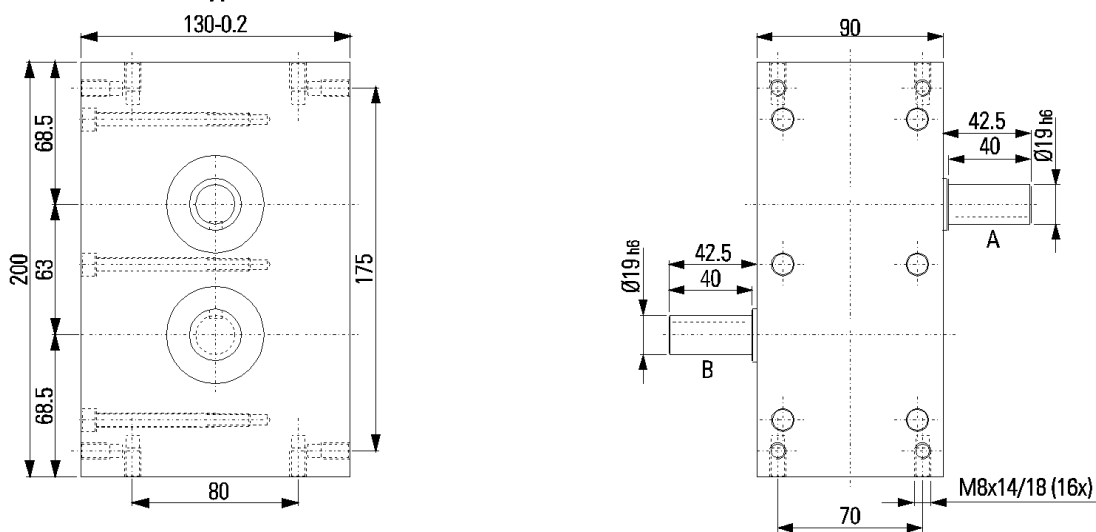

Fig. 21 Dimensional drawing TP 063

**Main dimensions**

Centre distance [mm]	63
Length x width x height [mm]	200 x 90 x 1300
Parallel-Indexer without drive ca. [kg]	8
Standard internal transmission ratio	1,2, 3, 4, 5,6, 8, 10, 12
Direction	cw, ccw, oscillating
Installation orientation	universal
<b>Max. strain on input shaft</b>	
Dynamic load rating [kN]	11.9
Static load rating [kN]	6.55
<b>Max. strain on output shaft</b>	
Dynamic load rating [kN]	8.06
Static load rating [kN]	4.75





3.7.14 Parallel-Indexer type TP 100

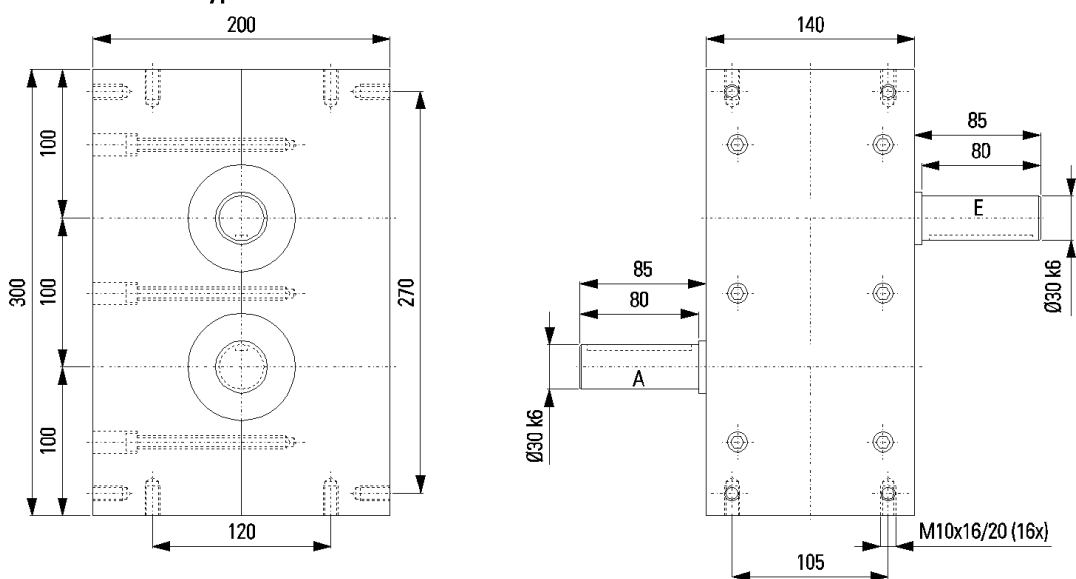

Fig. 23 Dimensional drawing TP 100

**Main dimensions**

Centre distance [mm]	100
Length x width x height [mm]	300 x 140 x 200
Parallel-Indexer without drive ca. [kg]	25
Standard internal transmission ratio	1,2,3,4,5,6,8,10,12
Direction	cw, ccw, oscillating
Installation orientation	universal

**Max. strain on input shaft**

Dynamic load rating [kN]	27
Static load rating [kN]	15.3

**Max. strain on output shaft**

Dynamic load rating [kN]	27
Static load rating [kN]	15.3



### 3.7.15 Parallel-Indexer type TP 125

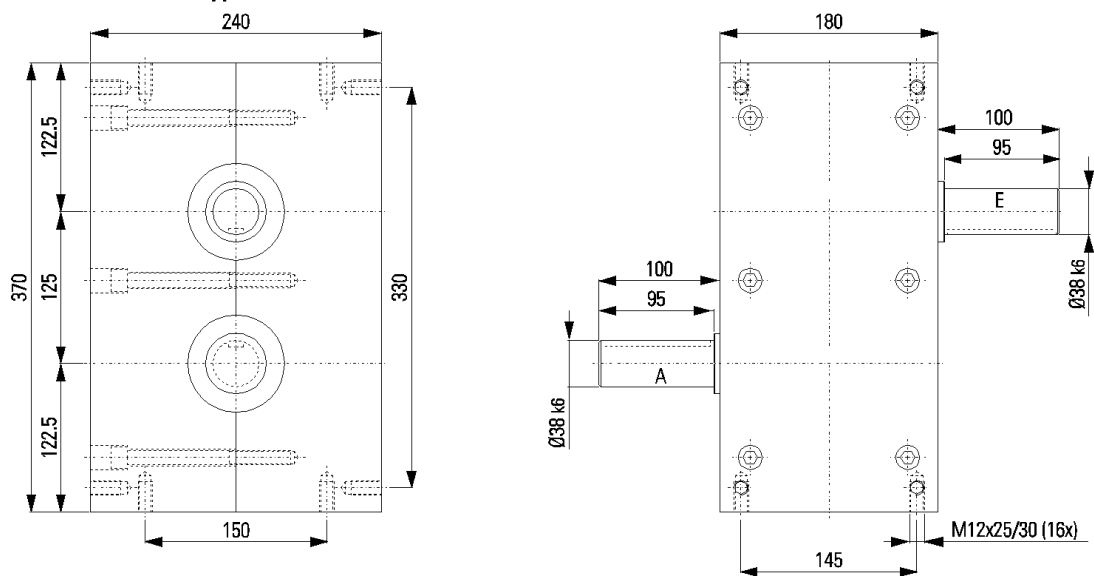

Fig. 24 Dimensional drawing TP 125

#### Main dimensions

Centre distance [mm]	125
Length x width x height [mm]	370 x 180 x 240
Parallel-Indexer without drive ca. [kg]	45
Standard internal transmission ratio	1,2, 3, 4, 5,6, 8, 10, 12
Direction	cw, ccw, oscillating
Installation orientation	universal

#### Max. strain on input shaft

Dynamic load rating [kN]	40
Static load rating [kN]	28

#### Max. strain on output shaft

Dynamic load rating [kN]	40
Static load rating [kN]	28





3.7.16 Parallel-Indexer type TP 160

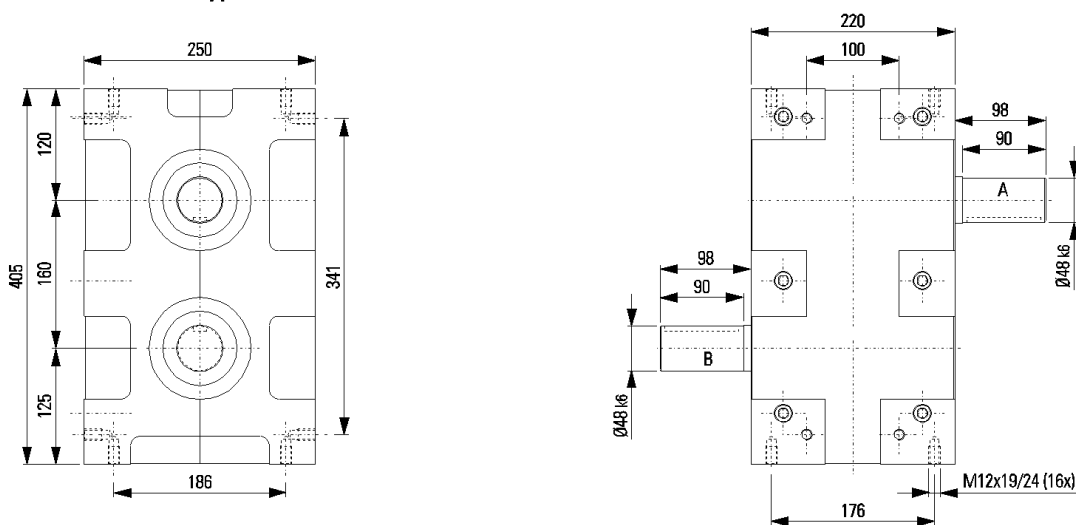

Fig. 25 Dimensional drawing TP 160

**Main dimensions**

Centre distance [mm]	160
Length x width x height [mm]	405 x 220 x 250
Parallel-Indexer without drive ca. [kg]	117
Standard internal transmission ratio	1,2, 3, 4, 5,6, 8, 10, 12
Direction	cw, ccw, oscillating
Installation orientation	universal

**Max. strain on input shaft**

Dynamic load rating [kN]	51
Static load rating [kN]	39

**Max. strain on output shaft**

Dynamic load rating [kN]	168
Static load rating [kN]	270



3.7.17 Parallel-Indexer type SP 105

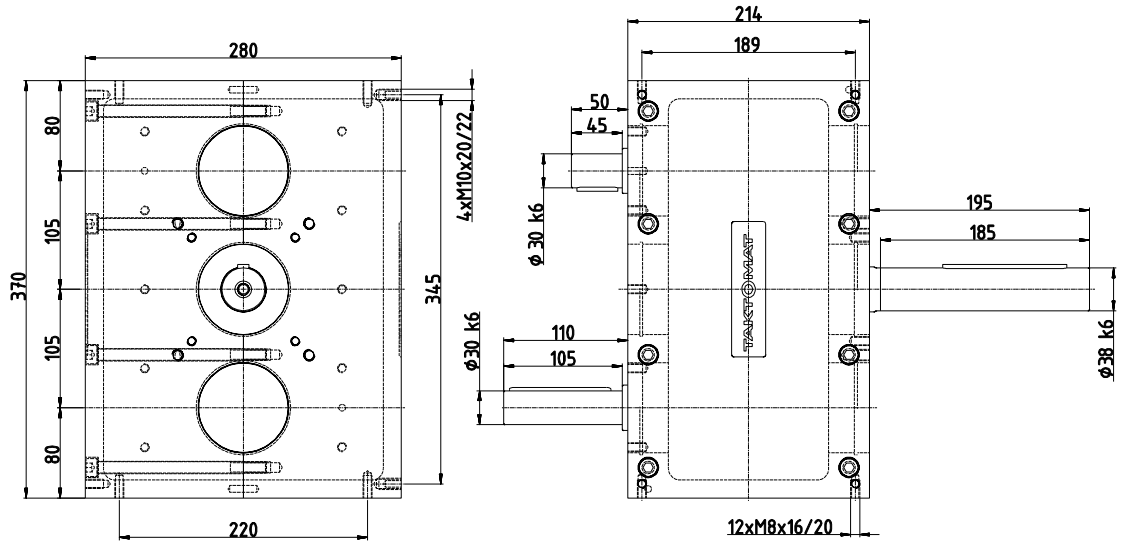

Fig. 26 Dimensional drawing SP 105

**Main dimensions**

Centre distance [mm]	105
Length x width x height [mm]	370 x 214 x 280
Parallel-Indexer without drive ca. [kg]	50
Standard internal transmission ratio	1,2, 3, 4, 5, 6, 8, 10, 12
Direction	cw, ccw, oscillating
Installation orientation	universal

**Max. strain on input shaft**

Dynamic load rating [kN]	30.7
Static load rating [kN]	19

**Max. strain on output shaft**

Dynamic load rating [kN]	30.7
Static load rating [kN]	19



### 3.8 Ambient conditions

Following ambient conditions apply to all Parallel-Indexer described in this operating manual.



#### NOTICE

**Deviating ambient conditions can cause material damage.**

**Do not operate in deviating ambient conditions.**

- ▶ Adhere to the given operating – and storage conditions.
- ▶ Other ambient condition only in consultation with Taktomat.

#### 3.8.1 Operating conditions

Area of application	<b>Inside</b>
Temperature range [°C]	<b>+10 to + 40</b>
Relative humidity [%]	<b>max 40 to 70</b>
Media	<b>do not expose the system to any aggressive agents</b>



### 3.8.2 Storage conditions

Area of application	Inside
Lighting [Lux]	min. 300
Temperature range [°C]	-22 to + 50
Relative air humidity [%]	max. 40 to 70
Media	<b>do not expose the system to any aggressive agents</b>
Storage period > 6 month	<b>coat the machine with corrosive protection</b>

### 3.8.3 Noise emission

The direct noise emission from the machine depends upon the ambient conditions. Deduced from these conditions there must be further acoustic pressure measurements performed on the installation location of the machine.



## 4 Transport

### 4.1 Safety information

#### NOTICE



**Damage arising from improper transport!**  
**Improper transport can cause significant damage to property.**

- ▶ Take care and take note of the symbols on the packaging when unloading the machine on delivery and when transporting it on the premises.

### 4.2 Transport inspection

Immediately on receipt, check to make certain that the delivery is complete and has not been damaged during transport:

Proceed as follows if there are visible signs of damage during transport:

- ▶ Do not accept the delivery or only do so conditionally.
- ▶ Record the extent of the damage on the transport documentation or on the associated delivery note.
- ▶ Immediately report any damage to the manufacturer of the machine.

#### ⚠ DANGER



**Risk of fatal injury from suspended loads and falling parts!**  
**Parts can fall during transport and cause serious or fatal injury.**

- ▶ Do not walk under suspended loads.
- ▶ Keep people clear of the danger zone.
- ▶ Always use lifting gear with a sufficient load capacity.
- ▶ Always use forklift trucks or pallet trucks with a sufficient load capacity and fork length.
- ▶ Do not leave the load suspended if you leave the working area.

### 4.3 Packaging, handling, unpacking

The machine is packed in plastic sheeting or cardboard packaging and secured to a pallet for transportation.

#### NOTICE



**Damage arising from improper transport!**  
**Improper transport can cause significant damage to property.**

- ▶ The machine must not be allowed to become wet while it is being transported.
- ▶ Take the machine out of the packaging just before installation

- ▶ Remove the packaging carefully and dispose of it with due regard to environmental considerations.



#### 4.3.1 Transport using sling equipment

Staff Protective equipment

Qualified staff



- ▶ The sling equipment (see figure) must be attached to the attachment points (see table and dimensions sheet) in the positions shown in the figure and checked to ensure that it is working correctly (see the instructions for the sling equipment).

Transport the machine as follows if you are using sling equipment:

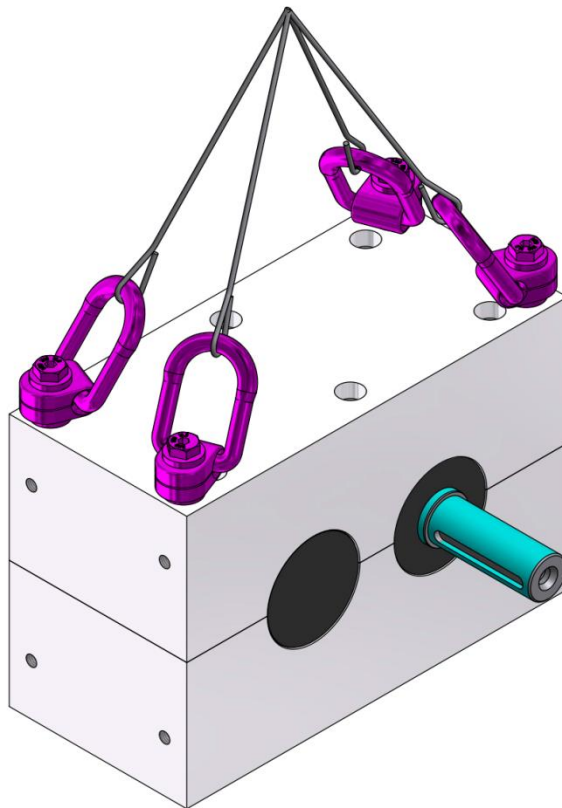

Fig. 27 Transport with Eyebolts

**Lifting instructions:**

The angle between the perpendicular and the sling chain must lie between 0° and 45°.

**NOTICE****Damage arising from improper transport!**

**Improper transport can cause significant damage to property.**

- ▶ Take care and take note of the symbols on the packaging when unloading the machine on delivery and when transporting it on the premises
- ▶ Use slinging equipment with sufficient load capacity
- ▶ Align slinging equipment in load direction.
- ▶ If the recommended angle between perpendicular and the sling chain or sling strap exceeds 45° the load capacity of the sling equipment is reduced.

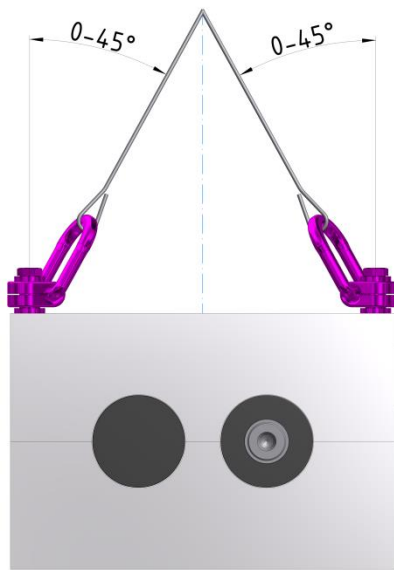

Fig. 28 Lifting Instruction Error



## 5 Mechanical installation

### 5.1 Installation orientation

Possible Installation orientations.

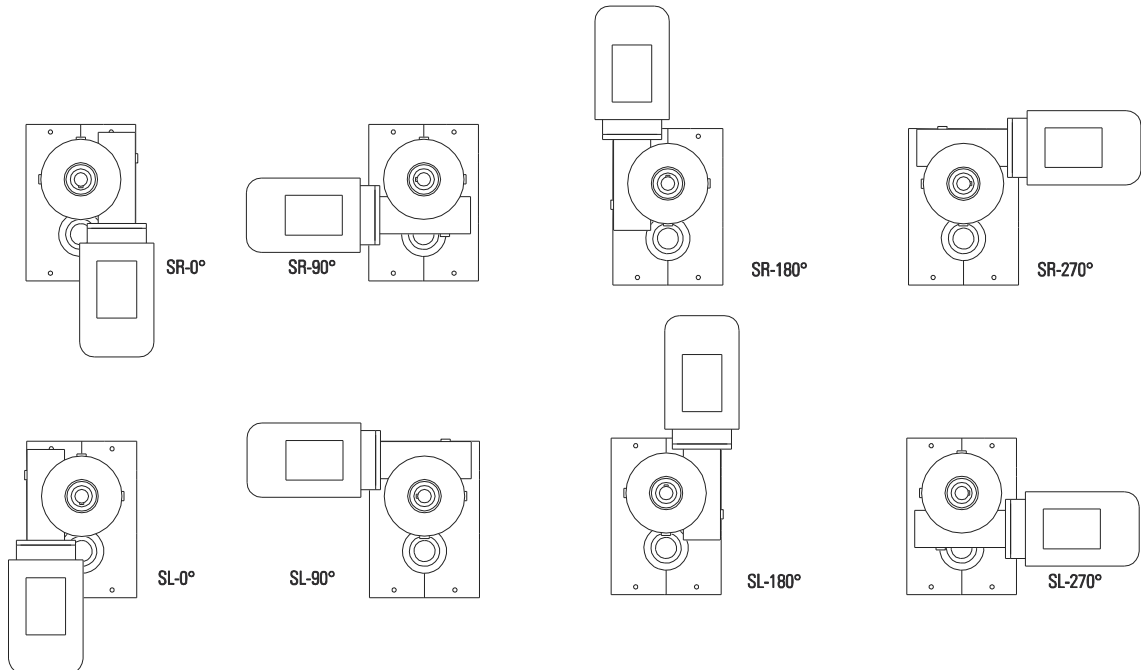

Fig. 29 Drive installation orientation

### NOTE



**Damage arising from improper installation of the drive!**

**Improper installation of the drive can cause significant damage to property and material.**

- ▶ Always follow the original operating instructions of the drive manufacturer on mounting the drive (Standard SEW) to the machine.
- ▶ Oil control – and drain bolts as well as air escape valves must be freely accessible without mechanical intervention.



## 5.2 Installation and commissioning

### 5.2.1 Safety information

#### **⚠ DANGER**



#### Risk of death by electrocution!

There is an immediate risk of fatal injury due to electric shock if live components are touched. Damage to the insulation or to individual components can cause fatal injury.

- ▶ Only allow work on the electrical system to be carried out by qualified electrical engineers.
- ▶ In the event of damage to the insulation, immediately shut off the power supply and initiate a repair.
- ▶ Before starting work on active parts of the electrical system or equipment, ensure that it is completely powered down and cannot be switched on again.

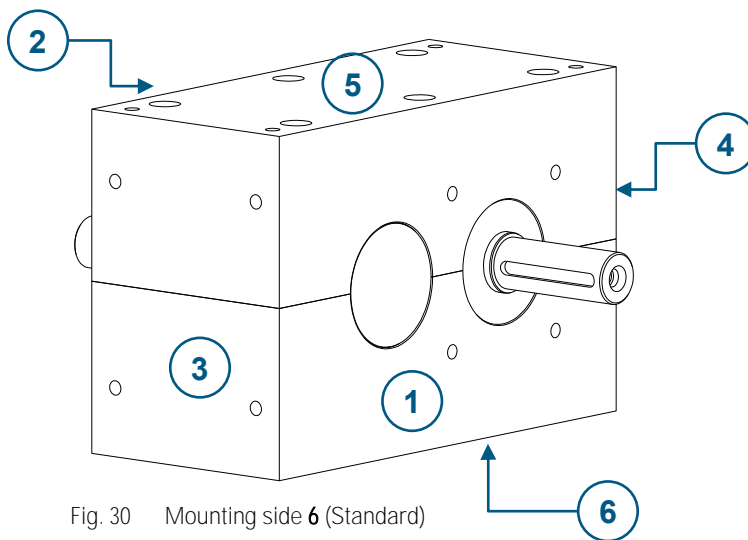

Fig. 30 Mounting side 6 (Standard)

### 5.2.2 Installation

#### Staff      Protective equipment

Qualified staff



- ▶ The surface on which the machine is to be installed must be level.
- ▶ Clean the installation surface and apply a film of oil.
- ▶ Place the Parallel-Indexer XP - TP – SP on the installation surface.
- ▶ Secure the Parallel-Indexer XP - TP – SP with screws and studs according to requirements.
- ▶ Compare the power supply with the details on the rating plate.
- ▶ Connect the drive unit.
- ▶ The housing of the Parallel-Indexer XP - TP – SP has to be earthed consistently according to the VDE regulations with adequate width.

#### Securing the drive

The drive must be secured with bolts at the specified points. It is possible to connect a servo motor or a three-phase motor to the machine.

On request, Taktomat can supply an adapter flange for use between the drive and the machine housing.

The input shaft must not be remachined. The diameter and length of the hollow shaft of the drive are determined by the dimensions of the input shaft (refer to the dimensions sheet for information).



## 6 Service and maintenance

The machine is designed to be largely maintenance-free. Necessary maintenance is intended to keep the machine fit for service. The intervals will depend on the operating conditions.

### Note:

**The maintenance intervals given are minimum recommendations based on use across three shifts. Failure to observe the maintenance stipulations and any changes will make the guarantee null and void and release the manufacturer from any liability.**

Make sure that you observe any statutory requirements, stipulations and national regulations in respect of occupational health and environmental protection.

The maintenance stipulations only apply in conjunction with the operating instructions of the manufacturer concerned. The contents are subject to change without notice.

### 6.1 Safety information in respect of maintenance



#### **WARNING**

**Danger if staff are insufficiently qualified!**

**Persons who are inadequately qualified are unable to assess the risks associated with working on the machine and expose themselves and others to the risk of serious or fatal injury.**

- ▶ Ensure that all work is performed only by suitably qualified persons.
- ▶ Keep insufficiently qualified persons at a safe distance from the working area.

#### 6.1.1 Qualified staff required

The operator must unambiguously specify who is responsible for cleaning, maintenance and servicing and how such work is to be performed.

Only allow qualified, trained and properly instructed staff to work on the machine.

#### 6.1.2 Maintenance tasks

If servicing work is to be performed in-house, the appropriate tools and equipment for such work must be provided. Follow the procedures laid down in the Operating Instructions for switching the system on and off when performing any maintenance and cleaning work.

Observe the stipulations laid down in the Operating and Maintenance Instructions with respect to adjustment, maintenance and servicing activities, including details on replacing components and equipment.

Where necessary, cordon off the area in which maintenance is being carried out at a safe distance.

#### 6.1.3 Cleaning

Make sure that all handles, steps, handrails, platforms, ladders are clean.

Compressed air must not be used for cleaning.

Before starting maintenance work, clean any oil, fuel or cleaning agents from the machine, and particularly from connections and screwed joints. Do not use aggressive cleaning agents. Use lint-free cloths.

After cleaning, check all supply lines to ensure that they do not leak, that no connections have come loose, and that they show no signs of abrasion or damage. Immediately rectify any faults.

#### Concluding work

Always tighten any screw connections that have been released during maintenance and service work. If safety equipment has to be removed during setup, maintenance or repairs, the safety equipment must be replaced and tested immediately work has been completed.

Dispose of service fluids, process materials, cleaning agents and used parts safely and in an environmentally friendly manner. Follow the manufacturer's instructions when dealing with hazardous substances.

#### Replacement parts

Replacement parts must comply with the technical requirements laid down by the manufacturer. This is guaranteed with original replacement parts.



### Environmental protection

Take note of the following environmental protection information when carrying out maintenance work:

- ▶ Remove excess grease or oil from the lubrication points and dispose of it in accordance with local regulations.

## 6.2 Maintenance tasks

### 6.2.1 Maintenance plan

Interval	Maintenance activity	Staff
Daily	General visual and acoustic inspection	Operator
Three-monthly	Check that no oil is escaping from the machine.	Operator
Half a year	<ul style="list-style-type: none"> <li>▶ Visual inspection for damage.</li> <li>▶ Remove any dust deposits (especially on ventilation grills of the drive units).</li> <li>▶ Inspect electric cables for damage.</li> </ul>	Qualified staff
Once a year	Inspect the machine for play in the dwell phases.	Qualified staff

## 6.3 Checking the oil level

The Parallel-Indexer is life-time lubricated.!



## 6.4 Lubrication

### 6.4.1 Requirements for lubricants

#### General

To ensure safe operation and a long service life, it is necessary to lubricate the machine carefully. The specified oil and grease must be applied to all lubrication points.

Carefully clean dirty lubrication points using a suitable agent and then lubricate them with new lubricant. After lubrication, any excess lubricant must be removed and properly disposed of.

The oil and grease used must be silicone-free.

#### Lubricating oil

Use only lubricating oil compliant with DIN 51 517 (ISO VG 460 )

#### Recommended gear oil

Manufacturer	Designation
Mobil	Mobilgear 600 XP 460
BP	Energol GR-XP 460
SHELL	Omala 460
LIQUI MOLY	meguin Getriebeöl CLP 460
Zeller+Gmelin	Divinol ICL ISO 460
Klüber	Klüberoil GEM 1 N

#### Lubricating grease

Use only lubricating grease compliant with DIN 51 825-KP 2K.

#### Recommended lubricating grease:

Manufacturer	Designation
Mobil	Mobilux EP2
BP	
SHELL	
LIQUI MOLY	
Zeller+Gmelin	Divinol Fett EP 2
Klüber	-
THK	THK lubricant AFA

#### Note:

Only use lithium soap based grease for lubrication. The use of greases based on different materials causes gummy deposits, decomposes the grease and destroys its lubricating properties.

### 6.4.2 Oil quantity

Type	Fill quantity [l] [dm <sup>3</sup> ]	Type	Fill quantity [l] [dm <sup>3</sup> ]
XP030	0.0022	TP040	0.15
XP040	0.15	T063	0.4
XP050	0.2	TP080	0.75
XP065	0.4	TP100	1.3
XP080	0.75	TP125	2
XP105	1	TP160	3.2
XP130	2.7		
XP165	6.5		
XP200	9.5		
XP250	17.5		
Type	Fill quantity [l] [dm <sup>3</sup> ]		



Type	Fill quantity [l] [dm <sup>3</sup> ]	Type	Fill quantity [l] [dm <sup>3</sup> ]
SP105	1.5		



## 6.5 Replacing cam follower

The machine must first be isolated from the power supply to allow the Motion Index Drives cam follower (TKR) to be removed and maintained safely and efficiently. Any external accessories that obstruct access to the cam follower must be removed correctly.

The following assembly sequence must be strictly adhered to.

### 6.5.1 Replacing cam follower assembly sequence TP040-100 / XP030-130

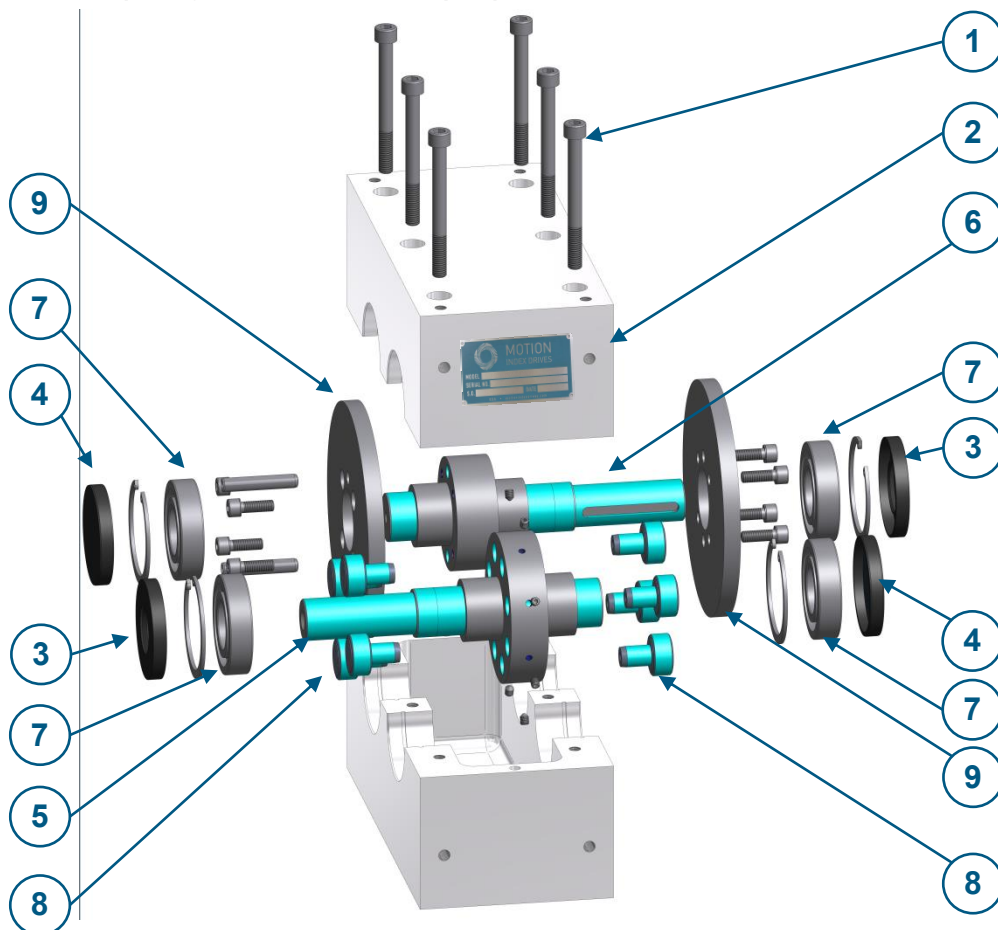

Fig. 31 Detail Replacing cam follower assembly sequence TP040-100 / XP030-130

Item	Designation
1	6x Allen screw
2	Housing upper part
3	Shaft seal
4	Sealing cap
5	Star wheel / output
6	Input shaft / input
7	Bearings
8	Cam follower / TKR
9	Cam set



Step	Action
(1)	▶ Unscrew 6x Allen screws <b>1</b> .
(2)	▶ Remove housing upper part
(3 und 4)	▶ Remove shaft seals <b>3</b> and sealing caps <b>4</b> .
(5 und 6)	▶ Remove star wheel <b>5</b> and input shaft <b>6</b> with all other parts of the lower housing part
(7)	▶ Remove bearings with an appropriate tool
(8)	▶ Remove securing screws from the star wheel ▶ Press cam follower <b>8</b> out of the star wheel with an appropriate tool



**6.5.2 Replacing cam follower assembly sequence TP125-160**

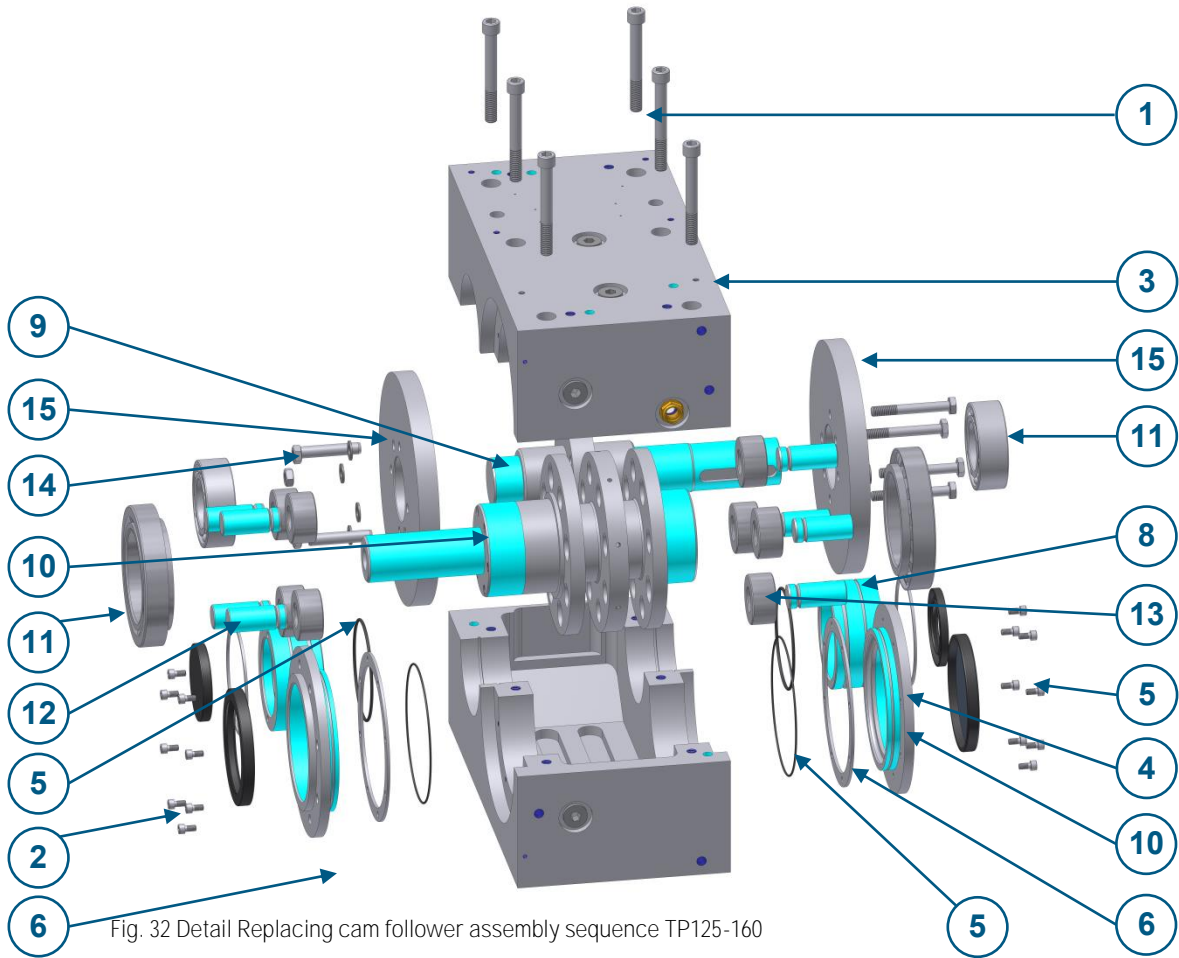

Fig. 32 Detail Replacing cam follower assembly sequence TP125-160

Item	Designation
1	6x Allen screw
2	8x Allen screw
3	Housing upper part
4	2x Output flange
5	2x O-Ring
6	2x Shim
7	2x Shaft seal
8	2x Eccentric ring
9	Input shaft / input
10	Star wheel / output
11	Bearings
12	Pin
13	Cam follower
14	Screw
15	Cam set





Step	Action
(1)	▶ Unscrew 6x Allen screws <b>1</b>
(2)	▶ Mark position of eccentric ring <b>8</b> ▶ Unscrew 16x Allen screws <b>5</b> of output flange
(3)	▶ Remove housing upper part
(4 und 5)	▶ Remove 2x output flange <b>4</b>
(6)	▶ Remember position of shims and remove them
(7)	▶ Remove input shaft <b>9</b> and star wheel <b>10</b> with all other parts of the lower housing part
(8)	▶ Remove the Bearings <b>11</b> together with the eccentric ring <b>8</b> from star wheel <b>10</b> with an appropriate tool
(9)	▶ Remove securing screws from the star wheel ▶ Press pin <b>12</b> out of the star wheel with an appropriate tool. ▶ Remove cam follower <b>13</b>



**6.5.3 Replacing cam follower assembly sequence XP165-250**

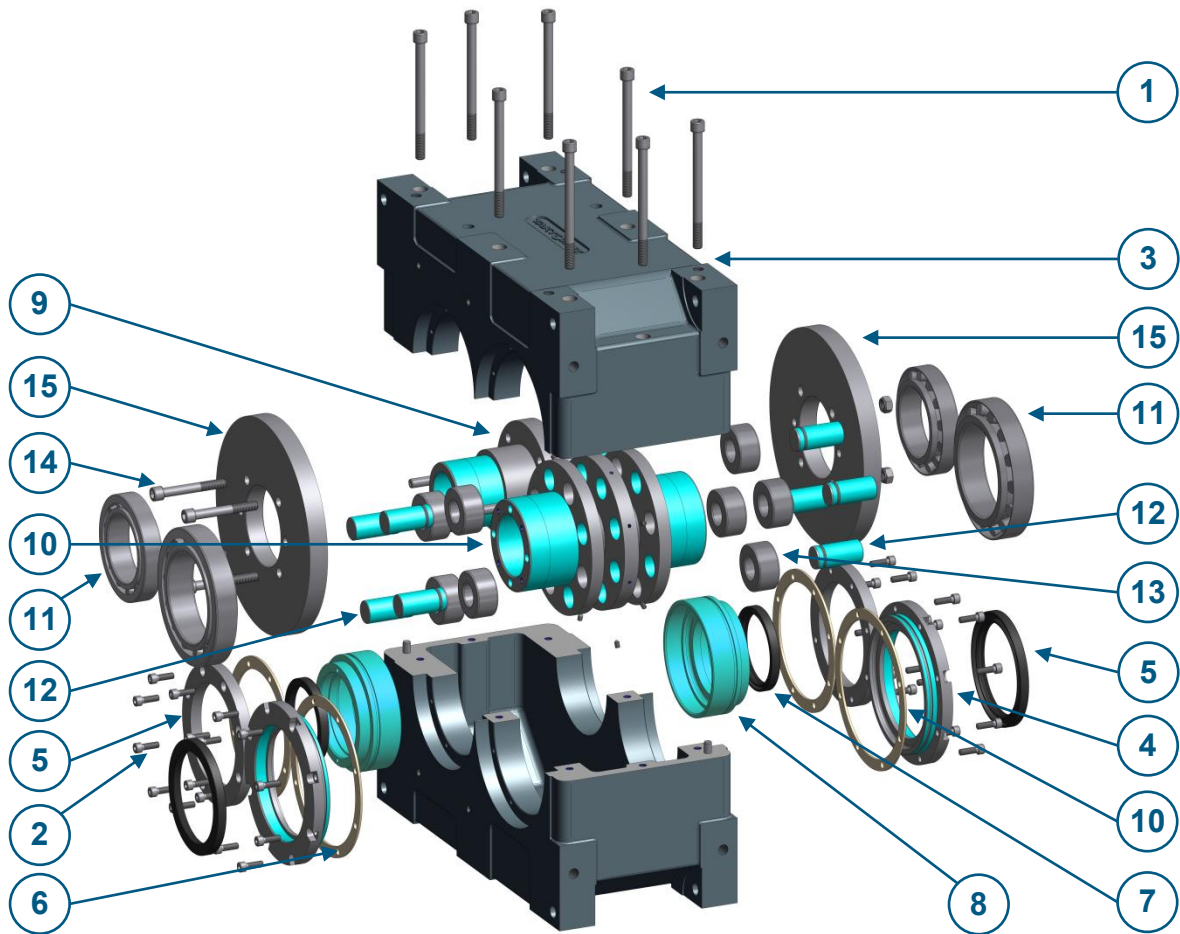

Fig. 33 Detail Replacing cam follower assembly sequence XP165-250

Item	Designation
1	8x Allen screw
2	32x Allen screw
3	Housing upper part
4	2x Output flange
5	2x Input flange
6	4x Shim
7	2x Shaft seal
8	2x Eccentric ring
9	Input shaft / input
10	Star wheel / output
11	Bearings
12	Pin
13	Cam follower
14	Allen screw
15	Cam set



Step	Action
(1)	▶ Unscrew 8x Allen screws <b>1</b>
(2)	▶ Mark position of eccentric ring <b>8</b> ▶ Unscrew 32x Allen screw <b>2</b>
(3)	▶ Remove housing upper part
(4 und 5)	▶ Remove 2x drive flange <b>4</b> and input flange <b>5</b> .
(6)	▶ Remember position of shims and remove them
(7)	▶ Remove input shaft <b>9</b> and star wheel <b>10</b> with all other parts of the lower housing part
(8)	▶ Remove the Bearings <b>11</b> together with the eccentric ring <b>8</b> from star wheel <b>10</b> with an appropriate tool
(9)	▶ Remove securing screws from the star wheel ▶ Press pin <b>12</b> out of the star wheel with an appropriate tool. ▶ Remove cam follower <b>13</b>



**6.5.4 Replacing cam follower assembly sequence SP105**

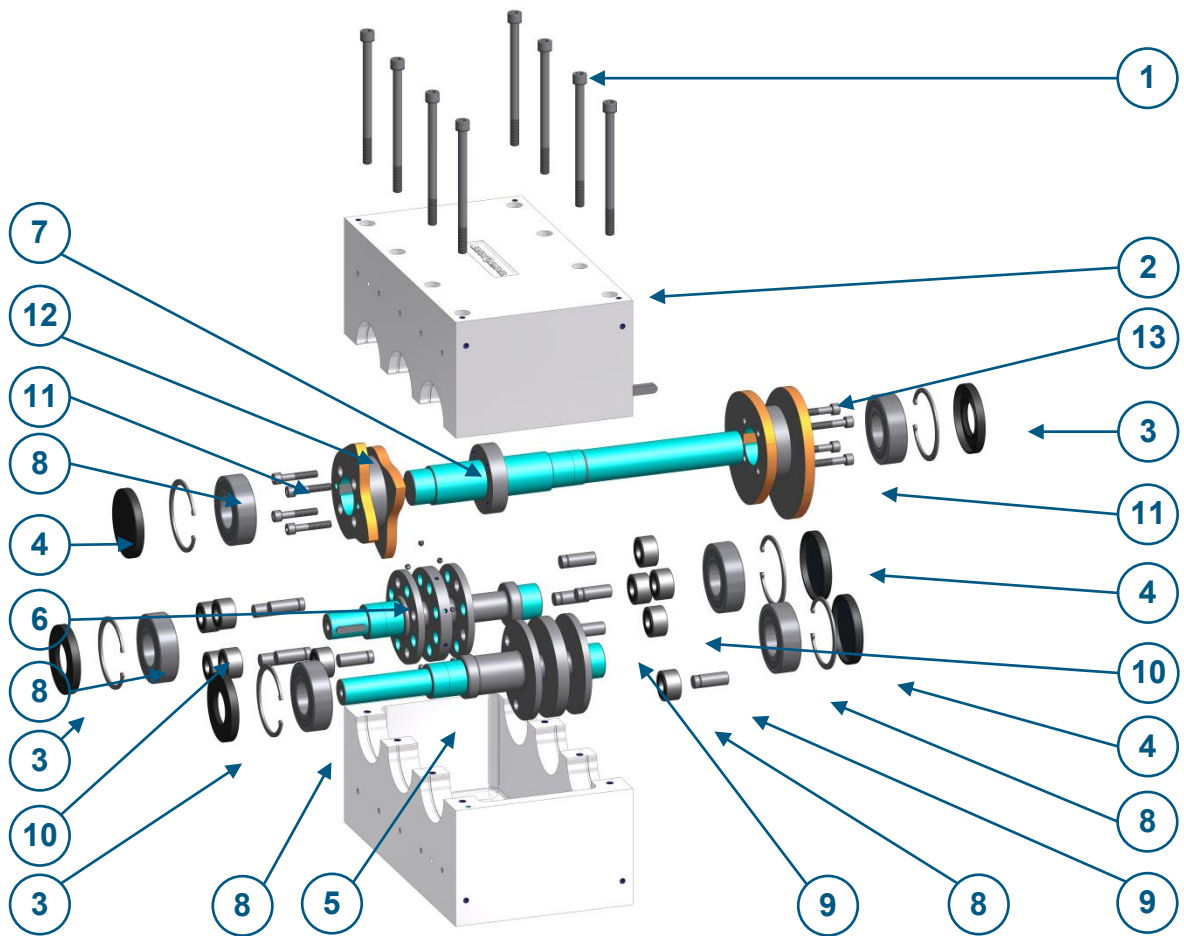

Fig. 34 Detail Replacing cam follower assembly sequence SP105

Item	Designation
1	8x Allen screw
2	Housing upper part
3	3x Shaft seal
4	3x Sealing cap
5	Star wheel (output) 1 (oscillation)
6	Star wheel (output) 2 (step)
7	Input shaft
8	Bearings
9	Pin
10	Cam follower
11	8x Allen screw
12	Cam set
13	Cam set (oscillation)



Step	Action
(1)	▶ Unscrew 8x Allen screws <b>1</b>
(2)	▶ Remove housing upper part
(3 und 4)	▶ Remove shaft seals <b>3</b> and sealing cap <b>4</b>
(5)	▶ Remove star wheel (output 1) <b>5</b> and (output 2) <b>6</b> as well as the input shaft <b>7</b> with all other parts of the lower housing part
(6)	▶ Remove the bearings from the star wheel (output 1) <b>5</b> with an appropriate tool ▶ Remove the bearings from the star wheel (output 1) <b>6</b> with an appropriate tool
(7)	▶ Remove securing screws from the star wheel ▶ Press pin <b>9</b> out of the star wheel with an appropriate tool. ▶ Withdraw the cam followers <b>10</b>



## 7 Troubleshooting

### 7.1 Safety information

#### DANGER



**Risk of death by electrocution!**

There is an immediate risk of fatal injury due to electric shock if live components are touched. Damage to the insulation or to individual components can cause fatal injury.

- ▶ Only allow work on the electrical system to be carried out by qualified electrical engineers.
- ▶ In the event of damage to the insulation, immediately shut off the power supply and initiate a repair.
- ▶ Before starting work on active parts of the electrical system or equipment, ensure that it is completely powered down and cannot be switched on again.

#### WARNING



**Risk of injury from improper troubleshooting!**

Improper troubleshooting can cause serious injury to staff and material.

- ▶ Before starting work ensure that there is sufficient room to carry out the work.
- ▶ Pay attention to tidiness and cleanliness in the working area! Loose parts and tools which are piled up or lying around are sources of accidents.

Fault	Possible cause	Remedy
Drive does not turn	<ul style="list-style-type: none"> <li>• No supply voltage</li> <li>• Drive contactor malfunction</li> <li>• Drive protection switch triggered</li> <li>• Brake not released</li> </ul>	<ul style="list-style-type: none"> <li>▶ Check power supply</li> <li>▶ Change contactor</li> <li>▶ Let the the drive cool down; latch the protection switch of the drive</li> <li>▶ Incorrectly connected or worn brake</li> <li>▶ Check sensor settings at the switching cam.</li> <li>▶ Check sensor cable at the sensor.</li> </ul>
Drive turns, but output flange does not turn and output flange is free of play.	<ul style="list-style-type: none"> <li>• Worm gear malfunction</li> <li>• Safety coupling overload / disengaged</li> <li>• Cam followers tear off due to massive overload</li> <li>• Levers broken</li> </ul>	<ul style="list-style-type: none"> <li>▶ Contact Motion Index Drives</li> <li>▶ Remove outside blockade / latch the safety coupling</li> <li>▶ Contact Motion Index Drives</li> </ul>
Drive turns, but output flange does not turn, output flange is not free of play.	<ul style="list-style-type: none"> <li>• Cam follower tear off due to overload</li> </ul>	<ul style="list-style-type: none"> <li>▶ Contact Motion Index Drives</li> <li>▶</li> </ul>
Drive turns with strong humming noise	<ul style="list-style-type: none"> <li>• Drive operates on 2 phases</li> </ul>	<ul style="list-style-type: none"> <li>▶ Check fuse or drive contactor</li> <li>▶ Measure current on all 3 phases; voltage measurement is not enough</li> </ul>
No signal from sensor	<ul style="list-style-type: none"> <li>• Sensor not activated / not fully activated</li> <li>• Cable defective</li> <li>• Sensor defective</li> <li>• No supply voltage</li> </ul>	<ul style="list-style-type: none"> <li>▶ Remove blockage</li> <li>▶ Check cable, exchange if necessary</li> <li>▶ Exchange sensor</li> <li>▶ Check supply voltage</li> </ul>



## 8 Disassembly



### **! DANGER**

**Risk of death by electrocution!**

**There is an immediate risk of fatal injury due to electric shock if live components are touched. Damage to the insulation or to individual components can cause fatal injury.**

- ▶ Only allow work on the electrical system to be carried out by qualified electrical engineers.
- ▶ In the event of damage to the insulation, immediately shut off the power supply and initiate a repair.
- ▶ Before starting work on active parts of the electrical system or equipment, ensure that it is completely powered down and cannot be switched on again.

#### **Before starting disassembly:**

- ▶ Disconnect all power supplies to the machine and ensure that it cannot be reconnected
- ▶ Disassemble assemblies and components, observing any local environmental protection regulations

## 9 Disposal

At the end of its service life, the machine must be disassembled and disposed of in accordance with environmental protection requirements.

- ▶ If no return or disposal agreement has been concluded, dispose of the components in a recycling facility after they have been properly disassembled.
- ▶ Scrap metal parts.



## 10 Spare part and wear part

Spare part must meet the manufacturer's technical specifications. This is always ensured if original Spare part are used.

### 10.1 Spare part and wear part type XP - TP – SP

Spare part and wear part of the product Parallel-Indexer are basically order specific. To accelerate the order process of the Spare part and wear part, we need the following information which is located on the rating plate: Serial number of the machine.



Figure 35 Example Rating plate

Position (1) Serial number



**10.1.1 Spare parts and wear part list type XP030-130**

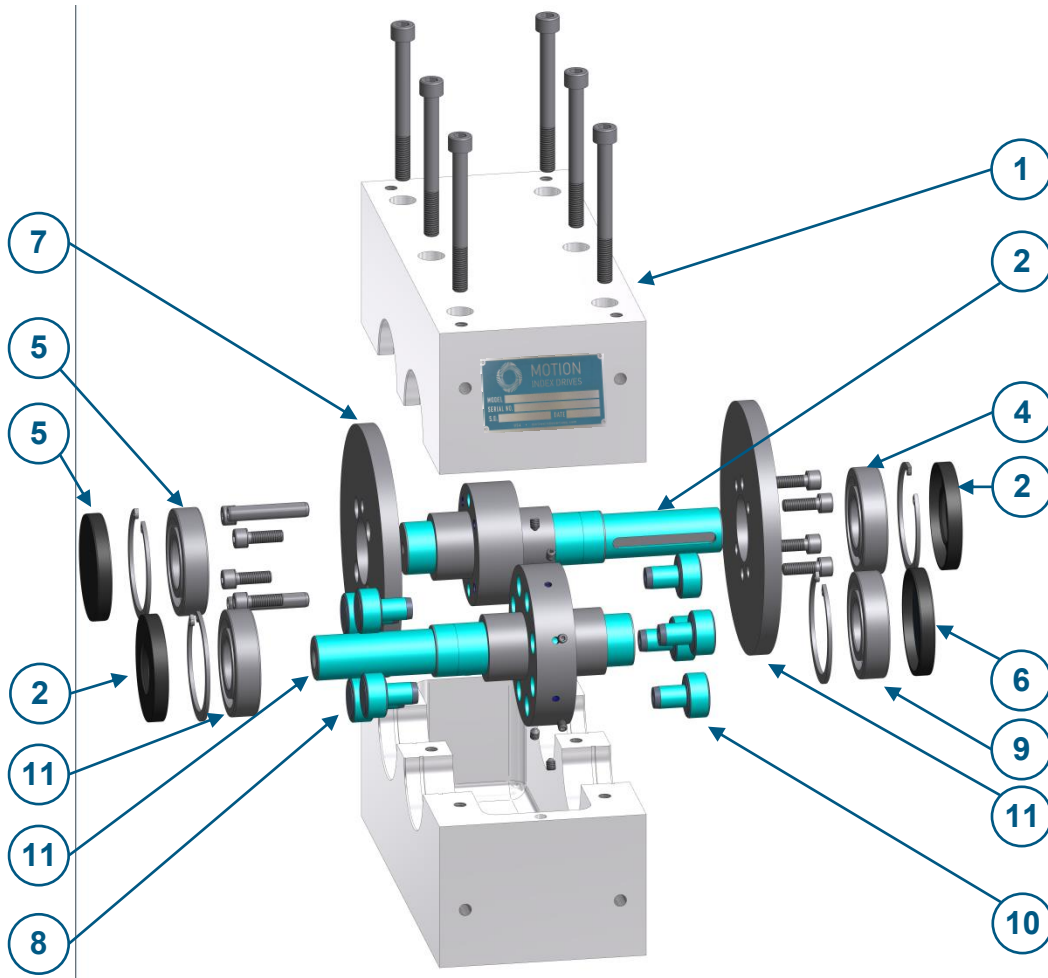

Fig. 36 Detail spare parts and wear parts XP030-130

Item	Number	Designation	Gear type						
			XP030	XP040	XP050	XP065	XP080	XP105	XP130
1	1	Housing	*	*	*	*	*	*	*
2	1	Input shaft	*	*	*	*	*	*	*
3	1	Star wheel	*	*	*	*	*	*	*
4	n*	Cam follower	*	*	*	*	*	*	*
5	n*	Pin	*	*	*	*	*	*	*
6	1	Cam set	*	*	*	*	*	*	*
7	2	Shaft seal	*	*	*	*	*	*	*
8	2	Sealing cap	*	*	*	*	*	*	*
9	2	Bearing	*	*	*	*	*	*	*
10	2	Bearing	*	*	*	*	*	*	*
11	2	Eccentric ring	-	-	-	-	-	-	-
12	2	Input flange	-	-	-	-	-	-	-
13	2	Output flange	-	-	-	-	-	-	-
14	1	Assembly set / NBR	-	310165	310669	311281	311282	310665	310666
15	1	Assembly set / Viton	-	-	-	-	311651	-	-

\*Product specific Contact Motion Index Drives



**10.1.2 Spare parts and wear part list type XP165-250**

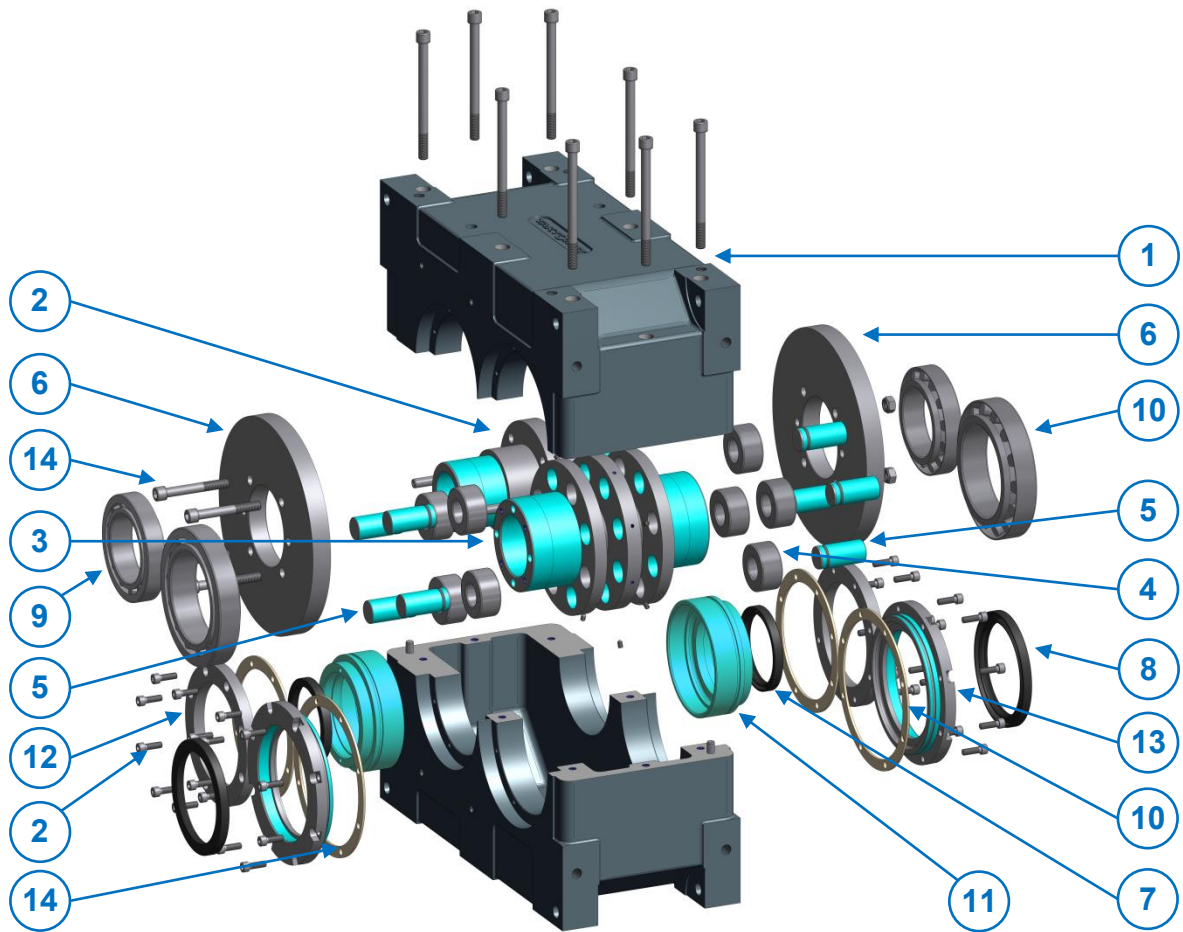

Fig. 37 Detail spare parts and wear parts XP165-250

Item	Number	Designation	Gear type		
			XP165	XP200	XP250
1	1	Housing *		*	*
2	1	Input shaft *		*	*
3	1	Star wheel *		*	*
4	n*	Cam follower *		*	*
5	n*	Pin *		*	*
6	1	Cam set *		*	*
7	2	Shaft seal 301393		302055	300555
8	2	Shaft seal 301079		300555	300554
9	2	Bearing 301391		301407	301407
10	2	Bearing 301392		301406	300301
11	2	Eccentric ring 301382		301399	300773
12	2	Input flange 301383		301400	301371
13	2	Output flange 301384		301401	300776
14	4	Shim *		*	*
15	1	Assembly set / NBR		310165	310669
16	1	Assembly set / Viton		-	-

\*Product specific

Contact **TAKTOMAT!**

**10.1.3 Spare parts and wear part list type TP040-160**

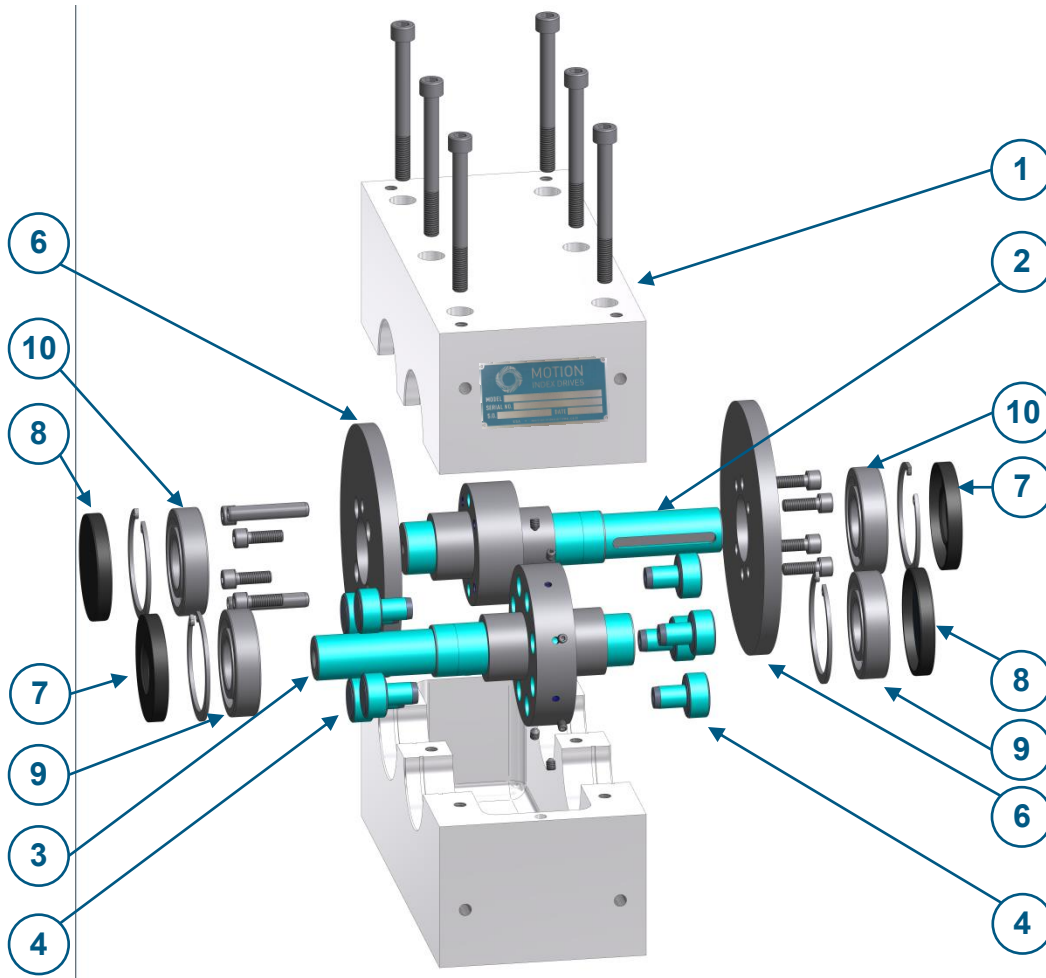

Fig. 38 Detail spare parts and wear parts TP040-160

Item	Number	Designation	Gear type						
			TP040	TP063	TP080	TP100	TP125	TP160	
1	1	Housing	*	*	*	*	*	*	
2	1	Input shaft	*	*	*	*	*	*	
3	1	Star wheel	*	*	*	*	*	*	
4	n*	Cam follower	*	*	*	*	*	*	
5	n*	Pin	-	-	-	-	-	-	
6	1	Cam set	*	*	*	*	*	*	
7	2	Shaft seal	*	*	*	*	*	*	
8	2	Sealing cap	*	*	*	*	*	*	
9	2	Bearing	*	*	*	*	*	*	
10	2	Bearing	*	*	*	*	*	*	
11	2	Eccentric ring	-	-	-	-	-	-	
12	2	Input flange	-	-	-	-	-	-	
13	2	Output flange	-	-	-	-	-	-	
14	1	Assembly set / NBR		310165	310669	311281	311282	310665	
15	1	Assembly set / Viton		-	-	-	311651	-	

\*Product specific  
Contact **TAKTOMAT!**



10.1.4 Spare parts and wear part list type SP105

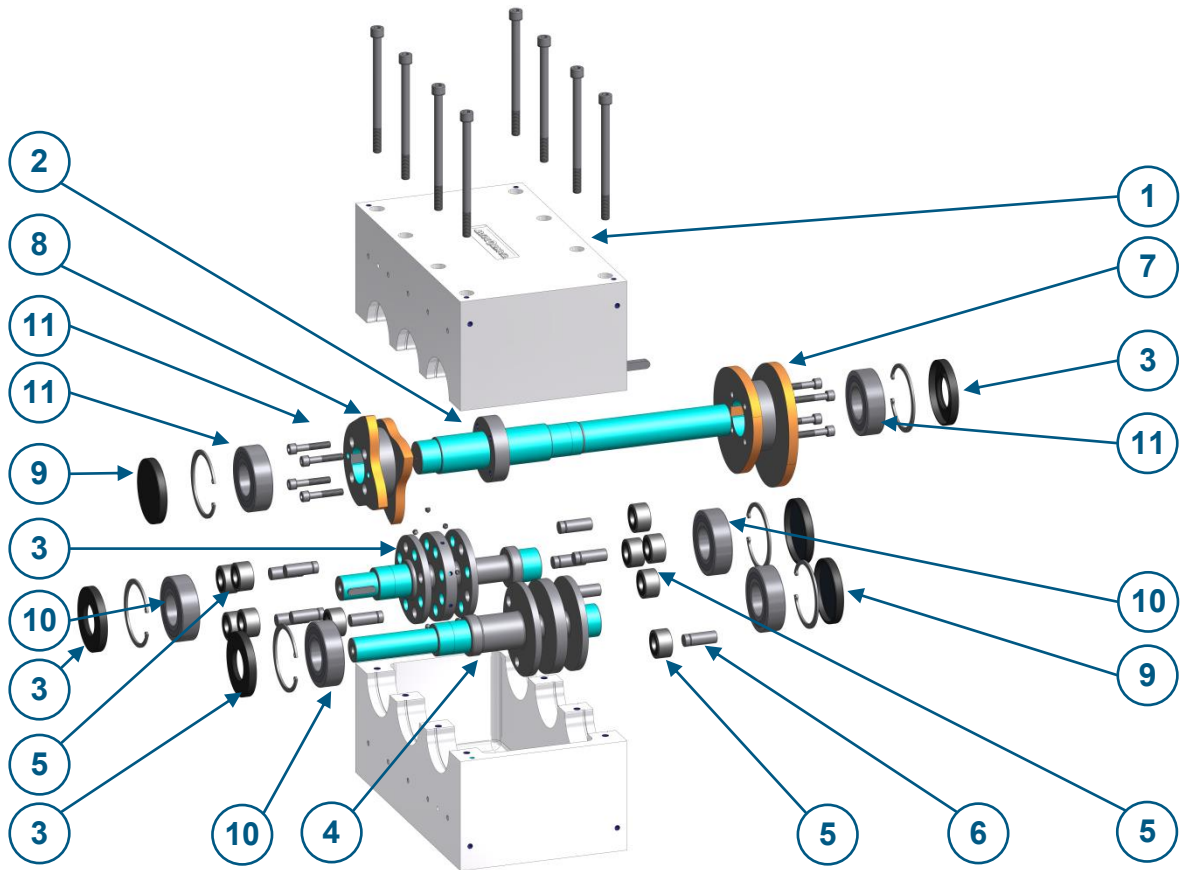

Fig. 39 Detail spare parts and wear parts SP105

Item	Number	Designation	Gear type
		<b>SP105</b>	
1	1	Housing	324153
2	1	Input shaft	*
3	1	Output shaft	*
4	1	Star wheel	*
5	n*	Cam follower	*
6	n*	Pin	*
7	1	Cam set	*
8	1	Cam set	*
9	3	Sealing cap	304323
10	3	Shaft seal	304264
11	4	Bearing	309088
12	2	Bearing	309088
13	2	Eccentric ring	-
14	2	Input flange	-
15	2	Output flange	-
16	1	Assembly set / NBR	-
17	1	Assembly set / Viton	-

\*Product specific

Contact **TAKTOMAT!**



## 11 Annex

### 11.1 Safety data sheets

No.	Designation
1	EP 2 Grease Data Sheet HI
2	MOBILGEAR 600 XP 460 SAFETY DATA SHEET