



MOTION INDEX DRIVES

ADDITIONAL PRODUCTS & SERVICES



Trunnion Solutions

Motion can provide in addition to the trunnion headstock drive a complete trunnion assembly. The complete trunnion solutions we provide utilize our standard, high-reliability and precise indexing equipment with custom weldments that exceed our customers' expectations.

Features

- Headstock (RT, TR, and TMF Series)
- Tailstock (bearing assembly or thru-hole bearing housing)
- Center Frame (custom length and weldment design)
- Optional Controls Drive for Motor
- Optional Micarta isolation kits
- Customer specified paint finish on all stationary components
- Black oxide head and tailstock flanges

Benefits

- Purchase multiple components from one source reducing purchasing management time
- Reduce project management time by utilizing Motion to order necessary components
- Minimize your design time by utilizing our standard designs that are readily available
- Minimize assembly time while decreasing your required man hours on your projects
- We will mount customer supplied motors and other
- Minimize shipping and handling cost by purchasing from one source



Rotary Index Table Tooling Frames

Tooling frames and weldments can be manufactured to our customers print. These can be delivered complete with our index drives, to allow for a simpler installation. Weldments can be manufactured to your drawings and can be offered upon receipt of the drawing for quoting.

Features

- Available in extremely low profile designs
- A-Frame, H-Frame welded structures to meet ergonomic load requirements
- FEA studies completed by Motion based on your tooling/fixture loads
- Reduce mass moment of inertia by utilizing our design experience
- Machine enamel, Epoxy or Powder Coating to customers color spec.
- Frames manufactured to allow customer to simply bolt on tooling and fixtures

Benefits

- Purchase multiple components from one source reducing purchasing management time
- Reduce project management time by utilizing Motion to order necessary components
- Minimize your design time by utilizing our standard designs that are readily available
- Minimize assembly time while decreasing your required man hours on your projects
- We will mount customer supplied motors and other
- Minimize shipping and handling cost by purchasing from one source

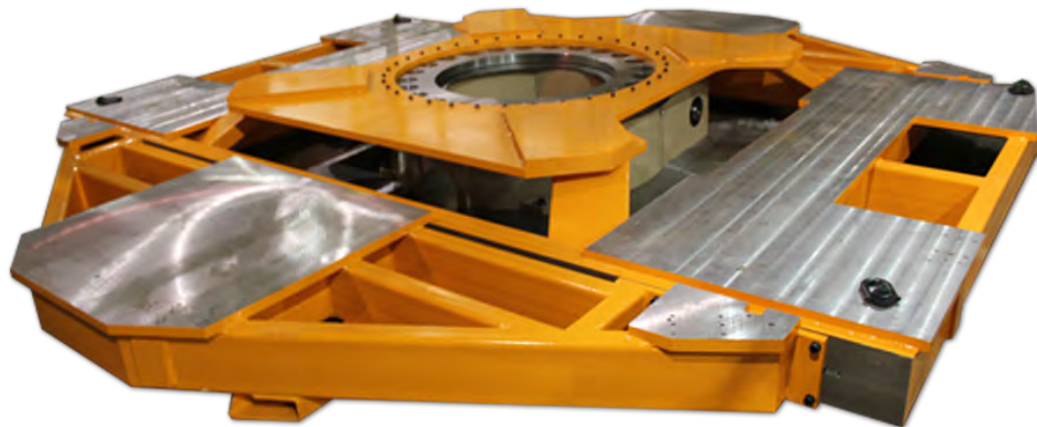

Motion Index Drives can supply any dial plate required, made from nearly any material, including steel, aluminum, and plastics. Simply specify the thickness, diameter, material and special coatings (if required) of the plate and we will supply this with the index drive complete. We can also have the dial plate machined to your drawing, allowing for less work for our customers.

Features

- Round, rectangle, triangle or custom shape
- Machining to your print
- Special tolerances
- Bushings
- Thread inserts
- Anodizing
- Nickel plating
- Stainless steel
- Black oxide
- Teflon

Benefits

- Purchase multiple components from one source reducing purchasing management time
- Reduce project management time by utilizing Motion to order necessary components
- Minimize your design time by utilizing our standard designs that are readily available
- Minimize assembly time while decreasing your required man hours on your projects
- We will mount customer supplied motors and other
- Minimize shipping and handling cost by purchasing from one source

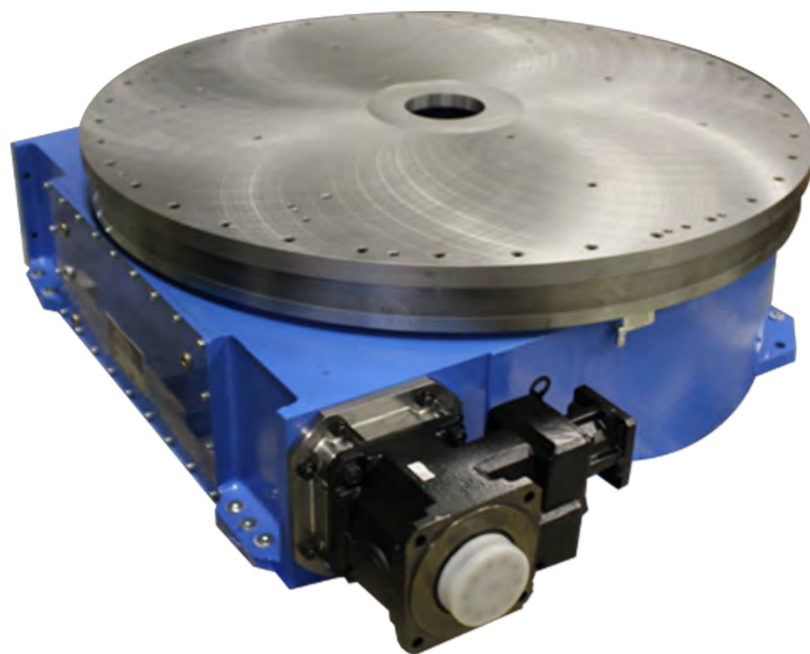

Machine Bases

Machine bases can be manufactured to our customers print or we can recommend a standard base to fit. These can be delivered complete with our index drives, to allow for a simpler installation. Bases can be manufactured to your drawings and can be offered upon receipt of the drawing for quoting.

Features

- Many different hollow structural tubular frame choice
- Aluminum Anodized and Stainless Steel Top Plates
- Steel top plates
- Nickel, Black Oxide or other finishing available
- Surface ground for precision
- Leveling and tie down foot pads
- Casters for mobility if required
- Machine enamel, Epoxy or Powder Coating to customers color spec.

Benefits

- Purchase multiple components from one source reducing purchasing management time
- Reduce project management time by utilizing Motion to order necessary components
- Minimize your design time by utilizing our standard designs that are readily available
- Minimize assembly time while decreasing your required man hours on your projects
- We will mount customer supplied motors and other
- Minimize shipping and handling cost by purchasing from one source

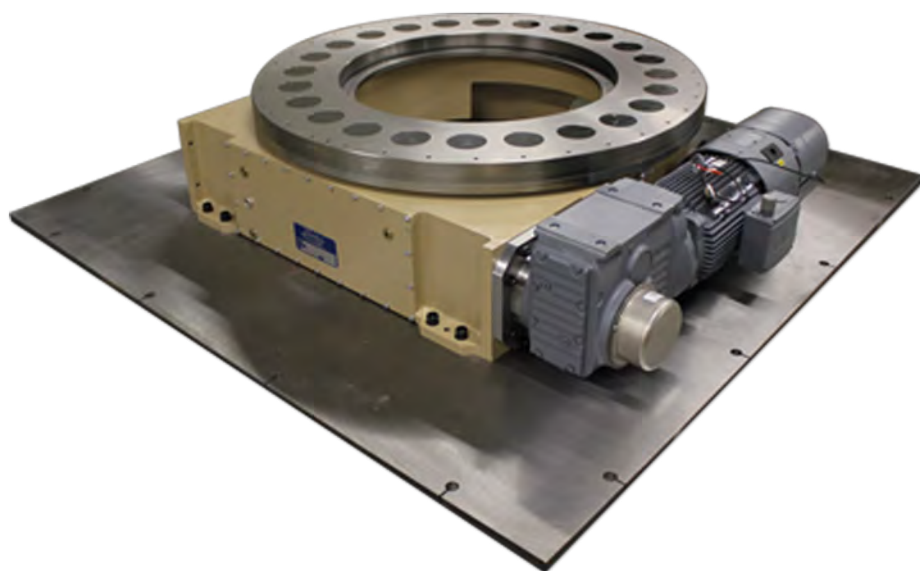

TripleDex Indexer

Motion's Multidex Indexer solution provides one large base rotary index table with smaller satellite indexers. This allows the tooling or part to be rotated on one end of the work cell while the other end can be safely interfaced or rotated to allow for different access. The standard units include a base rotary index table with 2, 3 or 4 satellite indexers. The base and satellite indexers can have either a fixed or flexible number of stations. Multidex units come complete with baseplate or base frame ready to be mounted in your cell.

Features

- Utilizes high precision TMF or RT series rotary index tables
- Complete with high voltage slip ring to power satellite indexers
- Large through hole on base indexer in the housing and in the center
- Through holes enable you to run utilities at ground level
- Absolute encoder on satellite indexer input shaft for high accuracy
- Special sealing on all indexers for harsh environments

Benefits

- Purchase multiple components from one source reducing purchasing management time
- Reduce project management time by utilizing Motion to order necessary components
- Minimize your design time by utilizing our standard designs that are readily available
- Minimize assembly time while decreasing your required man hours on your projects
- We will mount customer supplied motors and other
- Minimize shipping and handling cost by purchasing from one source



Other Complimentary Components

Slip Rings / Rotary Unions

Our MSR series rotary union / slip ring assembly can be manufactured to our customer's specification. These can be delivered complete with our index drives, to allow for a simpler installation.



Features

- Low and high voltage capabilities from 24 VDC up to 600 VAC 3 phase
- Single circuit up to 96 circuits
- Multiple or single air or fluid ports ranging in size 1/8" to 1 1/2" dia.
- Device Net, Profibus, USB, CanBus and ProfiNet compatible
- Rotary union is capable to transmit air or fluids
- Special connections available for data and electrical
- Custom tail connections with customer specified lengths

Benefits

- Purchase multiple components from one source reducing purchasing management time
- Reduce project management time by utilizing Motion to order necessary components
- Minimize your design time by utilizing our standard designs that are readily available
- Minimize assembly time while decreasing your required man hours on your projects
- We will mount customer supplied motors and other
- Minimize shipping and handling cost by purchasing from the source

Switch Packages

- Encoders
- Proximity Switches
- Mechanical Switches

Tooling and Accessories

- Adapter Plates
- Dial Plates
- Base Plates
- Trunnion Riser Weldments
- Pillow Blocks for Trunnion Mounting
- Mechanical Safety Lock-Outs
- Satellite Index Drive Machines
- Partially Built Indexer Cells

Motors and Reducers

- Explosion-Proof Motors
- Servo Motors
- Stainless Steel Motors

Low-Backlash Gear Reducers

Custom Cams

- Custom Auxiliary Cam operations
- Custom Cams to implement into existing operation

Custom Coatings

- Powder Coatings
- Nickel Plating
- Anodizing
- Stainless Steel
- Black Oxide

Controls

- VFD's
- Servo Drives
- Complete Integrated Index Drive Control Panel



Precision Indexing Since 1970

Motion Index Drives, Inc. has built a tradition of excellence in the engineering, designing and manufacturing of cam-driven indexers. This tradition has translated into a reputation for the most robust and reliable indexers available: a reputation we will continue to build upon.

At Motion Index Drives, our goal is to build the highest quality indexers so that you may manufacture the highest quality product possible. Take advantage of this opportunity to peruse the information in this catalog and see why our indexers are not only more precise than our competitors, but also have higher load capacities, consume less energy and last years longer.

Know that whatever automation challenge you may be facing, Motion Index Drives' engineers can produce a solution to complete the task. Whether it is the MEDEX line (clean room ready), our patented NANO Indexer Technology (producing the world's most accurate barrel cam indexers), or an innovative new solution that emerges for your process, Motion Index Drives is here to help.

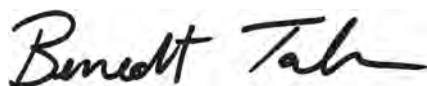

Benedict Talan
President

Table of Contents

Foreword	1
A History of Motion Index Drives	3
Inertia Calculations	4
Rotary Tables	
TMF Series	5
RT Series	12
TT Series	45
Ring Index Drives	
TSR Series	55
Parallel Index Drives	
XP Series	59
TP Series	81
Right Angle Drives	
TG Series	95
Precision Link Conveyor	
LF/LFS Series	107
LZ Series	119
Pick and Place Units	120
Lift and Carry Systems	123
Flexible Positioning Systems	
TR Series	124
DR-TR Series	128
Additional Products and Services	
Trunnion Solutions	133
Tooling Frames	134
Dial Plates	135
Machine Bases	136
TripleDex Indexer	137
Accessories	138
Services	139
NANO Technology	140
Clean Room Solutions	141

A History of Motion Index Drives

OUR START

In 1970, brothers Al and Bob Sievers set out to change the future of manufacturing automation. Originally located at 6100 East Davidson in Detroit, Michigan, Motion Manufacturing developed the cornerstone of Motion Index Drives today, producing innovative, custom solutions to solve the high demands of the growing fields of industrial automation. In a short time the I Series Rotary Index Table became a staple in various industries, running continuously for several million cycles in the harshest industries without a minute of downtime. Building on the success of the I Series, tables of varying scales and configurations were constructed for new applications and Motion Manufacturing continued to expand. As new technologies developed, new devices were required for automation processes. Motion Manufacturing developed various projects alongside its known rotary tables. Parallel indexers, right angle drives, lift and carry systems, and lift and rotate machines were developed to meet the growing needs of existing and new clients. By the early 2000s Motion Manufacturing had changed its name to Motion Index Drives, Inc., and found a new home in Troy, MI. Along with a new name and home, Motion Index Drives Inc. had expanded their reach globally.

Ever evolving, Motion Index Drives Inc. developed the NANO Indexer Technology which secured the rights to the world's most accurate cam indexers. Developments in indexing technology have led to the inclusion of our indexers in new industries over the years. Motion Index Drives' products now drive processes for microelectronic assembly, medical equipment manufacturing, food and pharmaceutical processing, consumer goods manufacturing and many other industries.

OUR FUTURE

Throughout the company's history, the driving force behind Motion Index Drives Inc. has been creating innovative solutions to develop the best indexing devices on the market and making automation simpler and more efficient. By living up to this philosophy, we will continue to improve and develop new products, furthering the successful growth of our company and adding to a remarkable story that grew from humble beginnings.

INERTIA CALCULATIONS

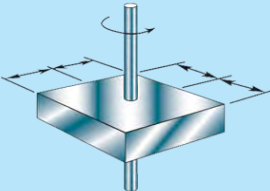
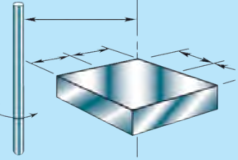
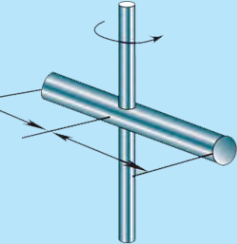
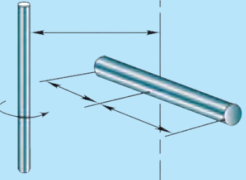
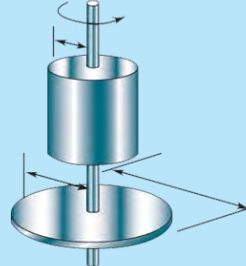
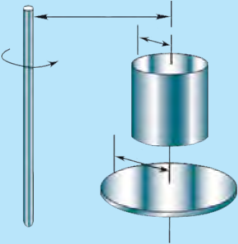
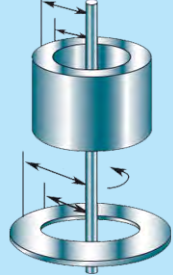
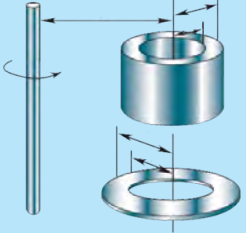
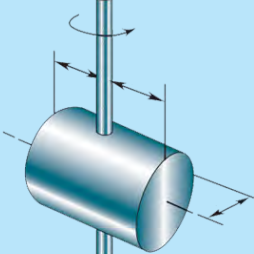
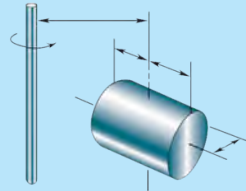
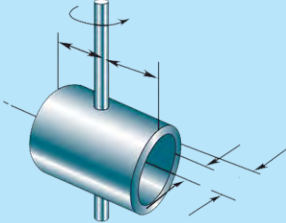
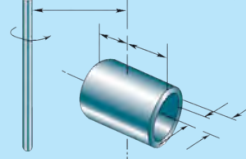
Body With Central Axis of Rotation	K^2	Body With Offset Axis of Rotation	K^2
Rectangular prism or plate rotating about its central perpendicular axis 	$\frac{A^2 + B^2}{3}$	Rectangular prism or plate rotating about a perpendicular offset axis 	$\frac{A^2 + B^2}{3} + H^2$
Long thin rod of any cross section rotating about its central perpendicular axis 	$\frac{L^2}{3}$	Long thin rod of any cross section rotating about a perpendicular offset axis 	$\frac{L^2}{3} + H^2$
Solid cylinder or disc rotating about its own axis 	$\frac{R^2}{2}$ or $\frac{D^2}{8}$	Solid cylinder or disc rotating about an offset parallel axis 	$\frac{R^2}{2} + H^2$
Hollow cylinder or flat ring rotating about its own axis 	$\frac{R^2 + r^2}{2}$	Hollow cylinder or flat ring rotating about an offset parallel axis 	$\frac{R^2 + r^2}{2} + H^2$
Solid cylinder rotating about its diameter at mid-length 	$\frac{L^2}{3} + \frac{R^2}{4}$	Solid cylinder rotating about an offset axis parallel to its diameter 	$\frac{L^2}{3} + \frac{R^2}{4} + H^2$
Hollow cylinder rotating about its diameter at mid-length 	$\frac{L^2}{3} + \frac{R^2 + r^2}{4}$	Hollow cylinder rotating about an offset axis parallel to its diameter 	$\frac{L^2}{3} + \frac{R^2 + r^2}{4} + H^2$



MOTION INDEX DRIVES

SERVO/PROGRAMMABLE TABLES
TMF Series

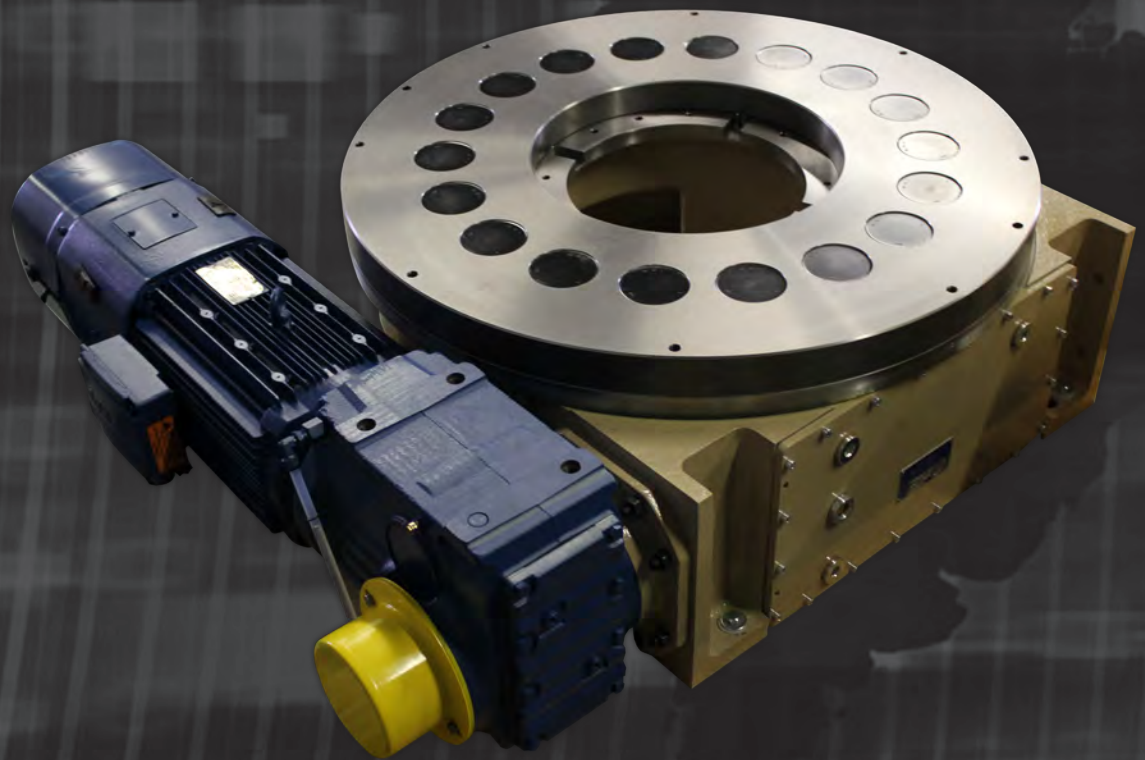



MOTION INDEX DRIVES

The New Standard for 100% Programmable/ Servo Indexing

The TMF Series of index drives was engineered to satisfy the needs of the 21st century industrial manufacturing environment: fast, strong, reliable, high quality and cost effective.

The TMF Series features a cast housing that is compact and has all the characteristics a manufacturer looks for: large center thru-hole for running utilities and mounting equipment; very low profile to eliminate the need for large A-frame type tooling or operator riser platforms; and a large rotating diameter for increased mounting surface.

In order to increase the strength of the index table, the TMF Series was designed to be a completely flexible solution. This allows for a minimum of 4 oversized cam followers to be engaged with the barrel cam at all times. The indexer is driven directly via a gear motor that can utilize either an AC motor with encoder or servo. Both options provide very high accuracy (less than 10 arc seconds) and allow for the indexer to be driven via a dedicated or robot drive.

Loading capabilities are multiplied significantly in this line of indexers through the design of the barrel cam and cam followers. This unique design allows for unprecedented inertial load capability. The TMF Series also utilizes the same high quality bearing configuration as our standard index drives to ensure high mass loading capabilities.



Programmable Index Drives

The rotary index table transforms a constant input drive motion into a constant output drive motion. The drive motion occurs by means of a hardened and high-accuracy constant lead barrel cam. The use of mathematical laws of motion along with a properly programmed motor profile guarantee a soft, shock proof, and jerk free movement that has been optimally designed for its intended purpose. The design allows for accurate and secure mounting to the output dial. The preload of the cam to the cam followers in dwell ensures the top dial is backlash free. No additional adjustment of the output dial is necessary.

The power to rotate the index drive is provided either by means of a three phase AC motor with encoder, coupled to a gear reducer, or a servo motor coupled to a gear reducer. The gear reducer is connected to the input shaft which is firmly connected to the internal barrel cam with no further internal gearing. The barrel cam in turn rotates the top dial through the cam followers with a zero backlash internal design. The output dial is mounted to a wire bearing assembly (4 point contact bearing), which is preloaded to eliminate any runout. The index drive is completely sealed to eliminate intrusion from foreign particulate.

Advantages for design engineers and special machine builders

- Large center thru-hole which is large enough to feed entire shafts through, and not just small wiring looms
- Dowel holes in housing and in output flange
- Recessed center column. No obstruction. Lengthened and machined to customer requirements
- Simultaneously rotating input shaft extension. Optional synchronization of other mechanical modules

Allowance for individual customer requirements

- Choice of drive
- Reinforced output flange bearing for higher tilting moment
- Optional friction clutch on drive
- Custom specified color at no extra charge technical

Technical benefits for users

- High reliability and long service life
- Robust method of construction
- Hardened cams: smaller sizes for higher load factors
- Cam followers and roller bearings fully immersed in oil bath
- Cam followers are extractable from top

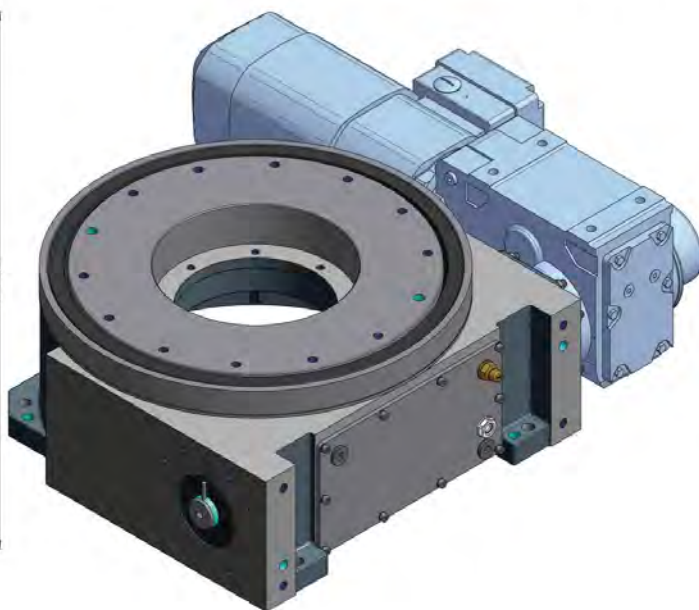
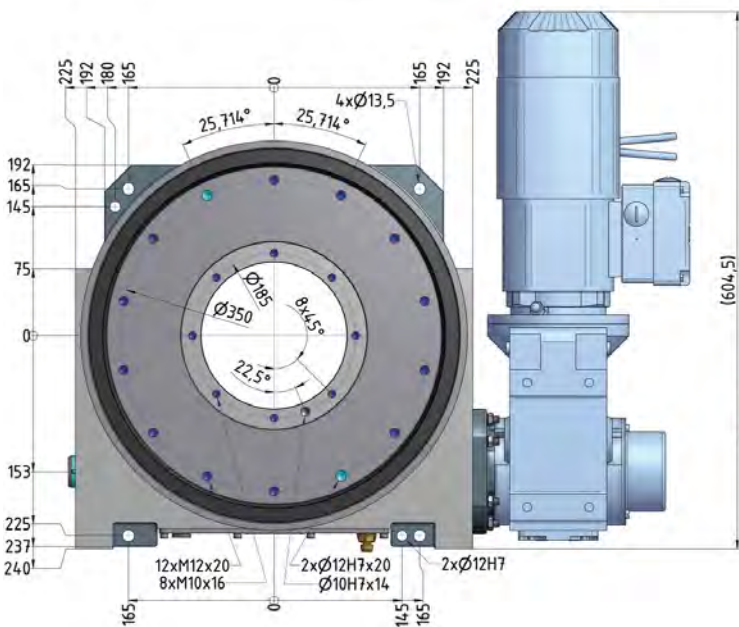
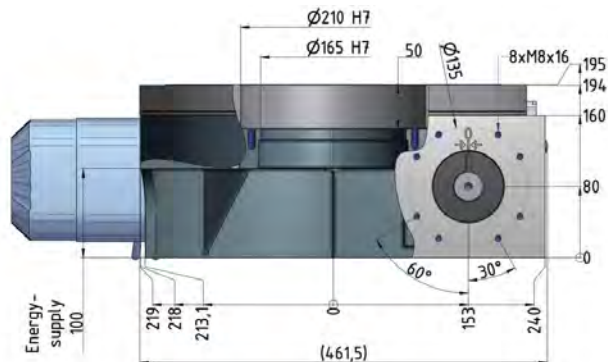
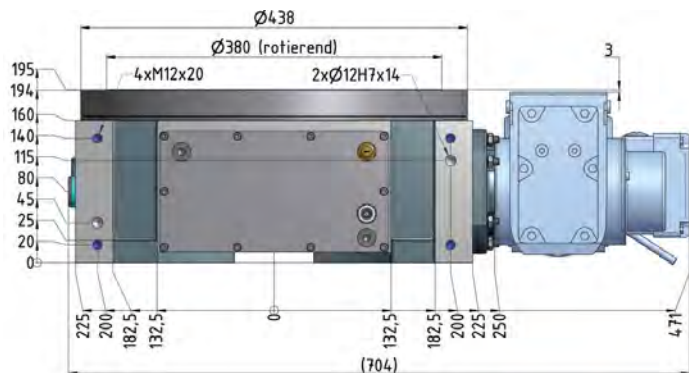

TMF1000

Dimensions	
Diameter output flange	380 mm
Overall height (mounting surface dial)	195 mm
Center thru-hole	165 mm
Maximum recommended swing diameter	3000 mm
Weight	130 kg
Load Ratings	
Axial	213,000 N
Radial	100,000 N
Tilting	19,000 Nm

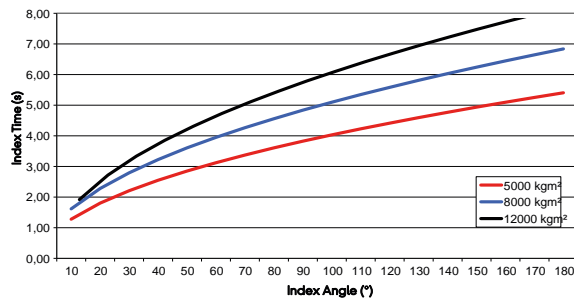

*Please note, the load chart shown can be affected by user programming required, including acceleration rates, deceleration rates, velocity profiles, e-stop times required, etc. For validation of sizing, please verify all loading with Motion Index Drives, Inc.

The dimensions shown here are the standard dimensions. The output flange, central column, housing and input shafts can be machined to your specifications. The central column can also be designed as a flange. Should you wish to drill a additional holes, please consult us with regard to acceptable drilling depth.



The dimensions for the gearmotor may change based on the gearmotor size and options required for the application.

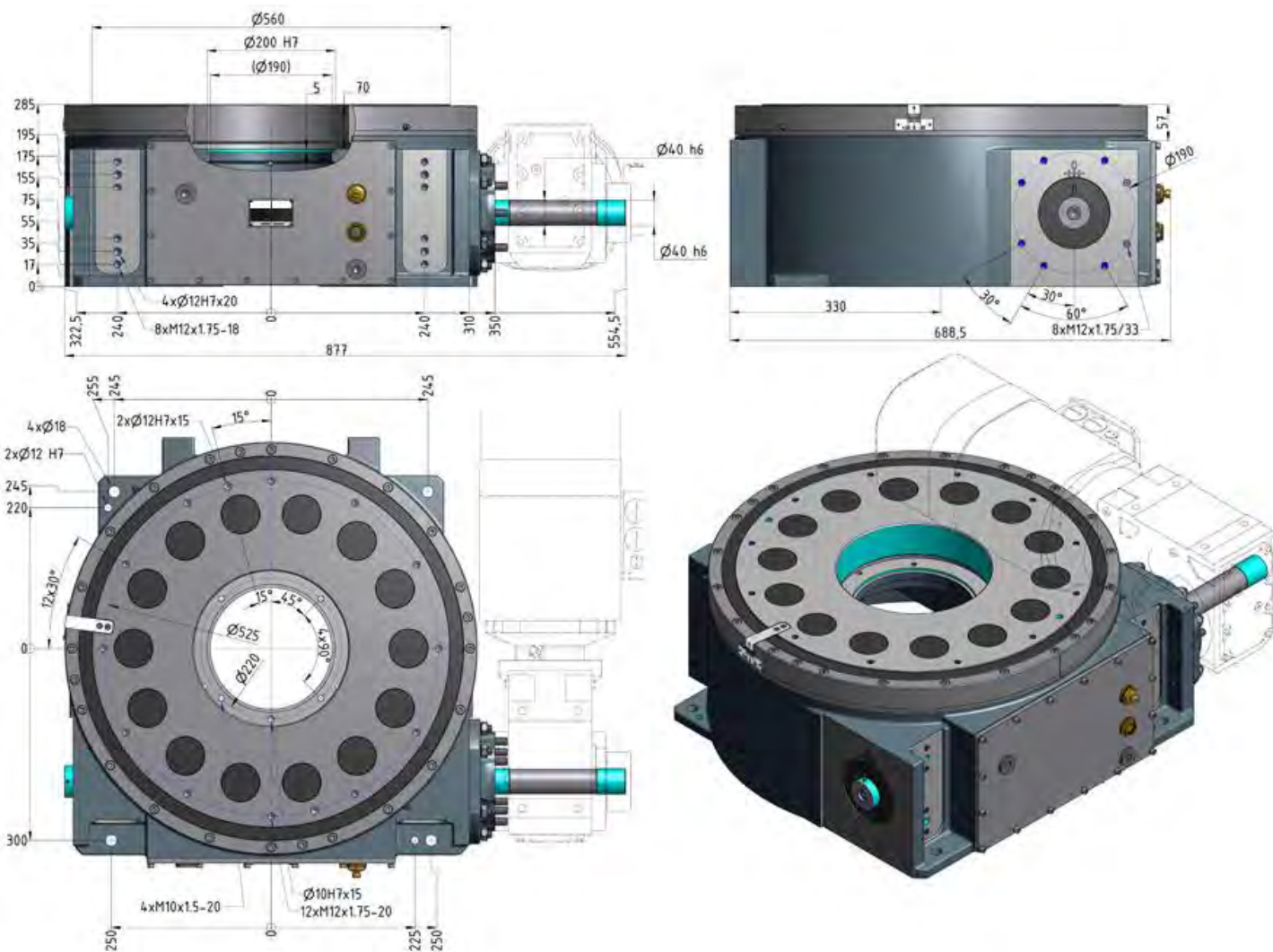

TMF2000

Dimensions	
Diameter output flange	560 mm
Overall height (mounting surface dial)	285 mm
Center thru-hole	190 mm
Maximum recommended swing diameter	3,500 mm
Weight	440 kg
Load Ratings	
Axial	753,000 N
Radial	353,000 N
Tilting	207,500 Nm

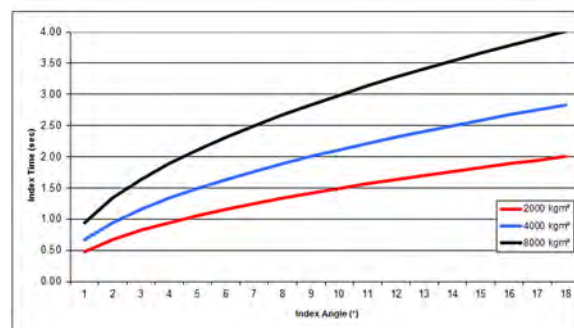

*Please note, the load chart shown can be affected by user programming required, including acceleration rates, deceleration rates, velocity profiles, e-stop times required, etc. For validation of sizing, please verify all loading with Motion Index Drives, Inc.

The dimensions shown here are the standard dimensions. The output flange, central column, housing and input shafts can be machined to your specifications. The central column can also be designed as a flange. Should you wish to drill a dditional holes, please consult us with regard to acceptable drilling depth.



The dimensions for the gearmotor may change based on the gearmotor size and options required for the application.

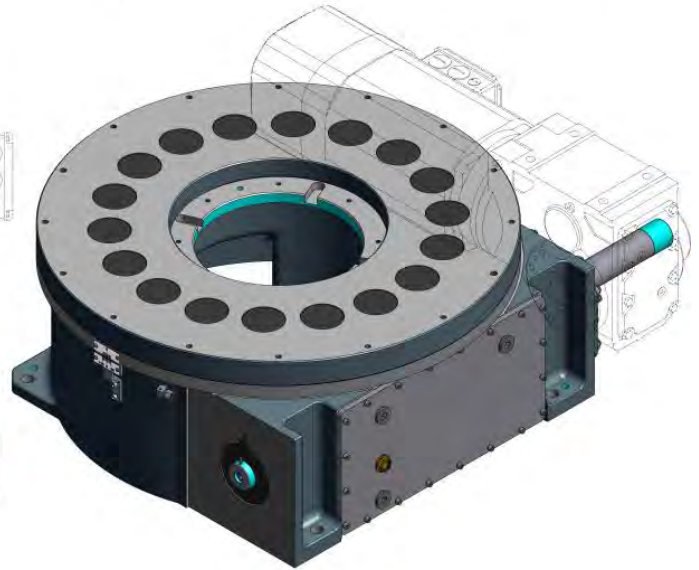
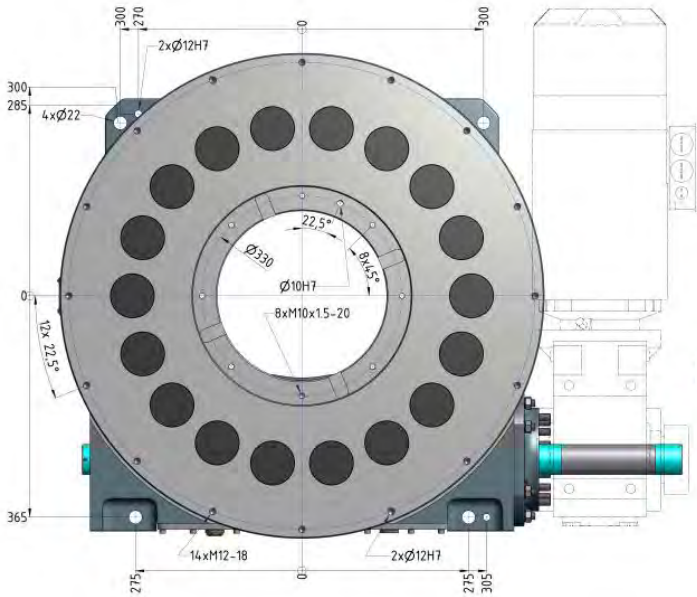
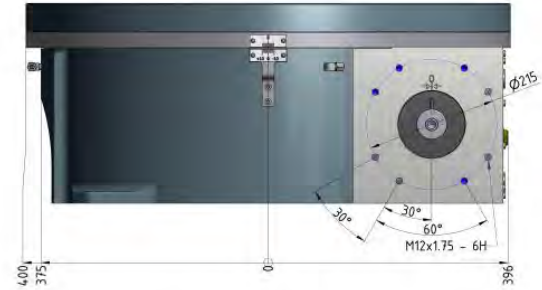
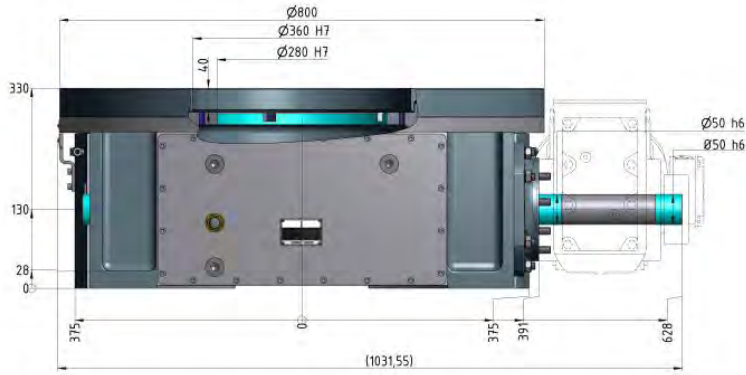

TMF3000

Dimensions	
Diameter output flange	800 mm
Overall height (mounting surface dial)	330 mm
Center thru-hole	280 mm
Maximum recommended swing diameter	4,500 mm
Weight	520 kg
Load Ratings	
Axial	965,000 N
Radial	454,000 N
Tilting	357,000 Nm

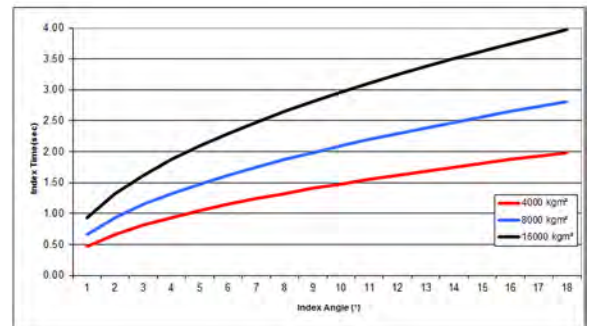

*Please note, the load chart shown can be affected by user programming required, including acceleration rates, deceleration rates, velocity profiles, e-stop times required, etc. For validation of sizing, please verify all loading with Motion Index Drives, Inc.

The dimensions shown here are the standard dimensions. The output flange, central column, housing and input shafts can be machined to your specifications. The central column can also be designed as a flange. Should you wish to drill a dditional holes, please consult us with regard to acceptable drilling depth.



The dimensions for the gearmotor may change based on the gearmotor size and options required for the application.

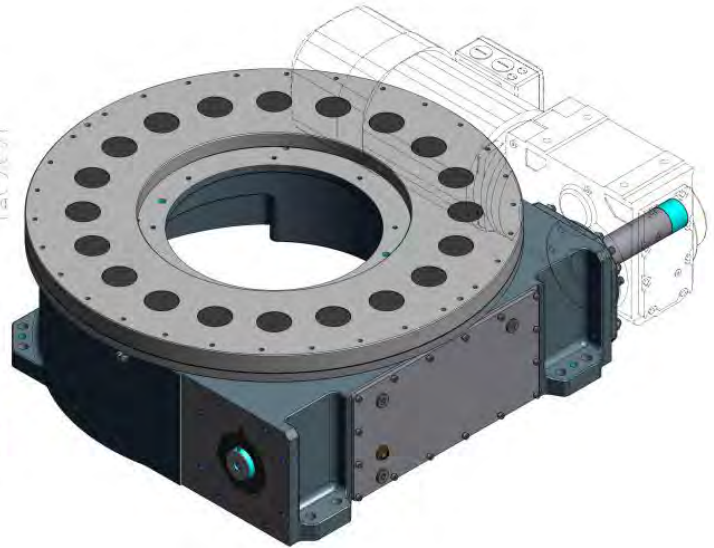
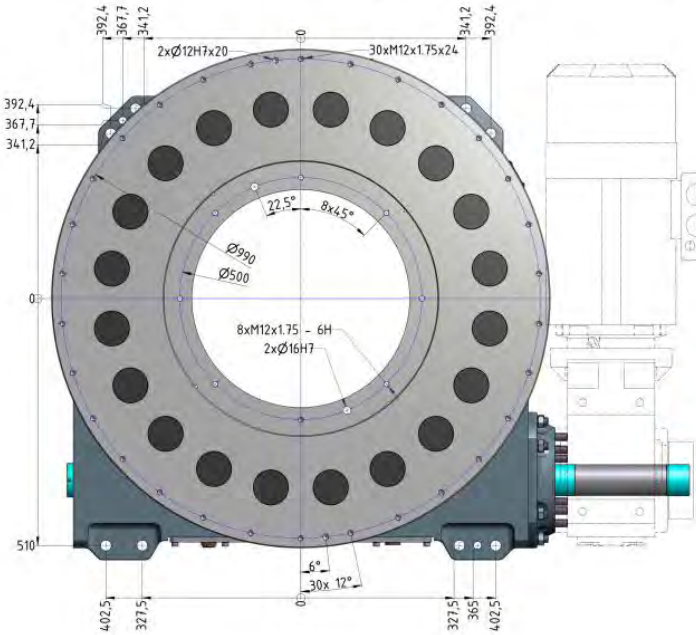
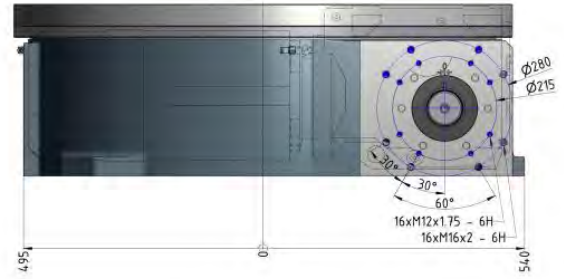
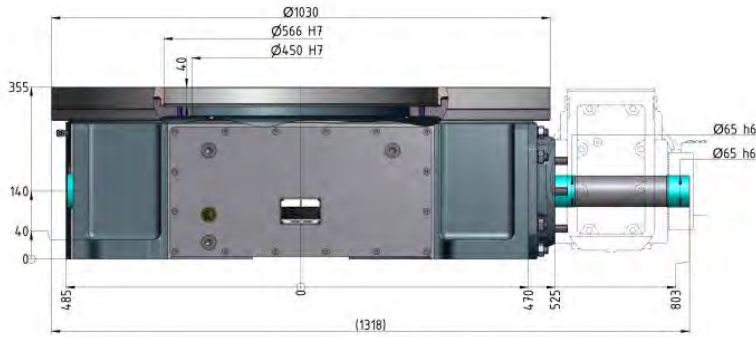

TMF4000

Dimensions	
Diameter output flange	1,050 mm
Overall height (mounting surface dial)	365mm
Center thru-hole	450 mm
Maximum recommended swing diameter	6,500 mm
Weight	910 kg
Load Ratings	
Axial	1,185,000 N
Radial	590,000 N
Tilting	525,000 Nm

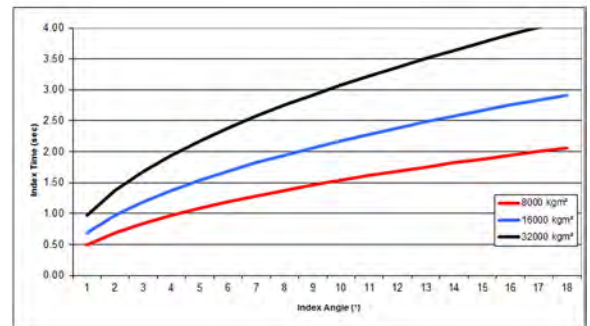

*Please note, the load chart shown can be affected by user programming required, including acceleration rates, deceleration rates, velocity profiles, e-stop times required, etc. For validation of sizing, please verify all loading with Motion Index Drives, Inc.

The dimensions shown here are the standard dimensions. The output flange, central column, housing and input shafts can be machined to your specifications. The central column can also be designed as a flange. Should you wish to drill a additional holes, please consult us with regard to acceptable drilling depth.



The dimensions for the gearmotor may change based on the gearmotor size and options required for the application.

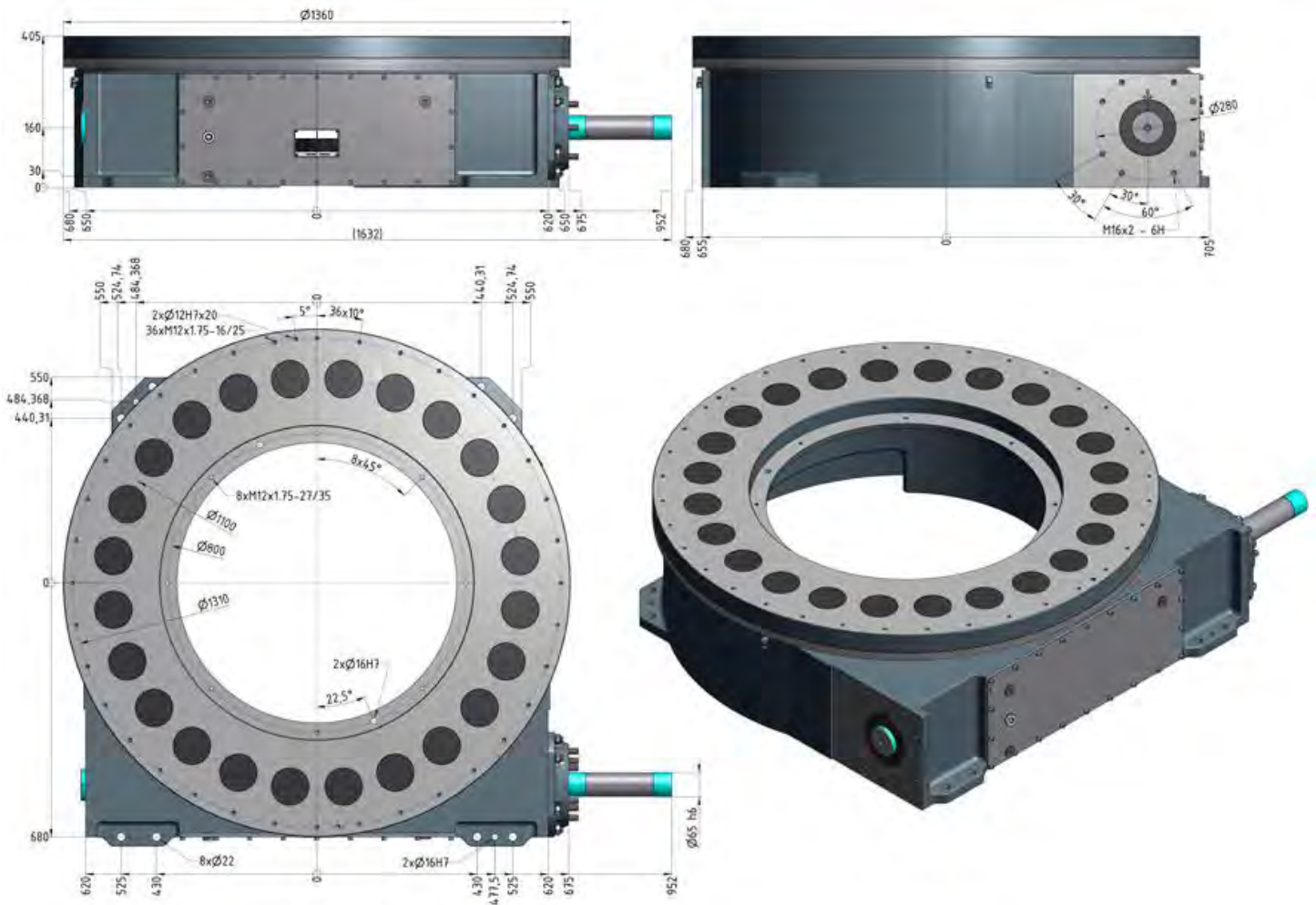

TMF5000

Dimensions	
Diameter output flange	1,360 mm
Overall height (mounting surface dial)	405 mm
Center thru-hole	750 mm
Maximum recommended swing diameter	10,000 mm
Weight	1,470 kg
Load Ratings	
Axial	1,649,000 N
Radial	776,000 N
Tilting	1,063,500 Nm

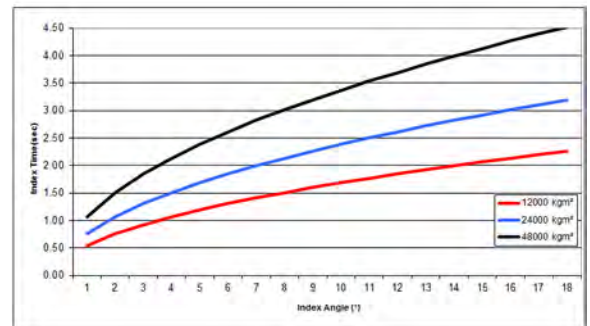

*Please note, the load chart shown can be affected by user programming required, including acceleration rates, deceleration rates, velocity profiles, e-stop times required, etc. For validation of sizing, please verify all loading with Motion Index Drives, Inc.

The dimensions shown here are the standard dimensions. The output flange, central column, housing and input shafts can be machined to your specifications. The central column can also be designed as a flange. Should you wish to drill a additional holes, please consult us with regard to acceptable drilling depth.



The dimensions for the gearmotor may change based on the gearmotor size and options required for the application.

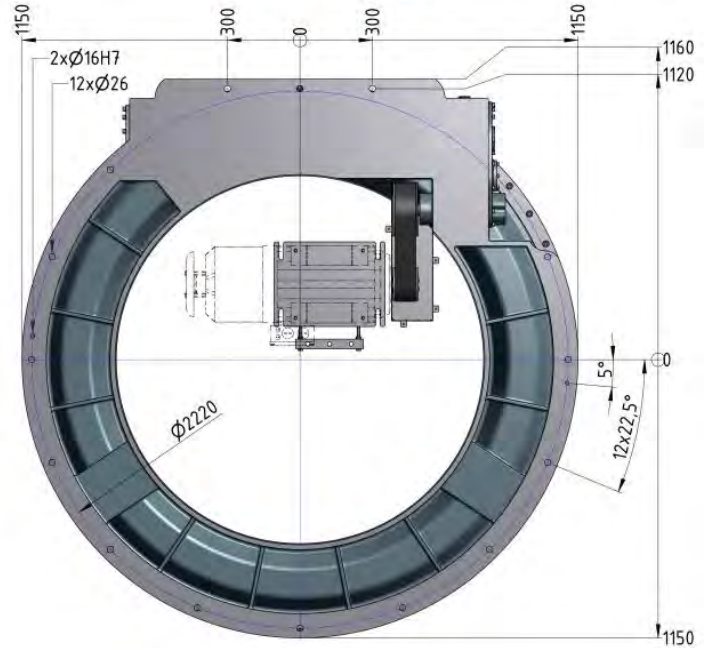
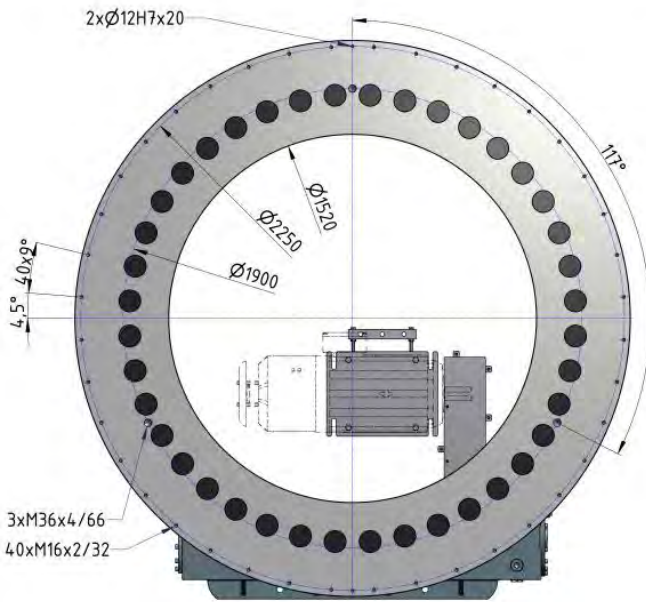
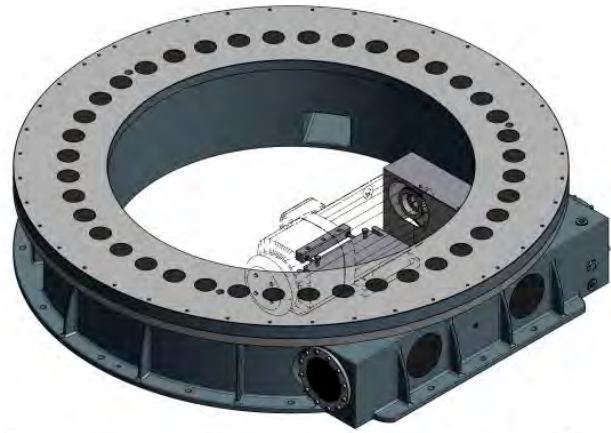
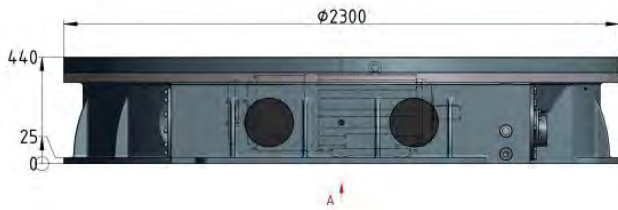

TMF8000

Dimensions	
Diameter output flange	2,300 mm
Overall height (mounting surface dial)	440 mm
Center thru-hole	1,520 mm
Maximum recommended swing diameter	16,000 mm
Weight	3,800 kg
Load Ratings	
Axial	4,280,000 N
Radial	1,000,000 N
Tilting	1,850,000 Nm

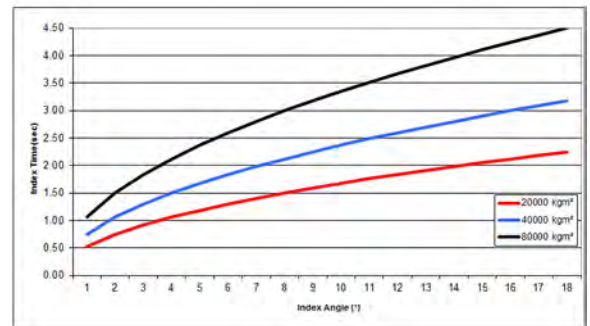

*Please note, the load chart shown can be affected by user programming required, including acceleration rates, deceleration rates, velocity profiles, e-stop times required, etc. For validation of sizing, please verify all loading with Motion Index Drives, Inc.

The dimensions shown here are the standard dimensions. The output flange, central column, housing and input shafts can be machined to your specifications. The central column can also be designed as a flange. Should you wish to drill a additional holes, please consult us with regard to acceptable drilling depth.



The dimensions for the gearmotor may change based on the gearmotor size and options required for the application.



MOTION INDEX DRIVES

ROTARY INDEX TABLES RT Series

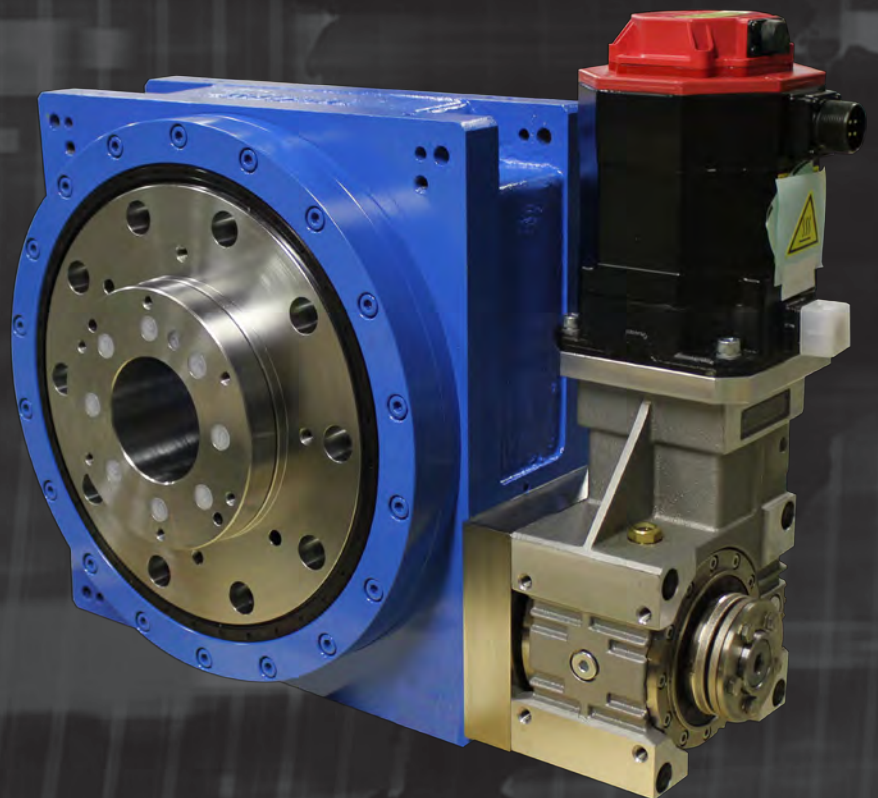



MOTION INDEX DRIVES



Advantages for design engineers and special machine builder

- Housing machined on all sides. Suitable for use in any mounting position required.
- Mounting holes identical on top and bottom.
- Large center thru-hole which is large enough to feed entire shafts through, and not just small wiring looms.
- Dowel holes in housing and in output flange.
- Recessed center column. No obstruction. Lengthened and machined to customer requirements.
- Simultaneously rotating input shaft extension. Optional synchronization of other mechanical modules.

Options for individual customer requirements

- Choice of drive unit/gear motor.
- Reinforced output flange bearing for higher tilting moment.
- Optional friction clutch on drive
- Dwell and index angle can be tailored to requirements.
- All sizes also available as programmable index tables.
- Custom specified color at no extra charge.

Technical benefits for users

- High reliability and long service life.
- Robust method of construction.
- Hardened cams: smaller sizes for higher load factors.
- Bearings fully immersed in oil bath.
- Cam followers self lubricating through oil bath.
- No wear. Completely maintenance-free*.

Fixed Index Drives

The rotary index table transforms a constant input drive motion into an intermittent output drive motion. The intermittent drive motion occurs by means of a hardened and high accuracy barrel cam. The use of mathematical laws of motion guarantees a soft, shock-proof, and jerk free movement that has been optimally designed for its intended purpose. The design allows for accurate and secure mounting to the output dial. The preload of the cam to the cam followers in dwell ensures the top dial is backlash free. No additional adjustment of the output dial is necessary.

The power is provided either by means of a three-phase motor via a gear reducer or by means of a timing chain/belt on the drive shaft of the rotary index table. This is firmly connected to the barrel cam, without any further internal gear sets, and it turns the cam followers and subsequently the output flange. The output dial is mounted to a wire bearing assembly (4 point contact bearing), which is preloaded to eliminate any runout. The index drive is completely sealed to eliminate intrusion from foreign particulate.

Programmable Index Drives

The rotary index table transforms a constant input drive motion into a constant output drive motion. The drive motion occurs by means of a hardened and high-accuracy constant lead barrel cam. The use of mathematical laws of motion along with a properly programmed motor profile guarantee a soft, shock proof, and jerk free movement that has been optimally designed for its intended purpose. The design allows for accurate and secure mounting to the output dial. The preload of the cam to the cam followers in dwell ensures the top dial is backlash free. No additional adjustment of the output dial is necessary. The power to rotate the index drive is provided either by means of a three phase AC motor with encoder, coupled to a gear reducer, or a servo motor coupled to a gear reducer. The gear reducer is connected to the input shaft which is firmly connected to the internal barrel cam with no further internal gearing. The barrel cam in turn rotates the top dial through the cam followers with a zero backlash internal design. The output dial is mounted to a wire bearing assembly (4 point contact bearing), which is preloaded to eliminate any runout. The index drive is completely sealed to eliminate intrusion from foreign particulate.

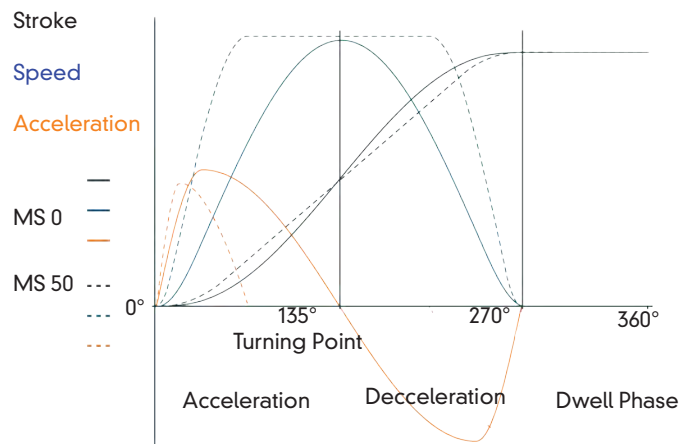

* The top bearing on the RT400, RT500, RT630 and RT900 needs to be lubricated at maintenance intervals (see operating manual)



MOTION INDEX DRIVES

RT100

For mounted accessories up to \varnothing 800mm. For rapid assembly of small parts, inspection or feeding parts.



RT100 Technical specifications

Main dimensions

Output flange Ø [mm]	120
Overall height (output flange screw-on surface) [mm]	112
Center opening Ø [mm]	20H8
Recommended max. size of rotating plate Ø [mm]	800
Index table weight [kg]	16
Number of indexes	2,3,4,6,8,10,12,16,20,24,30,36
Other numbers on request	

Standard drives

Motor	SEW
Gear unit	SEW
Motor size	56-71
Voltage [V]	ANY
Power [kW]	0.09-0.37

Precision*

Index precision	
In radian measure on cam follower Ø [mm]	±0.008
In angular seconds Ø ["]	±35
Axial runout on cam follower Ø [mm]	0.01
Concentricity on cam follower Ø [mm]	0.01

Load on output flange

Axial force Fa [kN]	6
Radial force Fr [kN]	3.8
Tilting moment Mk [kNm]	0.7
Reinforced version	
Tilting moment Mk [kNm]	1.5

Load on central column

Axial force Fa [kN]	5
Tilting moment Mk [kNm]	0.19

Max. number of cycles [1/min]	280
Direction	clockwise, counterclockwise, oscillating
Mounting position	Any

* The precision is 5 - 8 angular seconds greater at 16 or more indexes due to multiple dwell on the drive cam.

*If required, higher accuracy can be achieved upon request.

Load on output flange

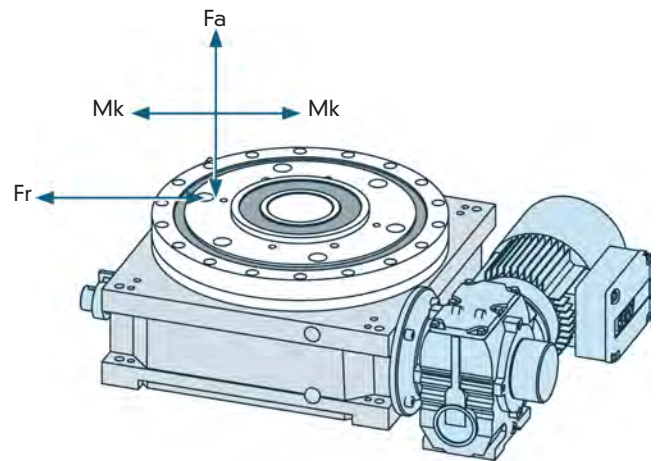

Load on central column

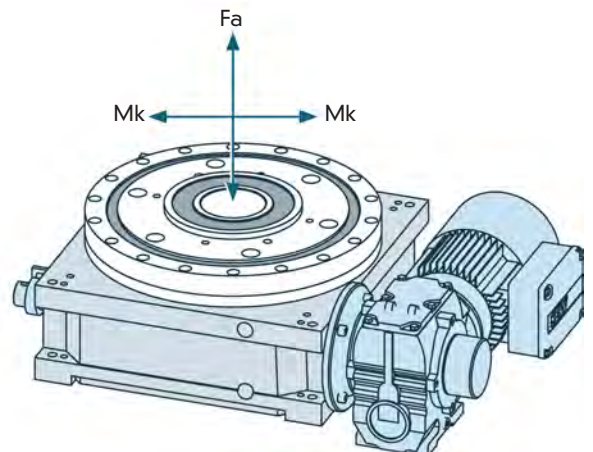

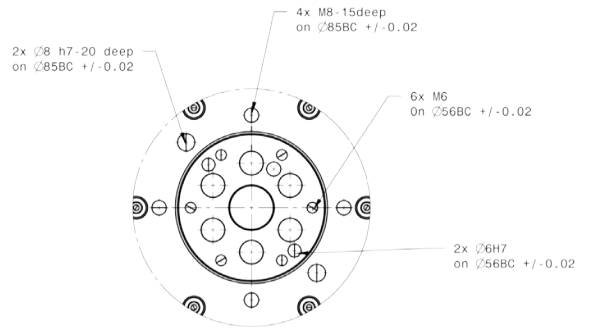
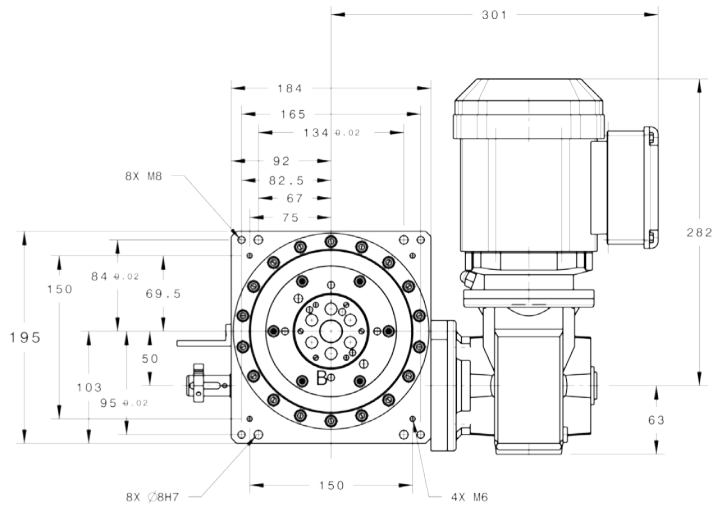

Detail: B

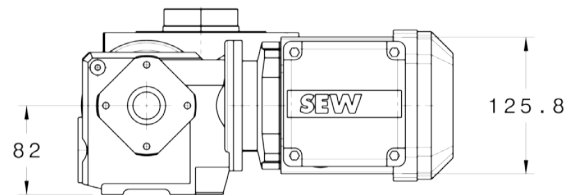
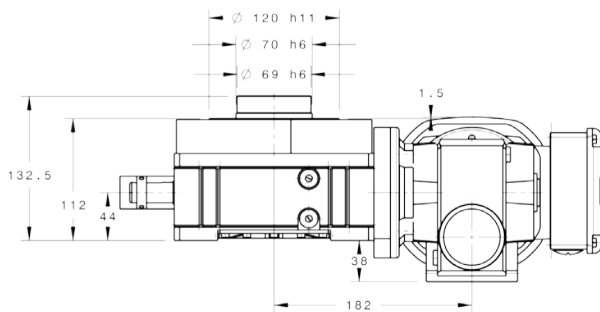

RT100 Dimensions

The dimensions shown here are the standard dimensions. The output flange, central column, housing and input shafts can be machined to your specifications. The central column can also be designed as a flange. Should you wish to drill additional holes, please consult us with regard to acceptable drilling depth.



The dimensions for the gearmotor may change based on the gearmotor size and options required for the application.

A = Length of input shaft

B = Length of shaft to collar

C = Diameter of input shaft

D = Height of central column to supporting surface on output flange

RT100 Load Table

Scenarios

		Scenarios												
		1	2	3	4	5	6	7	8	9	10	11	12	13
2	t			0.38	0.57	0.76	1.07	1.52	1.87	2.13	2.37	2.9	3.32	4.27
	J			0.22	0.56	1.1	2.4	5.4	8.6	11.7	14.9	23.7	32	57
3	t		0.25	0.36	0.54	0.71	1	1.43	1.75	2	2.22	2.72	3.11	4
	J		0.13	0.38	0.97	1.9	4.1	9.3	14.8	20.2	25.7	41	56	99
4	t		0.22	0.32	0.48	0.64	0.9	1.29	1.58	1.8	2	2.45	2.8	3.6
	J		0.18	0.47	1.25	2.4	5.3	11.4	18	24.8	32.5	50	69	122
5	t		0.22	0.32	0.48	0.64	0.9	1.29	1.58	1.8	2	2.45	2.8	3.6
	J		0.26	0.66	1.7	3.3	7	16	26	35	44	71	97	173
6	t		0.22	0.32	0.48	0.64	0.9	1.29	1.58	1.8	2	2.45	2.8	3.6
	J		0.32	0.9	2.25	4.3	9.3	21	34	46	58	93	127	226
8	t	0.19	0.22	0.32	0.48	0.64	0.9	1.259	1.58	1.8	2	2.45	2.8	3.6
	J	0.39	0.48	1.3	3.3	6.4	13.8	31.5	50	68	87	138	183	297
10	t	0.19	0.22	0.32	0.48	0.64	0.9	1.29	1.58	1.8	2	2.45	2.8	
	J	0.52	0.64	1.72	4.4	8.5	18.5	42	67	92	115	171	225	
12	t	0.19	0.22	0.32	0.48	0.64	0.9	1.29	1.58	1.8	2	2.45	2.8	
	J	0.65	0.82	2.16	5.5	10.6	23	52	83	113	145	210	246	
16	t			0.16	0.24	0.32	0.45	0.64	0.79	0.9	1	1.23	1.4	
	J			0.95	2.4	4.6	9	19	29	38	46	70	91	
20	t			0.16	0.24	0.32	0.45	0.64	0.79	0.9	1	1.23	1.4	
	J			1.28	3.2	6	11.8	24	36	47	58	88	115	
24	t			0.16	0.24	0.32	0.45	0.64	0.79	0.9	1	1.23	1.4	
	J			1.6	4.1	7	14	29	43	57	70	105	138	
30	t			0.16	0.24	0.32	0.45	0.64	0.79	0.9	1	1.23	1.4	
	J			1.7	4.5	8.6	16	32	48	62	79	119	155	
36	t			0.16	0.21	0.3	0.43	0.53	0.6	0.67	0.82	0.93		
	J			2.46	4.32	8.6	17	29	38	47	63	83		

J = Mass moment of inertia in Kg^m²

t = Mechanical index time in seconds (does not include dwell)

All RT Series tables available in servo programmable versions.

Please contact MID for load capabilities of this index drive in the programmable configuration.



MOTION INDEX DRIVES

RT160

Small design envelope, big performance. For mounted accessories up to \varnothing 1300 mm.
Applications in assembly facilities for medium-sized parts: welding, riveting, assembling,
printing/labeling.



RT160 Technical specifications

Main dimensions

Output flange Ø [mm]	185
Overall height (output flange screw-on surface) [mm]	140
Center opening Ø [mm]	50H8
Recommended max. size of rotating plate Ø [mm]	1300
Index table weight [kg]	31
Number of indexes	2,3,4,6,8,10,12,16,20,24,30,36
Other numbers on request	

Standard drives

Motor	SEW
Gear unit	SEW
Motor size	71-80
Voltage [V]	ANY
Power [kW]	0.18-0.75

Precision*

Index precision	
In radian measure on cam follower Ø [mm]	±0.012
In angular seconds Ø ["]	±30
Axial runout on cam follower Ø [mm]	0.01
Concentricity on cam follower Ø [mm]	0.01

Load on output flange

Axial force Fa [kN]	15
Radial force Fr [kN]	8
Tilting moment Mk [kNm]	2.7
Reinforced version	
Tilting moment Mk [kNm]	5

Load on central column

Axial force Fa [kN]	7.5
Tilting moment Mk [kNm]	0.53

Max. number of cycles [1/min]

Direction	clockwise, counterclockwise, oscillating
Mounting position	ANY

* The precision is 5 - 8 angular seconds greater at 16 or more indexes due to multiple dwell on the drive cam.

*If required, higher accuracy can be achieved upon request.

Load on output flange

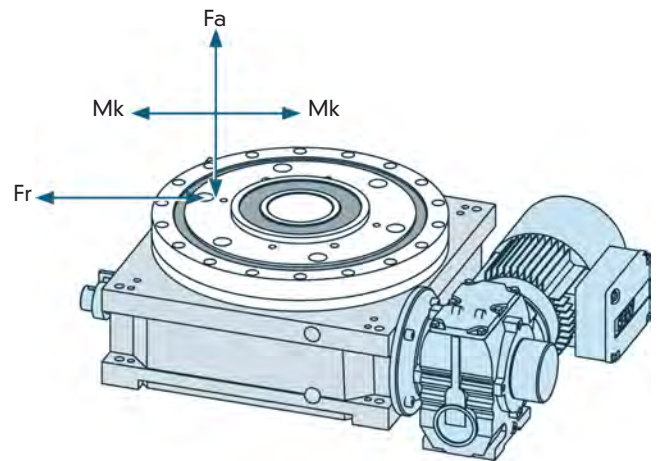

Load on central column

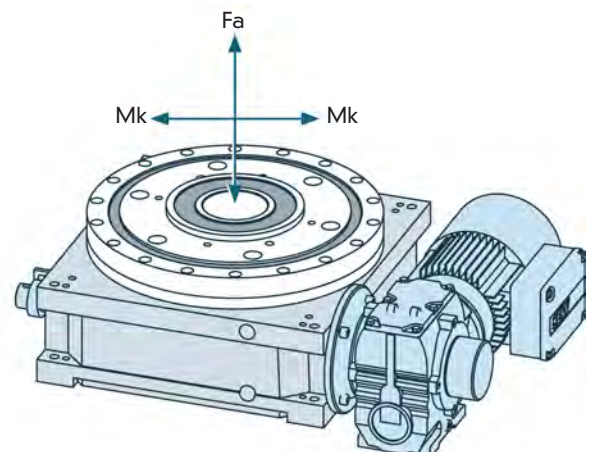

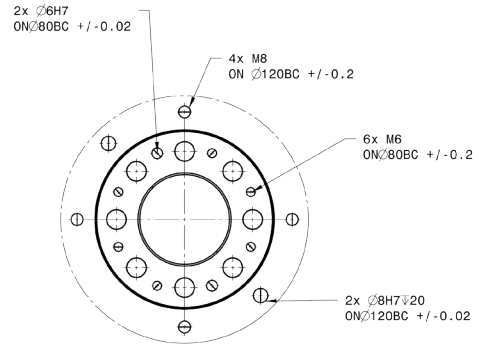
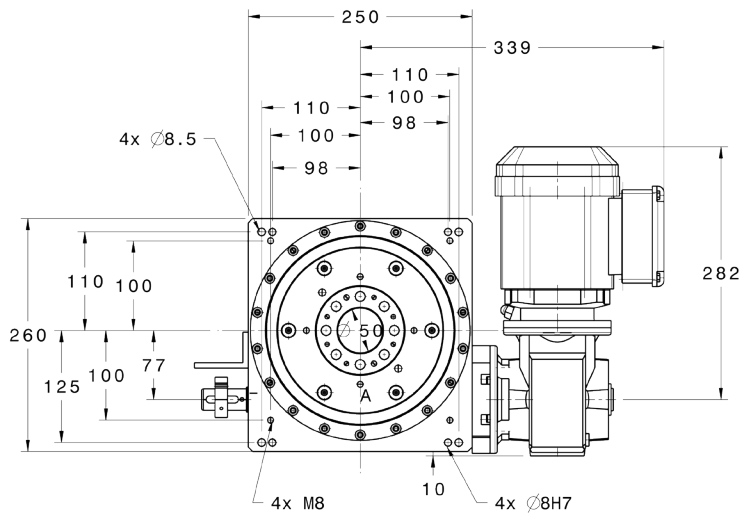

Detail A

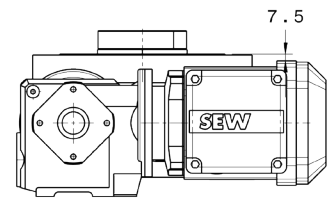
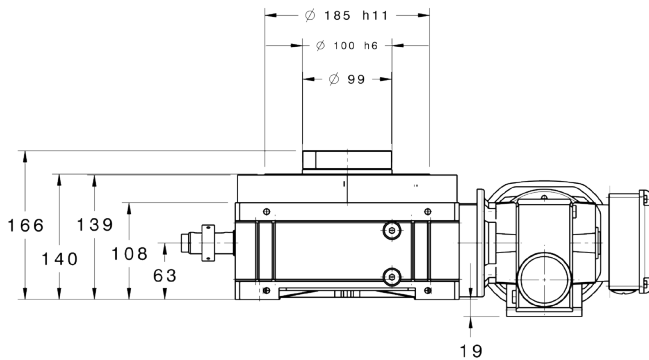

RT160 Dimensions

The dimensions shown here are the standard dimensions. The output flange, central column, housing and input shafts can be machined to your specifications. The central column can also be designed as a flange. Should you wish to drill additional holes, please consult us with regard to acceptable drilling depth.



The dimensions for the gearmotor may change based on the gearmotor size and options required for the application.

A = Length of input shaft

B = Length of shaft to collar

C = Diameter of input shaft

D = Height of central column to supporting surface on output flange

RT160 Load Table

Scenarios

		Scenarios												
		1	2	3	4	5	6	7	8	9	10	11	12	13
2	t				0.57	0.76	1.07	1.52	1.87	2.13	2.37	2.9	3.32	4.27
	J				1.5	3.7	7.5	17	21	31	46	65	85	145
3	t			0.36	0.54	0.71	1	1.43	1.75	2	2.22	2.72	3.11	4
	J			1.05	3.4	5.3	12.5	29	41	55	71	112	152	215
4	t		0.21	0.32	0.48	0.64	0.9	1.29	1.58	1.8	2	2.45	2.8	3.6
	J		0.35	1.3	4.2	7.8	16	33	51	69	91	143	193	268
5	t		0.21	0.32	0.48	0.64	0.9	1.29	1.58	1.8	2	2.45	2.8	3.6
	J		0.55	1.85	5.8	9	22	46	72	98	127	201	272	385
6	t		0.21	0.32	0.48	0.64	0.9	1.29	1.58	1.8	2	2.45	2.8	3.6
	J		0.85	2.6	6.5	13	31	65	103	135	169	285	372	540
8	t	0.19	0.21	0.32	0.48	0.64	0.9	1.259	1.58	1.8	2	2.45	2.8	
	J	1.05	1.4	3.9	9.5	22	41	92	143	195	243	389	512	
10	t	0.02	0.22	0.32	0.48	0.64	0.9	1.29	1.58	1.8	2	2.45	2.8	
	J	1.65	2.15	5.8	14	26	56	125	198	258	325	480	620	
12	t	0.19	0.21	0.32	0.48	0.64	0.9	1.29	1.58	1.8	2	2.45	2.8	
	J	2.05	2.6	7.5	17.5	33	72	158	255	345	430	643	873	
16	t			0.16	0.24	0.32	0.45	0.64	0.79	0.9	1	1.23	1.4	
	J			2.35	7.5	14	27.5	56	89	121	148	224	291	
20	t			0.16	0.24	0.32	0.45	0.64	0.79	0.9	1	1.23	1.4	
	J			3.5	9	17.5	38	72	110	152	190	275	360	
24	t			0.16	0.24	0.32	0.45	0.64	0.79	0.9	1	1.23	1.4	
	J			4.5	11.4	22	42	92	130	182	220	330	430	
30	t			0.16	0.24	0.32	0.45	0.64	0.79	0.9	1	1.23	1.4	
	J			6.1	15.5	30.1	55	110	170	220	280	420	540	
36	t				0.16	0.21	0.3	0.43	0.53	0.6	0.67	0.82	0.93	1.2
	J				8.5	15	30	61	92	120	145	220	290	430

of Stops

J = Mass moment of inertia in Kgm²

t = Mechanical index time in seconds (does not include dwell)

All RT Series tables available in servo programmable versions.



MOTION INDEX DRIVES

RT200

Small design envelope, big performance. For mounted accessories up to \varnothing 1800 mm.
Applications in assembly facilities for medium-sized parts: welding, riveting,
assembling, printing/labeling.



RT200

Technical specifications

Main dimensions

Output flange Ø [mm]	240
Overall height (output flange screw-on surface) [mm]	160
Center opening Ø [mm]	60H8
Recommended max. size of rotating plate Ø [mm]	1800
Index table weight [kg]	63
Number of indexes	2,3,4,6,8,10,12,16,20,24,30,36
Other numbers on request	

Standard drives

Motor	SEW
Gear unit	SEW
Motor size	71-90
Voltage [V]	ANY
Power [kW]	0.25-1.10

Precision*

Index precision	
In radian measure on cam follower Ø [mm]	±0.015
In angular seconds Ø ["]	±30
Axial runout on cam follower Ø [mm]	0.01
Concentricity on cam follower Ø [mm]	0.01

Load on output flange

Axial force Fa [kN]	21
Radial force Fr [kN]	11
Tilting moment Mk [kNm]	3.7
Reinforced version	
Tilting moment Mk [kNm]	7

Load on central column

Axial force Fa [kN]	12.5
Tilting moment Mk [kNm]	1.2

Max. number of cycles [1/min]

Direction	clockwise, counterclockwise, oscillating
Mounting position	ANY

* The precision is 5 - 8 angular seconds greater at 16 or more indexes due to multiple dwell on the drive cam.

*If required, higher accuracy can be achieved upon request.

Load on output flange

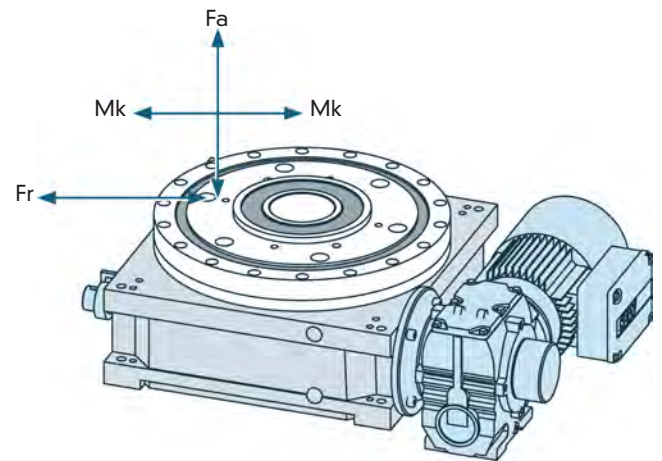

Load on central column

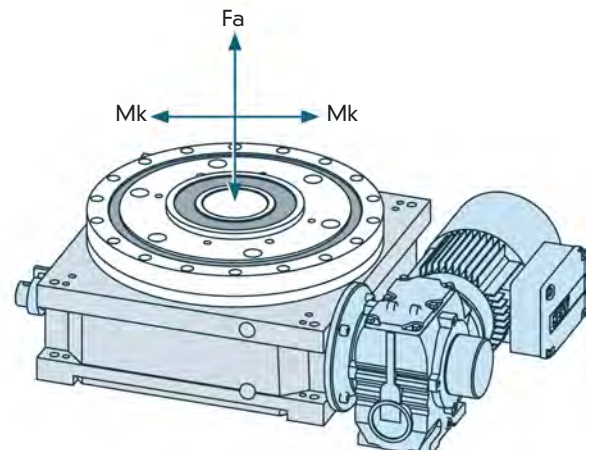

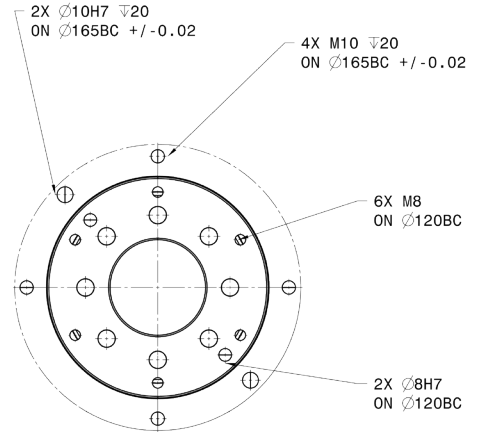
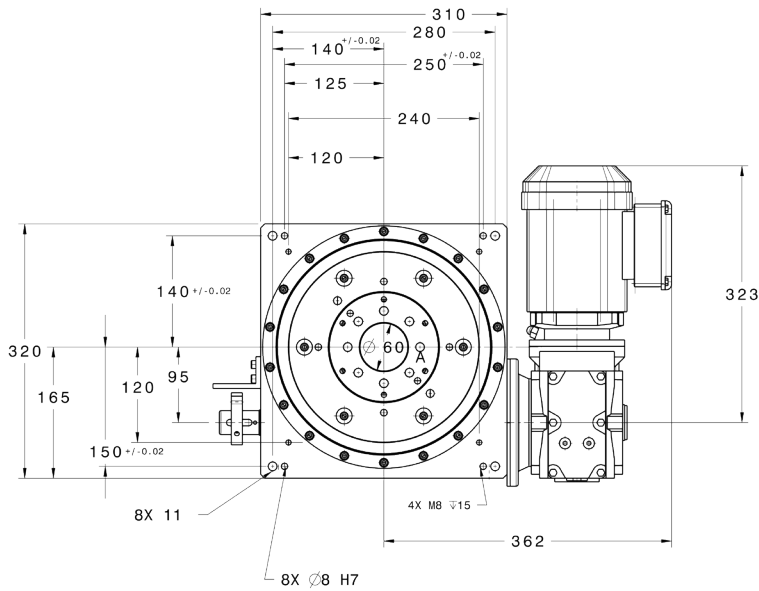

Detail A

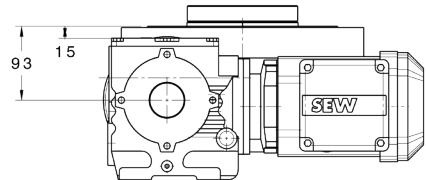
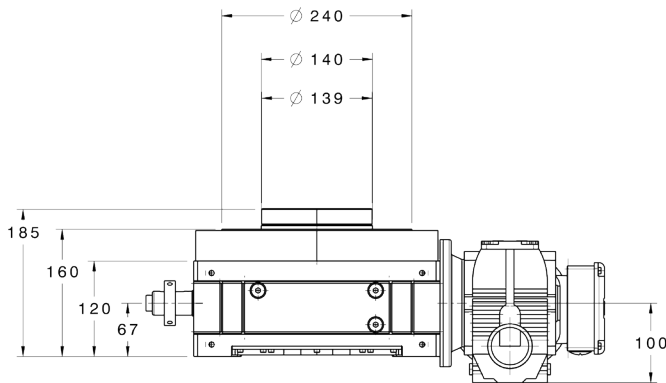

RT200 Dimensions

The dimensions shown here are the standard dimensions. The output flange, central column, housing and input shafts can be machined to your specifications. The central column can also be designed as a flange. Should you wish to drill additional holes, please consult us with regard to acceptable drilling depth.



The dimensions for the gearmotor may change based on the gearmotor size and options required for the application.

A = Length of input shaft

B = Length of shaft to collar

C = Diameter of input shaft

D = Height of central column to supporting surface on output flange

RT200 Load Table

Scenarios

		Scenarios												
		1	2	3	4	5	6	7	8	9	10	11	12	13
2	t				0.57	0.76	1.07	1.52	1.87	2.13	2.37	2.9	3.32	4.27
	J				3.0	5.4	10.5	21	32	42	52	78	103	168
3	t			0.36	0.54	0.71	1	1.43	1.75	2	2.22	2.72	3.13	4
	J			2.6	5.8	10.3	20	41	62	81	100	150	198	324
4	t			0.32	0.48	0.64	0.9	1.29	1.58	1.8	2	2.45	2.81	3.6
	J			3.1	7.1	12.5	25	50	76	98	121	182	240	393
5	t			0.32	0.48	0.64	0.9	1.29	1.58	1.8	2	2.45	2.81	3.6
	J			4.6	10.3	18	36	73	111	144	178	267	352	576
6	t			0.32	0.48	0.64	0.9	1.29	1.58	1.8	2	2.45	2.81	3.6
	J			6.1	13.7	24	48	97	147	191	235	353	465	762
8	t			0.32	0.48	0.64	0.9	1.29	1.58	1.80	2	2.45	2.81	3.6
	J			9.1	21	37	72	146	220	286	354	531	699	1146
10	t			0.32	0.48	0.64	0.9	1.29	1.58	1.8	2	2.45	2.81	
	J			12.2	27.5	49	96	195	295	383	473	710	935	
12	t			0.32	0.48	0.64	0.9	1.29	1.58	1.8	2	2.45	2.81	
	J			15.3	34	61	120	244	368	479	591	888	1169	
16	t	0.16	0.24	0.32	0.45	0.64	0.79	0.9	1	1.23	1.41	1.8		
	J	4.6	10.3	18	36	73	110	143	177	266	350	573		
20	t	0.16	0.24	0.32	0.45	0.64	0.79	0.9	1	1.23	1.41	1.8		
	J	6.1	13.8	24	48	98	147	192	236	355	468	766		
24	t	0.16	0.24	0.32	0.45	0.64	0.79	0.9	1	1.23	1.41	1.8		
	J	7.6	17.2	31	60	122	184	239	296	444	584	958		
30	t	0.16	0.24	0.32	0.45	0.64	0.79	0.9	1	1.23	1.41	1.8		
	J	9.9	22	40	78	158	239	310	383	575	757	1241		
36	t	0.11	0.16	0.3	0.43	0.53	0.6	0.67	0.82	0.94	1.2			
	J	5.1	11	40	81	123	160	197	296	390	638			

J = Mass moment of inertia in Kgm²

t = Mechanical index time in seconds (does not include dwell)

All RT Series tables available in servo programmable versions.



MOTION INDEX DRIVES

RT250

From small parts to heavy duty. For mounted accessories up to \varnothing 2200mm. Applications in assembly facilities with relatively large and heavy parts: welding, riveting, assembling, printing/labeling.

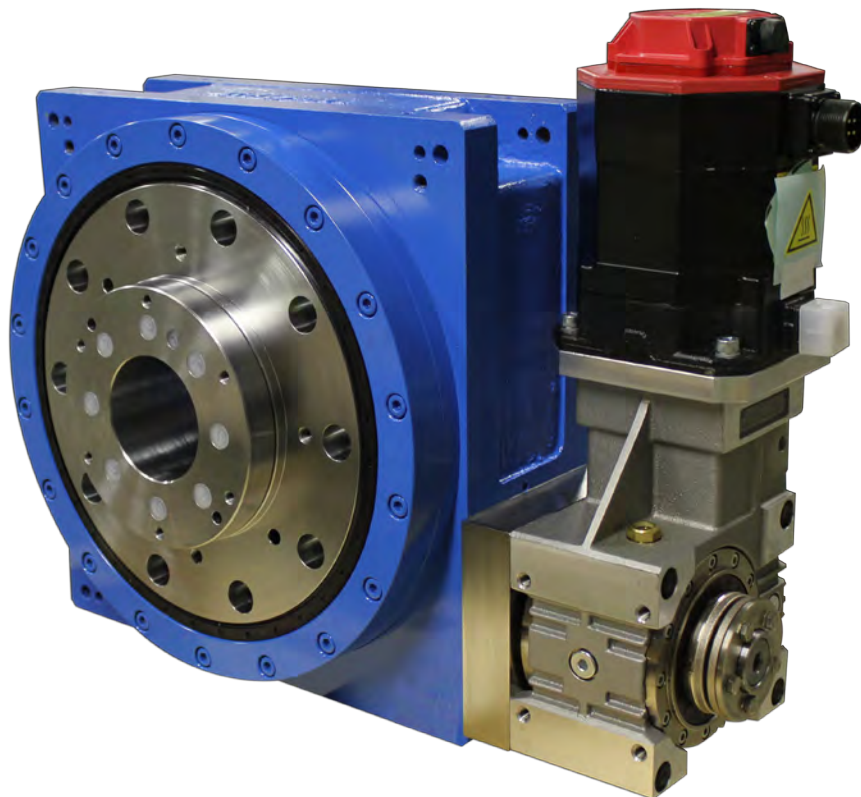

RT250 Technical specifications

Main dimensions

Output flange Ø [mm]	285
Overall height (output flange screw-on surface) [mm]	174
Center opening Ø [mm]	80H8
Recommended max. size of rotating plate Ø [mm]	2200
Index table weight [kg]	100
Number of indexes	2, 3, 4, 6, 8, 10, 12, 16, 20, 24, 30, 36
Other numbers on request	

Standard drives

Motor	SEW
Gear unit	SEW
Motor size	71-100
Voltage [V]	ANY
Power [kW]	0.18-1.5

Precision*

Index precision	
In radian measure on cam follower Ø [mm]	±0.015
In angular seconds Ø ["]	±25
Axial runout on cam follower Ø [mm]	0.01
Concentricity on cam follower Ø [mm]	0.01

Load on output flange

Axial force Fa [kN]	27
Radial force Fr [kN]	14
Tilting moment Mk [kNm]	5
Reinforced version	
Tilting moment Mk [kNm]	9

Load on central column

Axial force Fa [kN]	25
Tilting moment Mk [kNm]	2

Max. number of cycles [1/min]	220
Direction	clockwise, counterclockwise, oscillating
Mounting position	ANY

* The index precision is 5 - 8 angular seconds greater at 16 or more indexes due to multiple dwell on the drive cam.

*If required, higher accuracy can be achieved upon request.

Load on output flange

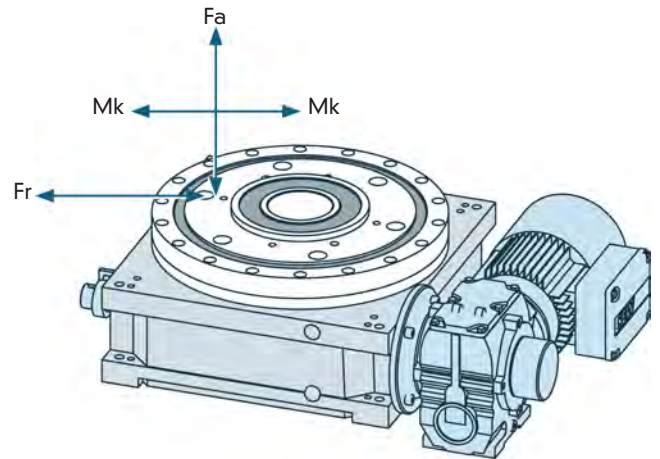

Load on central column

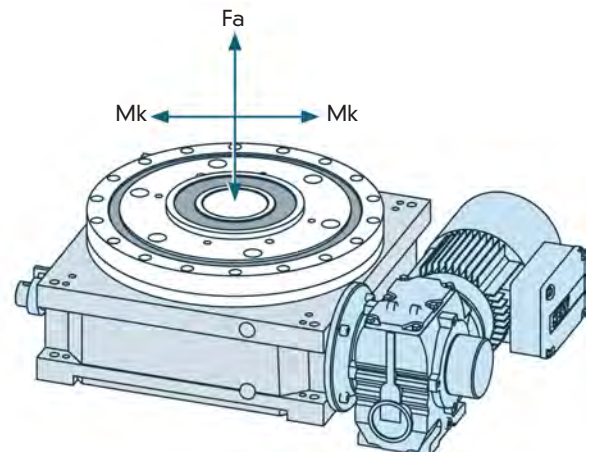

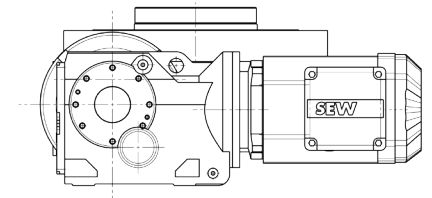
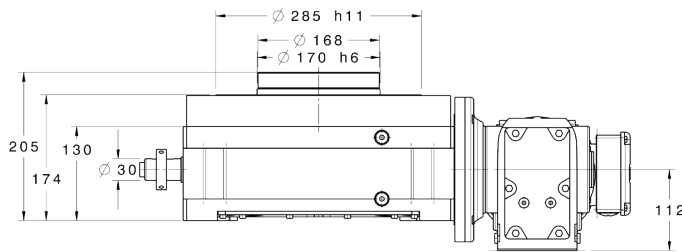
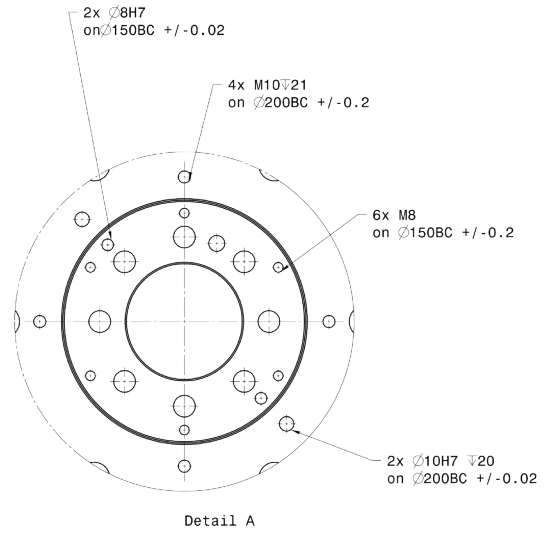
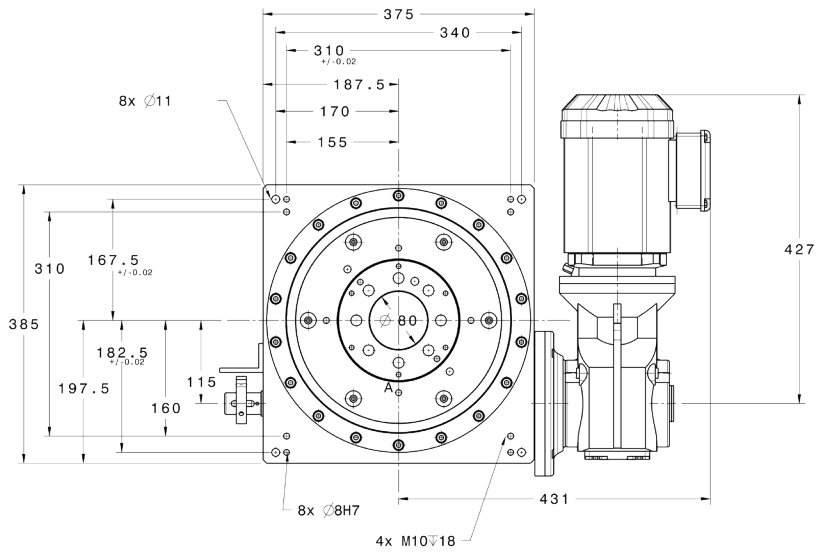

RT250 Dimensions

The dimensions shown here are the standard dimensions. The output flange, central column, housing and input shafts can be machined to your specifications. The central column can also be designed as a flange. Should you wish to drill additional holes, please consult us with regard to acceptable drilling depth.



The dimensions for the gearmotor may change based on the gearmotor size and options required for the application.

A = Length of input shaft

B = Length of shaft to collar

C = Diameter of input shaft

D = Height of central column to supporting surface on output flange

RT250 Load Table

		Scenarios										
		1	2	3	4	5	6	7	8	9	10	11
2	t		0.57	0.76	1.07	1.52	1.87	2.13	2.37	2.9	3.32	4.27
	J		3.8	6.8	13	32	41	48	78	105	201	243
3	t		0.54	0.71	1	1.43	1.75	2	2.22	2.72	3.11	4
	J		7	13	26	64	85	110	170	230	320	390
4	t	0.32	0.48	0.64	0.9	1.29	1.58	1.8	2	2.45	2.8	3.6
	J	3.2	8	17.5	35	79	112	154	210	270	390	490
5	t	0.32	0.48	0.64	0.9	1.29	1.58	1.8	2	2.45	2.8	3.6
	J	4.8	11.5	22.5	45	123	162	229	325	385	550	715
6	t	0.32	0.48	0.64	0.9	1.29	1.58	1.8	2	2.45	2.8	3.6
	J	6.95	18	32	63	143	228	311	392	580	775	1050
8	t	0.32	0.48	0.64	0.9	1.29	1.58	1.8	2	2.45	2.8	3.6
	J	12.5	24	48	98	225	362	505	620	840	1120	1760
10	t	0.32	0.48	0.64	0.9	1.29	1.58	1.8	2	2.45	2.8	
	J	13.5	32	62	132	295	451	631	780	1125	1580	
12	t	0.32	0.48	0.64	0.9	1.29	1.58	1.8	2	2.45	2.8	
	J	16.2	41	73	158	330	523	725	920	1310	1760	
16	t		0.24	0.32	0.45	0.64	0.79	0.9	1	1.23	1.4	
	J		17.3	32	61	112	178	225	287	430	560	
20	t		0.24	0.32	0.45	0.64	0.79	0.9	1	1.23	1.4	
	J		21	36.5	71	149	218	289	360	530	695	
24	t		0.24	0.32	0.45	0.64	0.79	0.9	1	1.23	1.4	
	J		23.5	44.5	87	170	263	345	413	630	823	
30	t		0.24	0.32	0.45	0.64	0.79	0.9	1	1.23	1.4	
	J		31	55	108	215	320	425	532	795	1030	
36	t			0.21	0.3	0.43	0.53	0.6	0.67	0.82	0.93	1.2
	J			27	55	115	170	230	275	420	545	920

J = Mass moment of inertia in Kgm²

t = Mechanical index time in seconds (does not include dwell)

All RT Series tables available in servo programmable versions.



MOTION INDEX DRIVES

RT400

For mounted accessories up to \varnothing 3500mm. Applications in assembly facilities with large and heavy parts: welding, riveting, assembling, and printing/labeling.



RT400 Technical specifications

Main dimensions

Output flange Ø [mm]	460
Overall height (output flange screw-on surface) [mm]	316
Center opening Ø [mm]	110H8
Recommended max. size of rotating plate Ø [mm]	3500
Index table weight [kg]	325
Number of indexes	2,3,4,6,8,10,12,16,20,24,30,36
Other numbers on request	

Standard drives

Motor	SEW
Gear unit	SEW
Motor size	71-132
Voltage [V]	ANY
Power [kW]	0.18-3.7

Precision*

Index precision	
In radian measure on cam follower Ø [mm]	±0.017
In angular seconds on cam follower Ø ["]	±18
Axial runout on cam follower Ø [mm]	0.01
Concentricity on cam follower Ø [mm]	0.01

Load on output flange

Axial force Fa [kN]	50
Radial force Fr [kN]	26
Tilting moment Mk [kNm]	10
Reinforced version	
Tilting moment Mk [kNm]	21

Load on central column

Axial force Fa [kN]	45
Tilting moment Mk [kNm]	5.5

Max. number of cycles [1/min]	145
Direction	clockwise, counterclockwise, oscillating
Mounting position	ANY

* The precision is 5 - 8 angular seconds greater at 16 or more indexes due to multiple dwell on the drive cam.

*If required, higher accuracy can be achieved upon request.

Load on output flange

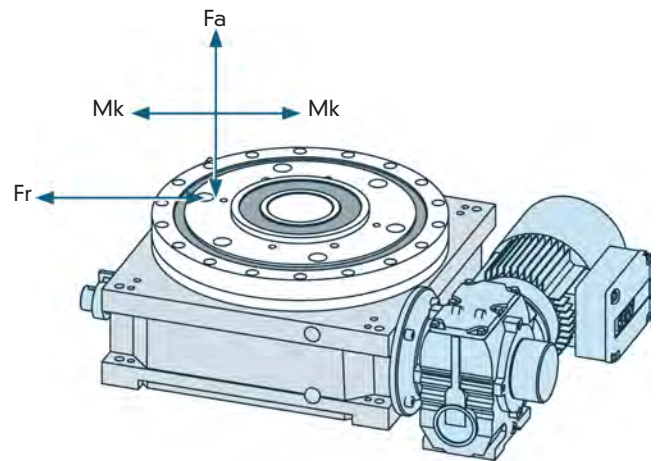

Load on central column

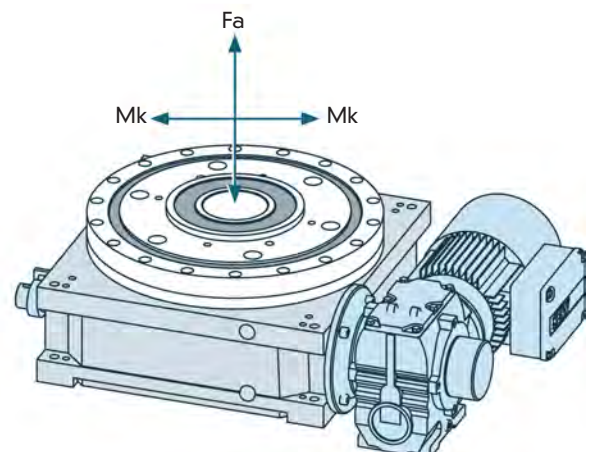

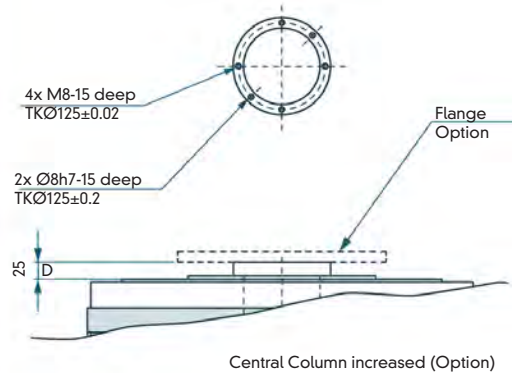
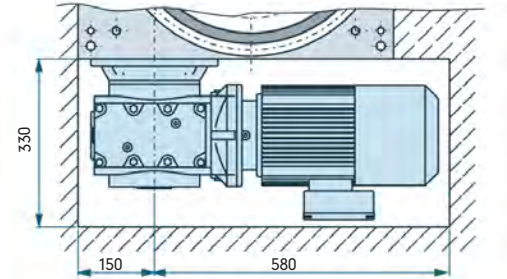
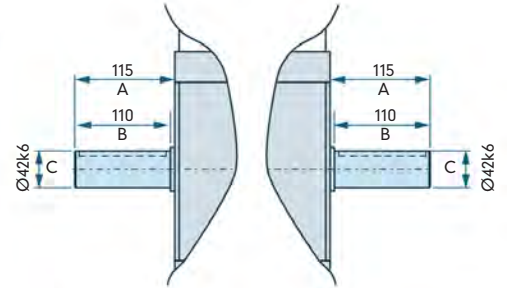
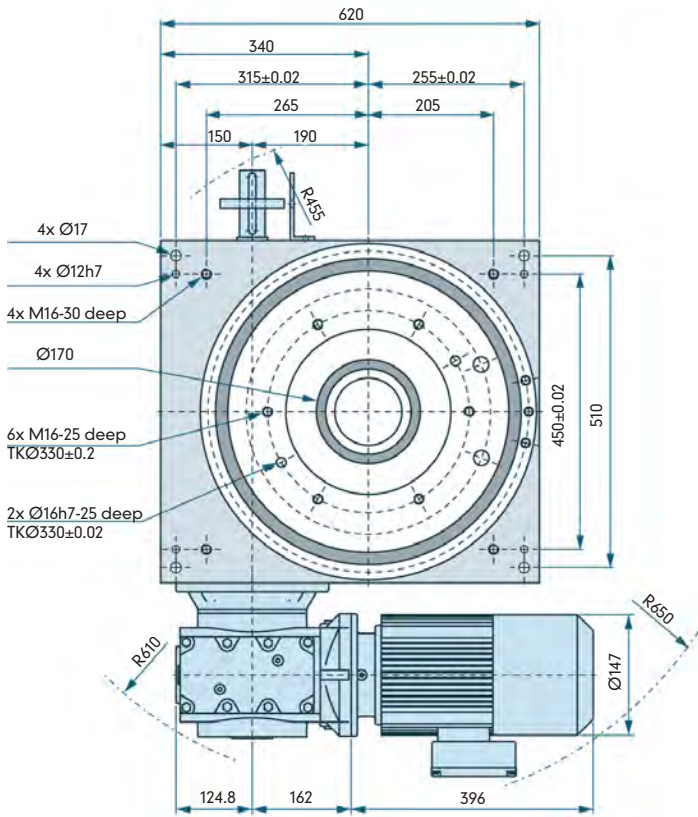
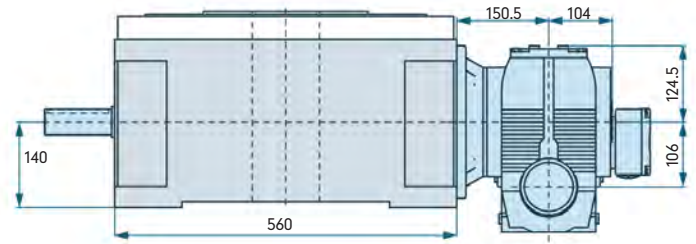
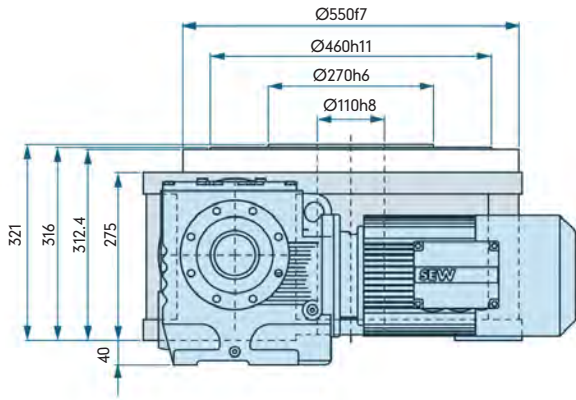

RT400 Dimensions

The dimensions shown here are the standard dimensions. The output flange, central column, housing and input shafts can be machined to your specifications. The central column can also be designed as a flange. Should you wish to drill additional holes, please consult us with regard to acceptable drilling depth.



The dimensions for the gearmotor may change based on the gearmotor size and options required for the application.

A = Length of input shaft

B = Length of shaft to collar

C = Diameter of input shaft

D = Height of central column to supporting surface on output flange

RT400 Load Table

		Scenarios										
		1	2	3	4	5	6	7	8	9	10	11
2	t	0.57	0.78	1.06	1.56	1.88	2.13	2.37	2.84	3.22	4.08	5.64
	J	15.7	30	67	178	275	334	445	655	910	1480	2310
3	t	0.54	0.74	1	1.45	1.74	2	2.22	2.67	3.02	4	5.29
	J	29.9	60.5	123	315	430	590	810	1230	1650	2830	5890
4	t	0.48	0.67	0.9	1.31	1.58	1.8	2	2.4	3.02	3.82	4.73
	J	38.5	81	168	395	570	765	1060	1520	2350	3950	6480
5	t	0.48	0.67	0.9	1.31	1.58	1.8	2	2.4	3.02	3.82	
	J	50	104	204	503	772	1075	1210	2025	3300	2150	
6	t	0.48	0.64	0.9	1.31	1.58	1.8	2	2.4	3.02	3.82	
	J	62	133	271	652	987	1300	1740	2645	3700	7250	
8	t	0.48	0.64	0.9	1.29	1.58	1.8	2	2.49	3.02	3.82	
	J	92	197	398	952	1472	2015	2580	3490	5800	9150	
10	t	0.49	0.64	0.9	1.34	1.58		2	2.49	3.02		
	J	135	281	565	1365	1980		3200	4980	6850		
12	t	0.49	0.64	0.9	1.34	1.58		2	2.49	3.04		
	J	172	358	705	1730	2410		3810	5900	8700		
16	t		0.33	0.46	0.66	0.79	0.91	1	1.24	1.37		
	J		141	206	560	790	1005	1300	1730	2360		
20	t		0.32	0.46	0.66	0.79	0.9	1	1.24	1.37		
	J		178	335	670	990	1320	1590	2480	2970		
24	t		0.32	0.45	0.66	0.79	0.87	1	1.2	1.37		
	J		215	397	860	1180	1470	1910	2760	3550		
30	t		0.34	0.48	0.67		0.88	1	1.22	1.4		
	J		275	550	1080		1850	2420	3490	4580		
36	t			0.32	0.45		0.59	0.67	0.82	0.93	1.32	
	J			292	582		990	1290	1840	2410	4820	

J = Mass moment of inertia in Kgm²

t = Mechanical index time in seconds (does not include dwell)

All RT Series tables available in servo programmable versions.



MOTION INDEX DRIVES

RT500

For mounted accessories up to \varnothing 4500mm. Applications in assembly facilities with large and heavy parts: welding, riveting, assembling, and printing/labeling.

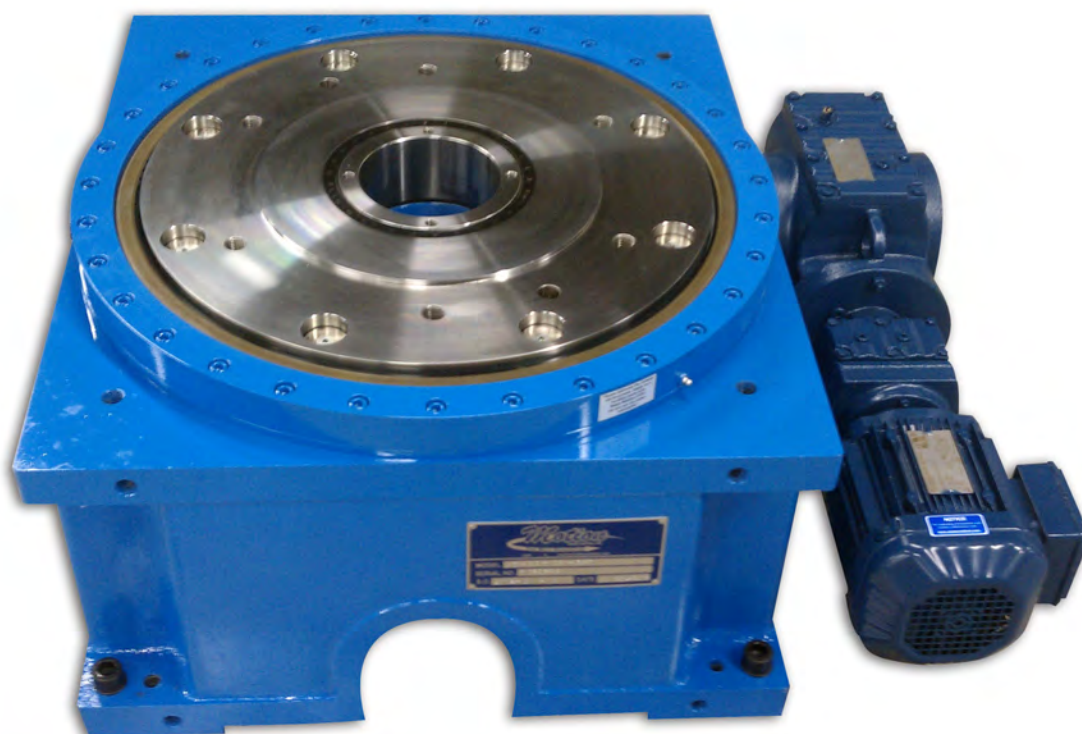

RT500 Technical specifications

Main dimensions

Output flange Ø [mm]	560
Overall height (output flange screw-on surface) [mm]	420
Center opening Ø [mm]	140H8
Recommended max. size of rotating plate Ø [mm]	4500
Index table weight [kg]	600
Number of indexes	2,3,4,6,8,10,12,16,20,24,30,36
Other numbers on request	

Standard drives

Motor	SEW
Gear unit	SEW
Motor size	71-132
Voltage [V]	ANY
Power [kW]	0.18-5.6

Precision*

Index precision	
In radian measure on cam follower Ø [mm]	±0.018
In angular seconds on cam follower Ø ["]	±15
Axial runout on cam follower Ø [mm]	0.01
Concentricity on cam follower Ø [mm]	0.01

Load on output flange

Axial force Fa [kN]	84
Radial force Fr [kN]	49
Tilting moment Mk [kNm]	22
Reinforced version	
Tilting moment Mk [kNm]	40

Load on central column

Axial force Fa [kN]	60
Tilting moment Mk [kNm]	7.8

Max. number of cycles [1/min] 105

Direction clockwise, counterclockwise, oscillating

Mounting position ANY

* The precision is 5 - 8 angular seconds greater at 16 or more indexes due to multiple dwell on the drive cam.

*If required, higher accuracy can be achieved upon request.

Load on output flange

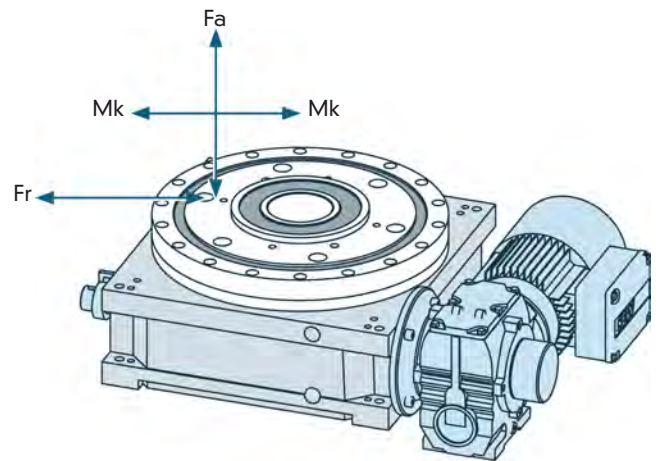

Load on central column

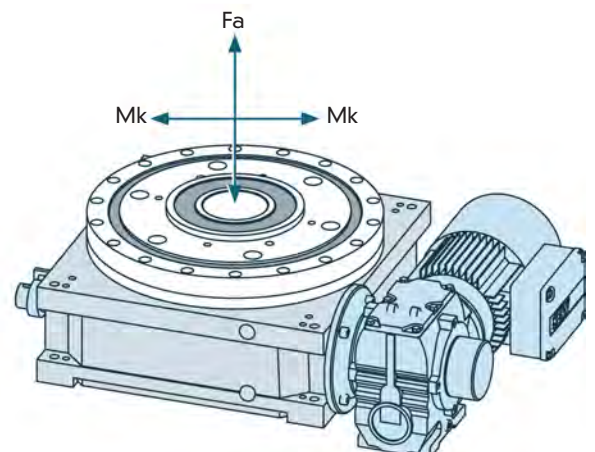

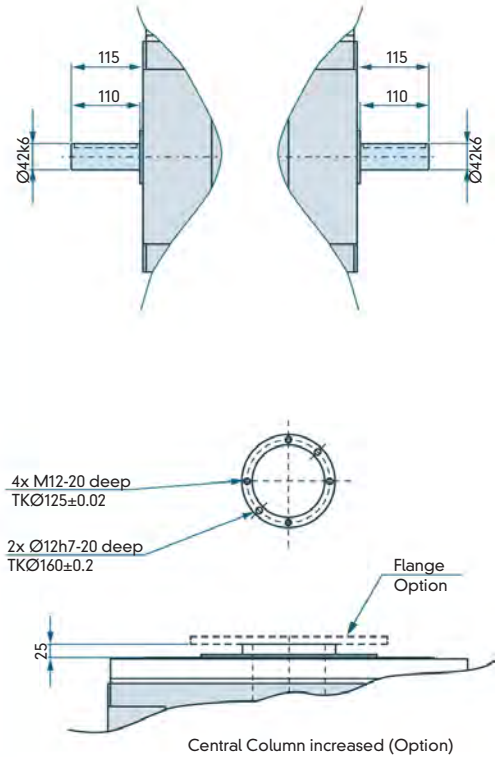
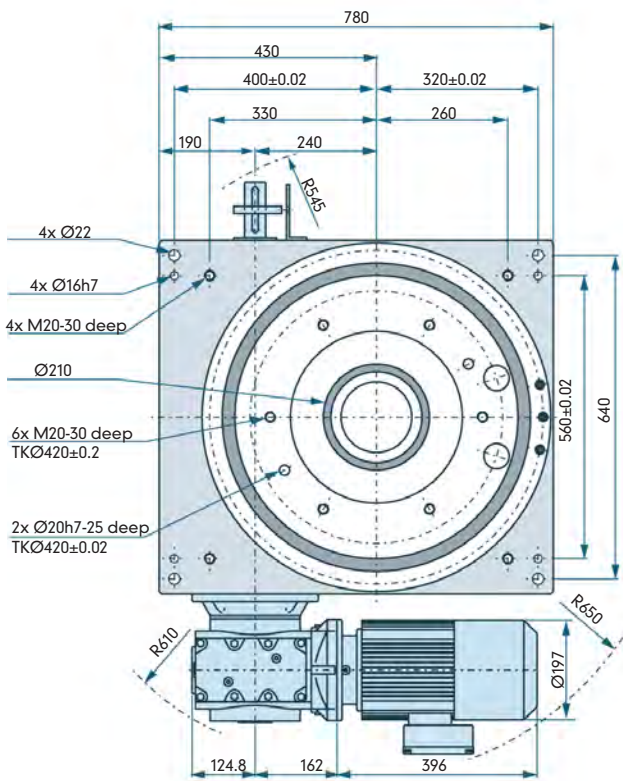
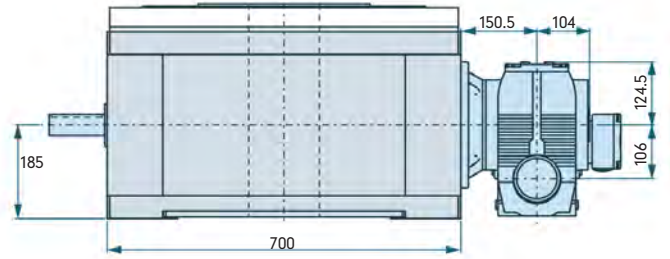
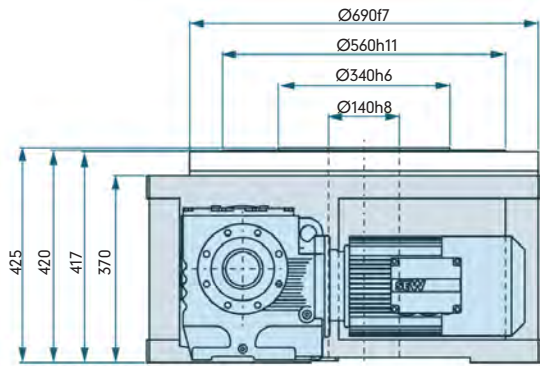

RT500 Dimensions

The dimensions shown here are the standard dimensions. The output flange, central column, housing and input shafts can be machined to your specifications. The central column can also be designed as a flange. Should you wish to drill additional holes, please consult us with regard to acceptable drilling depth.



The dimensions for the gearmotor may change based on the gearmotor size and options required for the application.

A = Length of input shaft

B = Length of shaft to collar

C = Diameter of input shaft

D = Height of central column to supporting surface on output flange

RT500 Load Table

Scenarios

		1	2	3	4	5	6	7	8	9	10	11	12	13
2	t			1.07	1.52	1.87	2.13	2.37	2.90	3.33	4.27	5.73	6.84	9.7
	J			199.5	407.14	614.03	798	985.18	1479.57	1948.23	3191.99	5766.54	8197.7	16487.53
3	t			1	1.43	1.75	2	2.22	2.72	3.13	4	5.38	6.41	9.09
	J			378.28	772	1164.3	1513.12	1868.05	2805.49	3694.15	6052.49	10934.23	15544.07	31262.85
4	t			1	1.43	1.75	2	2.22	2.72	3.13	4	5.38	6.41	9.09
	J			586.43	1196.8	1804.96	2345.73	2895.96	4349.23	5726.87	9382.91	16950.86	24097.3	48465.44
5	t			1	1.43	1.75	2	2.22	2.72	3.13	4	5.38	6.41	9.09
	J			858.29	1751.61	2641.7	3433.16	4238.47	6365.44	8381.73	13732.63	24808.91	35268.29	70932.99
6	t			1	1.43	1.75	2	2.22	2.72	3.13	4	5.38	6.41	9.09
	J			1107.97	2261.17	3410.2	4431.89	5471.47	8217.2	10820.05	17727.56	32026.03	45528.13	91567.99
8	t			1	1.43	1.75	2	2.22	2.72	3.13	4	5.38	6.41	9.09
	J			1608.38	3282.41	4950.39	6433.53	7942.63	11928.44	15706.85	25734.11	46490.39	66090.63	132924.1
10	t			0.9	1.29	1.58	1.8	2	2.45	2.81	3.6	4.84	5.77	8.18
	J			1670.8	3409.8	5142.51	6683.21	8250.88	12391.38	16316.43	26732.84	48294.67	68655.59	138082.85
12	t			0.9	1.29	1.58	1.8	2	2.45	2.81	3.6	4.84	5.77	8.18
	J			2068.58	4221.58	6366.81	8274.31	10215.19	15341.44	20200.94	33097.23	59792.36	85000.68	170956.75
16	t		0.64	0.9	1	1.23	1.41	1.8	2.42	2.88	4.09			
	J		1293.71	1951.12	2535.67	3130.46	4701.41	6190.61	10142.7	18323.47	26048.6			
20	t	0.45	0.64	0.9	1	1.23	1.41	1.8	2.42	2.88	4.09			
	J	835.4	1704.9	3341.61	4125.44	6195.69	8158.22	13366.42	24147.34	34327.8	69041.43			
24	t	0.45	0.64	0.9	1	1.23	1.41	1.8	2.42	2.88	4.09			
	J	1034.29	2110.79	4137.15	5107.6	7670.72	10100.47	16548.61	29896.18	42500.34	85478.37			
30	t	0.45	0.64	0.9	1	1.23	1.41	1.8	2.42	2.88	4.09			
	J	1328.37	2710.95	5313.46	6559.83	9851.72	12972.32	21253.85	38396.5	54584.38	109782.27			
36	t	0.43	0.53	0.6	0.67	0.82	0.94	1.2	1.61	1.92	2.73			
	J	1407.19	2122.27	2758.1	3405.06	5113.81	6733.65	11032.41	19930.79	28333.56	56985.85			

J = Mass moment of inertia in Kgm²

t = Mechanical index time in seconds (does not include dwell)

All RT Series tables available in servo programmable versions.



MOTION INDEX DRIVES

RT630

For mounted accessories up to \varnothing 6000mm. Applications in assembly facilities with large and heavy parts: welding, riveting, assembling, and printing/labeling.

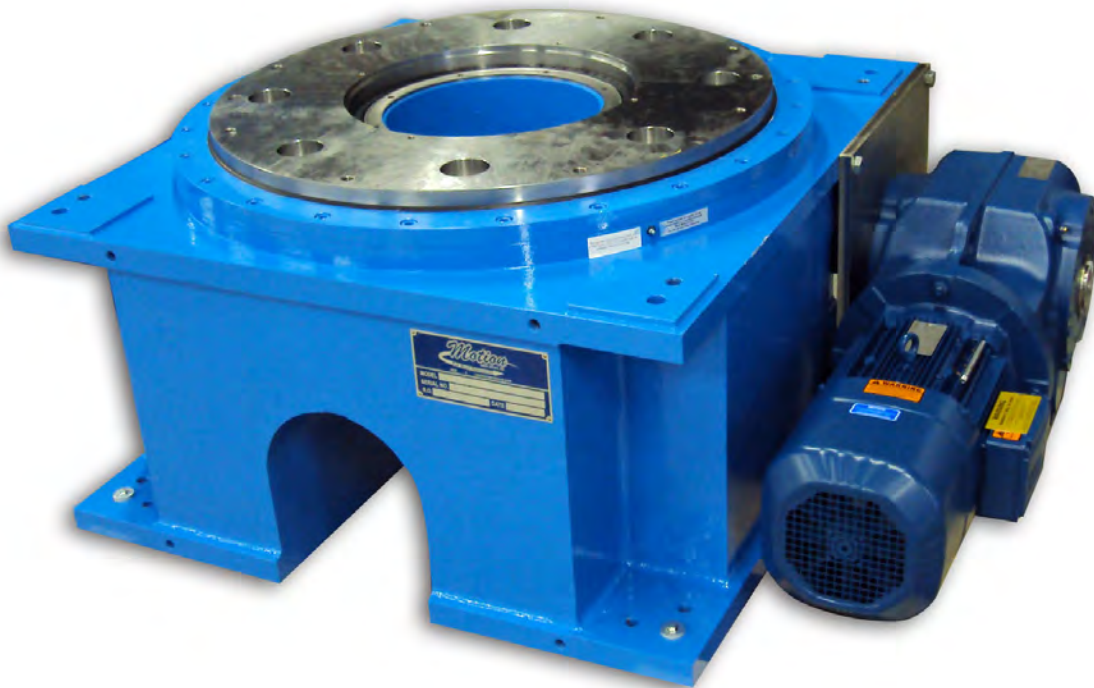

RT630 Technical specifications

Main dimensions

Output flange Ø [mm]	778
Overall height (output flange screw-on surface) [mm]	560
Center opening Ø [mm]	250H8
Recommended max. size of rotating plate Ø [mm]	6000
Index table weight [kg]	1600
Number of indexes	2,3,4,6,8,10,12,16,20,24,30,36
Other numbers on request	

Standard drives

Motor	SEW
Gear unit	SEW
Motor size	71-132
Voltage [V]	ANY
Power [kW]	0.18-7.5

Precision*

Index precision	
In radian measure on cam follower Ø [mm]	±0.023
In angular seconds on cam follower Ø ["]	±15
Axial runout on cam follower Ø [mm]	0.01
Concentricity on cam follower Ø [mm]	0.01

Load on output flange

Axial force Fa [kN]	145
Radial force Fr [kN]	86
Tilting moment Mk [kNm]	41
Reinforced version	
Tilting moment Mk [kNm]	72

Load on central column

Axial force Fa [kN]	80
Tilting moment Mk [kNm]	9

Max. number of cycles [1/min]

Max. number of cycles [1/min]	105
Direction	clockwise, counterclockwise, oscillating
Mounting position	ANY

* The precision is 5 - 8 angular seconds greater at 16 or more indexes due to multiple dwell on the drive cam.

*If required, higher accuracy can be achieved upon request.

Load on output flange

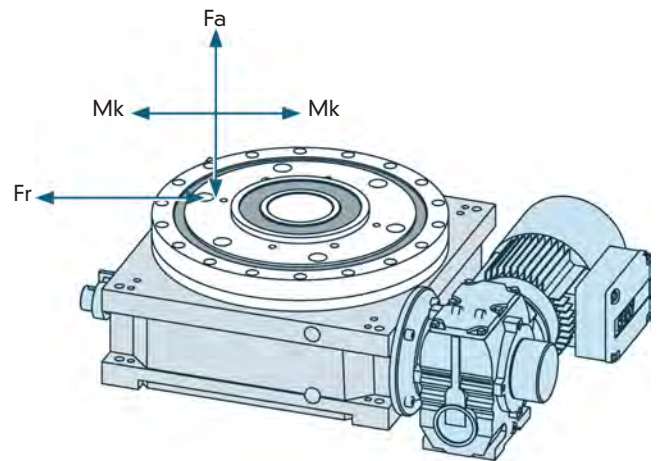

Load on central column

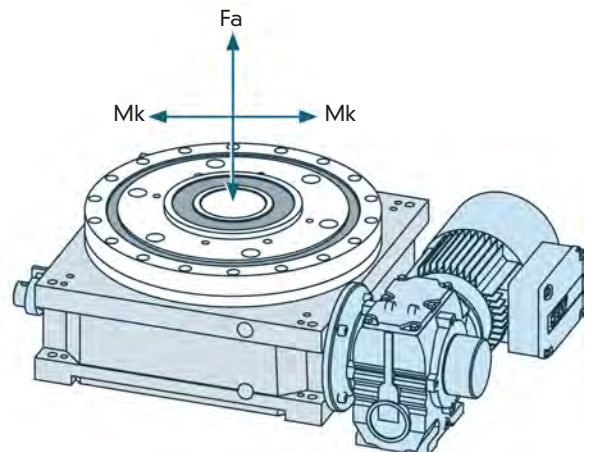

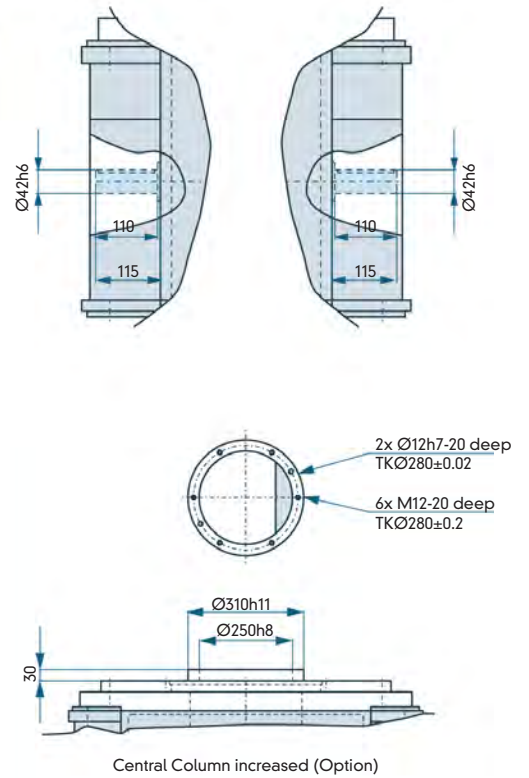
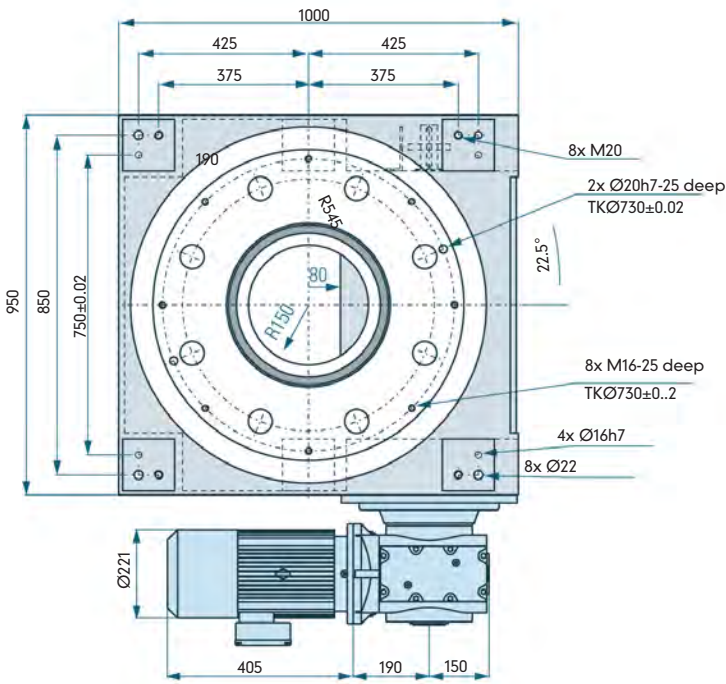
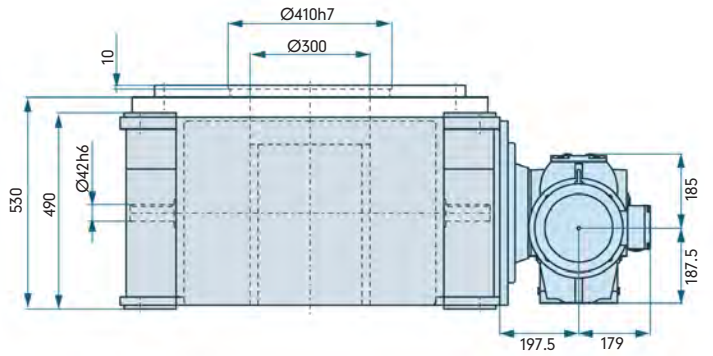
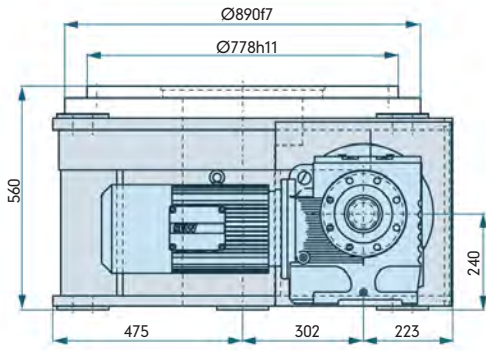

RT630 Dimensions

The dimensions shown here are the standard dimensions. The output flange, central column, housing and input shafts can be machined to your specifications. The central column can also be designed as a flange. Should you wish to drill additional holes, please consult us with regard to acceptable drilling depth.



The dimensions for the gearmotor may change based on the gearmotor size and options required for the application.

A = Length of input shaft

B = Length of shaft to collar

C = Diameter of input shaft

D = Height of central column to supporting surface on output flange

RT630 Load Table

Scenarios

		1	2	3	4	5	6	7	8	9	10	11	12	13
2	t			1.07	1.52	1.87	2.13	2.37	2.9	3.33	4.27	5.73	6.84	9.7
	J			256	523	789	1026	1266	1900	2504	4102	7411	10535	21189
3	t			1	1.43	1.75	2	2.22	2.72	3.13	4	5.38	6.41	9.09
	J			485	989	1492	1939	2394	3595	4734	7756	14011	19918	40060
4	t			1	1.43	1.75	2	2.22	2.72	3.13	4	5.38	6.41	9.09
	J			793.91	1620.22	2443.55	3175.63	3920.53	5887.96	7753.01	12702.53	22947.98	32622.79	65612.25
5	t			1	1.43	1.75	2	2.22	2.72	3.13	4	5.38	6.41	9.09
	J			1162.81	2373.09	3578.99	4651.25	5742.29	8623.92	11355.6	18605.02	33611.21	47781.62	96100.3
6	t			1	1.43	1.75	2	2.22	2.72	3.13	4	5.38	6.41	9.09
	J			1514	3089.79	4659.89	6055.99	7476.54	11228.46	14785.14	24223.98	43762.25	62212.3	125123.85
8	t			1	1.43	1.75	2	2.22	2.72	3.13	4	5.38	6.41	9.09
	J			2496.54	5094.98	7684.02	9986.15	12328.58	18515.39	24380.25	39944.61	72162.62	102586.21	206325.45
10	t			0.9	1.29	1.58	1.8	2	2.45	2.81	3.6	4.84	5.77	8.18
	J			2551.05	5206.22	7851.79	10204.18	12597.76	18919.64	24912.56	4.816.74	73738.18	104826.02	210830.25
12	t			0.9	1.29	1.58	1.8	2	2.45	2.81	3.6	4.84	5.77	8.18
	J			3094.4	6315.1	9524.15	12377.59	15280.97	22949.37	30218.72	49510.35	89443.78	127153.06	255735.29
16	t		0.64	0.9	1	1.23	1.41	1.8	2.42	2.88	4.09			
	J		2128.19	4171.25	5149.7	7733.95	10183.73	16685.02	30142.61	42850.66	86182.95			
20	t	0.45	0.64	0.9	1	1.23	1.41	1.8	2.42	2.88	4.09			
	J	1310.24	2673.97	5240.97	6470.34	9717.32	12795.34	20963.89	30142.61	42850.66	86162.95			
24	t	0.45	0.64	0.9	1	1.23	1.41	1.8	2.42	2.88	4.09			
	J	1576.73	3217.81	6306.92	7786.32	11693.69	15397.74	25227.66	45575.47	64789.98	130308.18			
30	t	0.45	0.64	0.9	1	1.23	1.41	1.8	2.42	2.88	4.09			
	J	1975.48	4031.6	7901.94	9755.48	14651.03	19291.84	31607.75	57101.52	81175.39	163263.17			
36	t	0.43	0.53	0.6	0.67	0.82	0.94	1.2	1.61	1.92	2.73			
	J	21155.62	3251.01	4225.01	5216.06	7833.62	10314.94	16900.05	30531.08	43402.91	87293.64			

J = Mass moment of inertia in Kgm²

t = Mechanical index time in seconds (does not include dwell)

All RT Series tables available in servo programmable versions.



MOTION INDEX DRIVES

RT900

For mounted accessories up to \varnothing 9500mm. Applications in assembly facilities with large and heavy parts: welding, riveting, assembling, and printing/labeling.

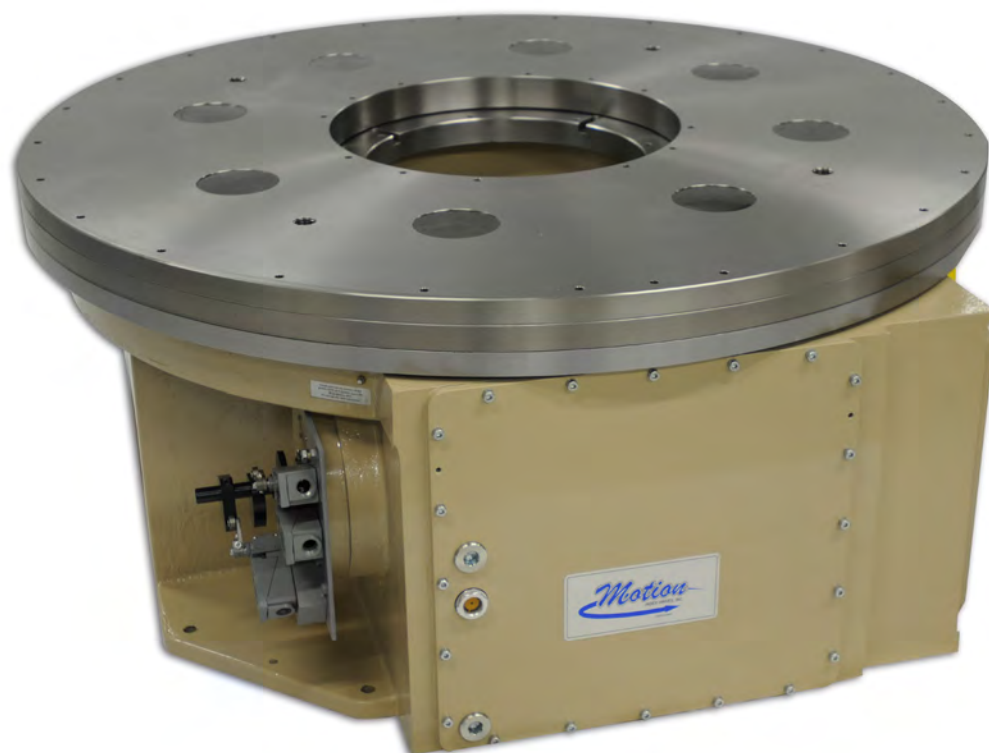

RT900 Technical specifications

Main dimensions

Output flange Ø [mm]	1400
Overall height (output flange screw-on surface) [mm]	611
Center opening Ø [mm]	400H8
Recommended max. size of rotating plate Ø [mm]	9500
Index table weight [kg]	2230
Number of indexes	2,3,4,6,8,10,12,16,20,24,30,36
Other numbers on request	

Standard drives

Motor	SEW
Gear unit	SEW
Motor size	132-160
Voltage [V]	ANY
Power [kW]	5.5-11

Precision*

Index precision	
In radian measure on cam follower Ø [mm]	n/a
angular seconds Ø ["]	n/a
Axial runout on cam follower Ø [mm]	n/a
Concentricity on cam follower Ø [mm]	n/a

Load on output flange

Axial force Fa [kN]	n/a
Radial force Fr [kN]	n/a
Tilting moment Mk [kNm]	n/a
Reinforced version	
Tilting moment Mk [kNm]	n/a

Load on central column

Axial force Fa [kN]	n/a
Tilting moment Mk [kNm]	n/a

Max. number of cycles [1/min]

n/a

Direction clockwise, counterclockwise, oscillating

Mounting position ANY

* The precision is 5 - 8 angular seconds greater at 16 or more indexes due to multiple dwell on the drive cam.

*If required, higher accuracy can be achieved upon request.

Load on output flange

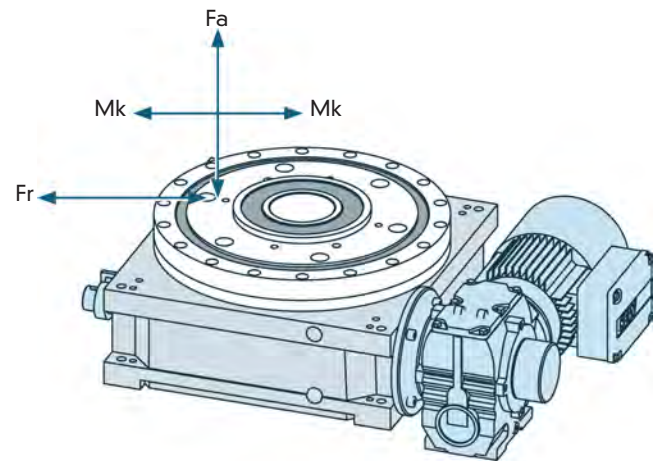

Load on central column

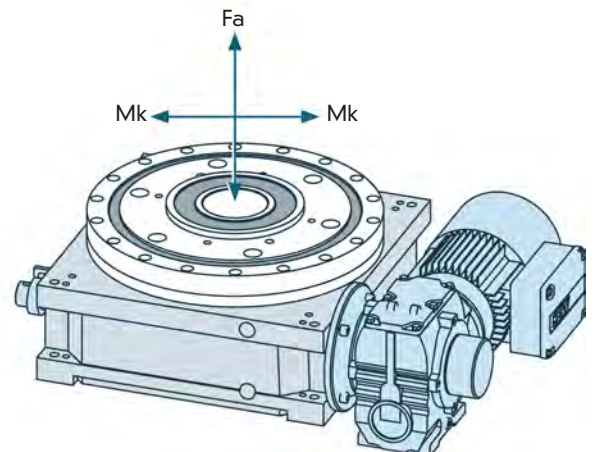

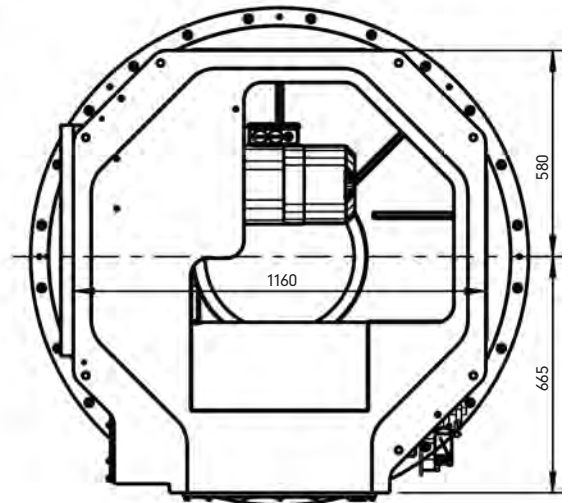
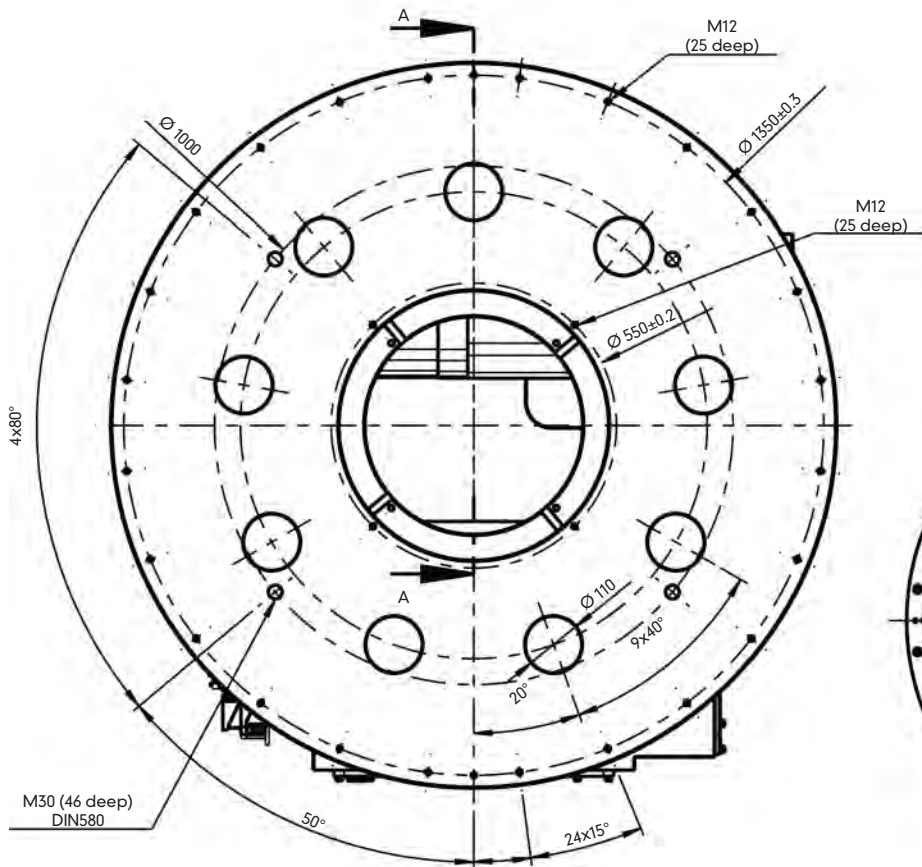
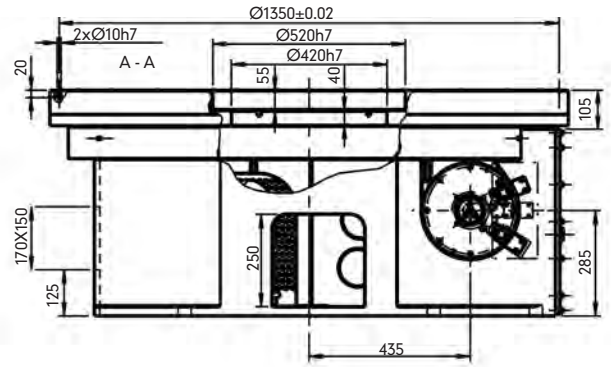
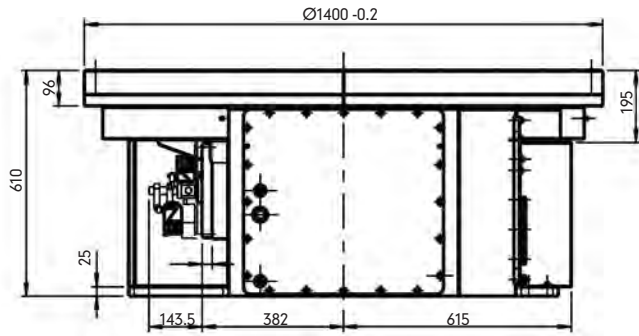

R900 Dimensions

The dimensions shown here are the standard dimensions. The output flange, central column, housing and input shafts can be machined to your specifications. The central column can also be designed as a flange. Should you wish to drill additional holes, please consult us with regard to acceptable drilling depth.



The dimensions for the gearmotor may change based on the gearmotor size and options required for the application.



MOTION INDEX DRIVES

ROTARY INDEX TABLES
TT Series

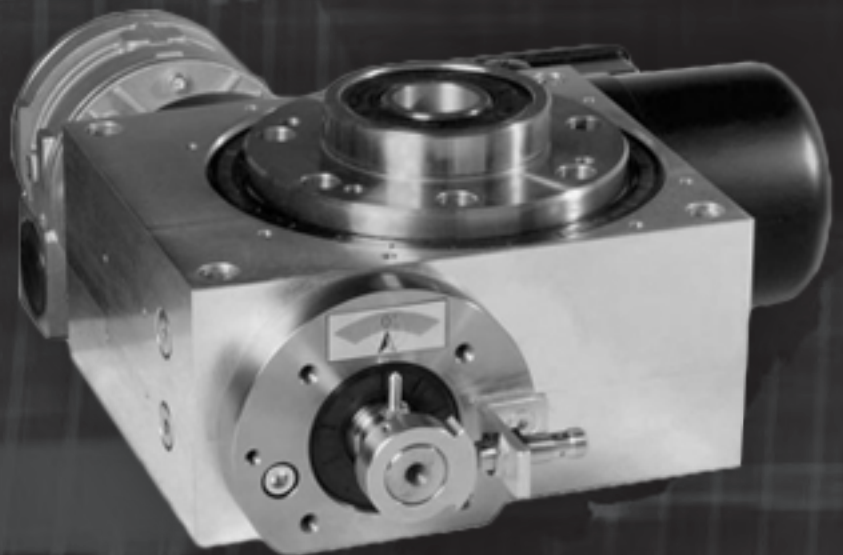



MOTION INDEX DRIVES

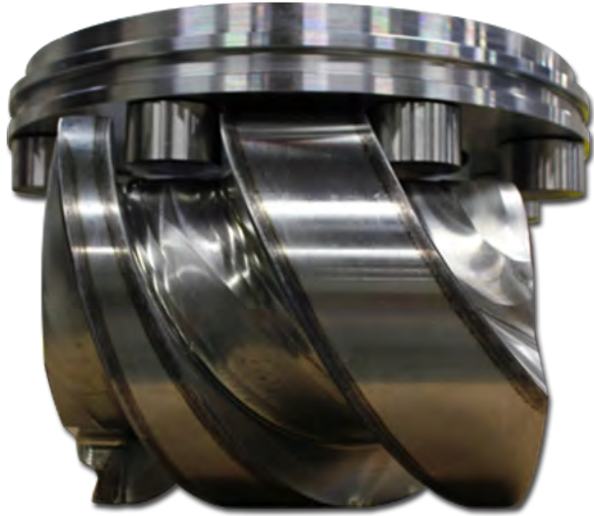

Advantages for design engineers and special machine builder

- Housing machined on all sides. Suitable for use in any mounting position required.
- Mounting holes identical on top and bottom.
- Large center thru-hole which is large enough to feed entire shafts through, and not just small wiring looms.
- Dowel holes in housing and in output flange.
- Recessed center column. No obstruction. Lengthened and machined to customer requirements.
- Simultaneously rotating input shaft extension. Optional synchronization of other mechanical modules.

Options for individual customer requirements

- Choice of drive unit/gear motor.
- Reinforced output flange bearing for higher tilting moment.
- Optional friction clutch on drive
- Dwell and index angle can be tailored to requirements.
- All sizes also available as programmable index tables.
- Custom specified color at no extra charge.

Technical benefits for users

- High reliability and long service life.
- Robust method of construction.
- Hardened cams: smaller sizes for higher load factors.
- Bearings fully immersed in oil bath.
- Cam followers self lubricating through oil bath.
- No wear. Completely maintenance-free.

Fixed Index Drives

The rotary index table transforms a constant input drive motion into an intermittent output drive motion. The intermittent drive motion occurs by means of a hardened and high accuracy barrel cam. The use of mathematical laws of motion guarantees a soft, shock-proof, and jerk free movement that has been optimally designed for its intended purpose. The design allows for accurate and secure mounting to the output dial. The preload of the cam to the cam followers in dwell ensures the top dial is backlash free. No additional adjustment of the output dial is necessary.

The power is provided either by means of a three-phase motor via a gear reducer or by means of a timing chain/belt on the drive shaft of the rotary index table. This is firmly connected to the barrel cam without any further internal gear sets, and it turns the cam followers and subsequently the output flange. The output dial is mounted to a wire bearing assembly (4 point contact bearing), which is preloaded to eliminate any runout. The index drive is completely sealed to eliminate intrusion from foreign particulate.

Programmable Index Drives

The rotary index table transforms a constant input drive motion into a constant output drive motion. The drive motion occurs by means of a hardened and high-accuracy constant lead barrel cam. The use of mathematical laws of motion along with a properly programmed motor profile guarantee a soft, shock proof, and jerk free movement that has been optimally designed for its intended purpose. The design allows for accurate and secure mounting to the output dial. The preload of the cam to the cam followers in dwell ensures the top dial is backlash free. No additional adjustment of the output dial is necessary.

The power to rotate the index drive is provided either by means of a three phase AC motor with encoder, coupled to a gear reducer, or a servo motor coupled to a gear reducer. The gear reducer is connected to the input shaft which is firmly connected to the internal barrel cam with no further internal gearing. The barrel cam in turn rotates the top dial through the cam followers with a zero backlash internal design. The output dial is mounted to a wire bearing assembly (4 point contact bearing), which is preloaded to eliminate any runout. The index drive is completely sealed to eliminate intrusion from foreign particulate.

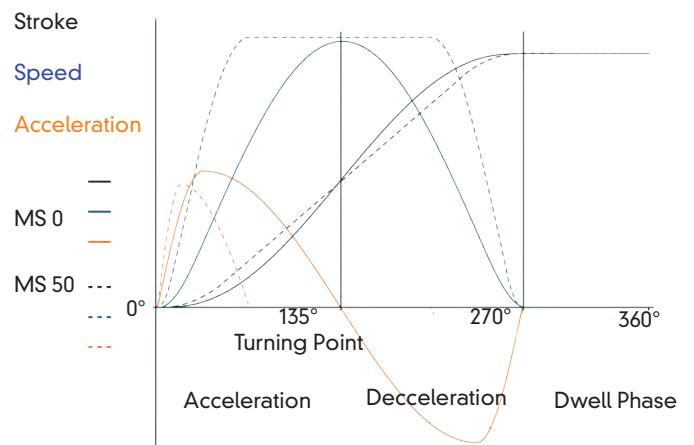

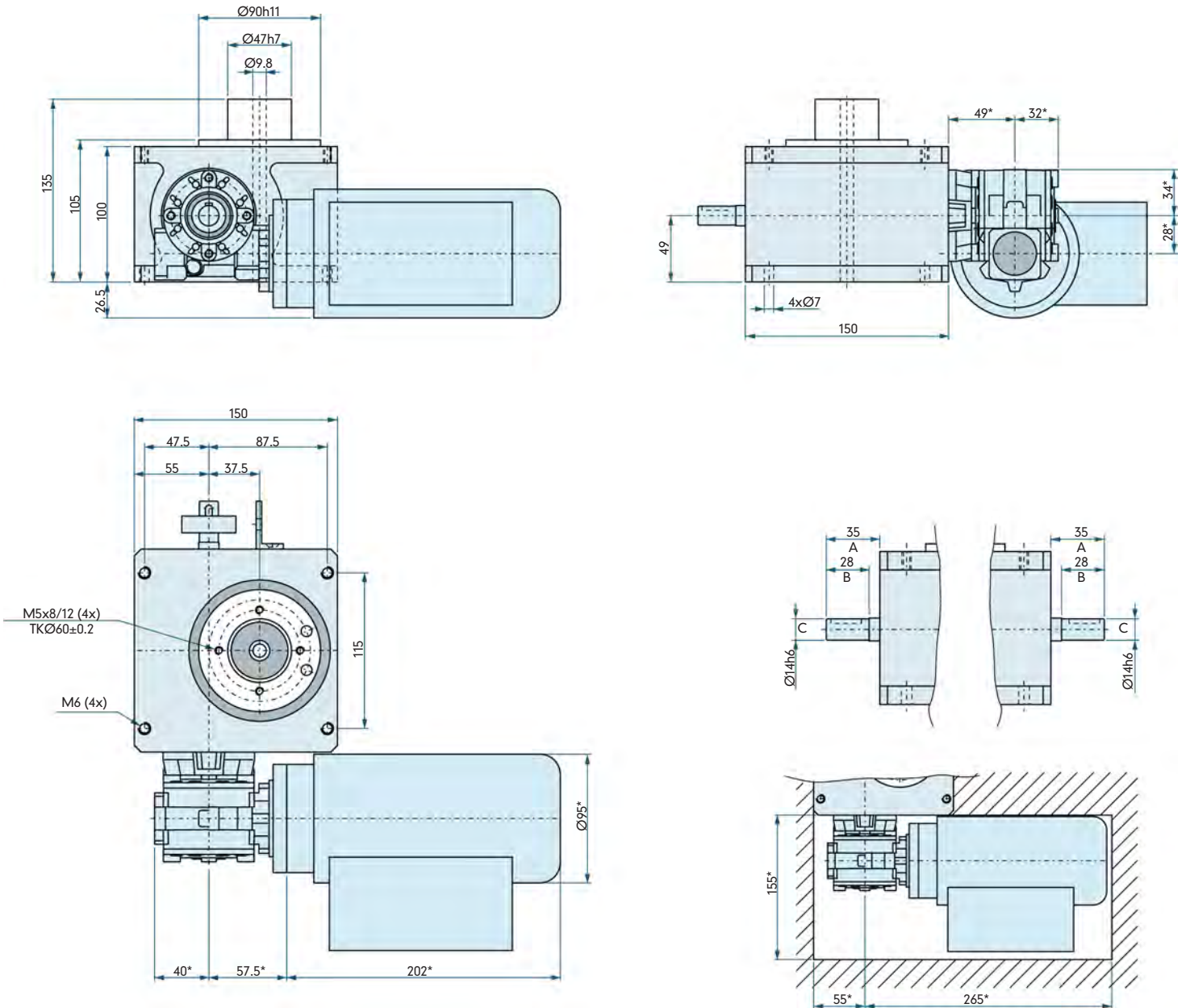

TT075 Dimensions

The dimensions shown here are the standard dimensions. The output flange, central column, housing and input shafts can be machined to your specifications. The central column can also be designed as a flange. Should you wish to drill additional holes, please consult us with regard to acceptable drilling depth.

- A = Length of input shaft
- B = Length of shaft to collar
- C = Diameter of input shaft



The dimensions for the gearmotor may change based on the gearmotor size and options required for the application.

TT075 Load Table

Scenarios

		1	2	3	4	5	6	7	8	9
2	t			0.38	0.57	0.76	1.07	1.52	1.87	2.13
	J			0.35	0.79	0.97	1.9	3.87	5.84	7.59
3	t			0.36	0.54	0.71	1	1.43	1.75	2
	J			0.57	1.29	1.97	3.86	7.87	11.87	15.42
4	t			0.36	0.54	0.71	1	1.43	1.75	2
	J			0.83	1.87	2.85	5.59	11.42	17.22	22.38
5	t			0.36	0.54	0.71	1	1.43	1.75	2
	J			1.04	2.35	4.18	8.19	16.71	25.2	32.75
6	t			0.36	0.54	0.71	1	1.43	1.75	
	J			1.35	3.04	5.4	10.58	21.59	32.57	
8	t			0.36	0.54	0.71	1	1.43	1.75	
	J			1.96	4.42	7.85	15.38	31.39	47.34	
10	t			0.32	0.48	0.64	0.9	1.29	1.58	
	J			20.4	4.59	8.16	15.98	32.62	49.2	
12	t			0.32	0.48	0.64	0.9	1.29	1.58	
	J			2.53	5.69	10.1	19.8	40.41	60.95	
16	t	0.16	0.24	0.32	0.45	0.64	0.79	0.9	1	
	J	0.77	1.74	3.09	6.06	12.37	18.65	24.24	29.92	
20	t	0.16	0.24	0.32	0.45	0.64	0.79	0.9	1	
	J	1.02	2.3	4.08	7.99	16.31	24.6	31.97	39.47	
24	t	0.16	0.24	0.32	0.45	0.64	0.79	0.9	1	
	J	1.26	2.84	5.05	9.9	20.21	30.47	39.6	48.89	
30	t	0.16	0.24	0.32	0.45	0.64	0.79	0.9	1	
	J	1.62	3.65	6.49	12.72	25.97	39.16	50.89	62.83	
36	t	0.11	0.16	0.21	0.3	0.43	0.53	0.6	0.67	
	J	0.84	1.9	3.37	6.6	13.47	20.32	26.4	32.6	

Technical Specifications

Main Dimensions

Output Flange Ø [mm]	90
Overall Height [mm]	105
Center Opening Ø [mm]	9.8
Max. size of rotating plate Ø [mm]	500
# of indexes	2,3,4,6,8,10,12,16,20,24,30,36 (other numbers on request)
Index Table weight [kg]	12
Direction	CW, CCW, oscillating
Mounting Position	ANY

Load on output flange

Axial force [kN]	1.5
Radial force [kN]	0.6
Tilting moment [kNm]	0.5

Load on Central column

Axial force [kN]	0.5
Tilting moment [kNm]	0.04

Precision

Index precision ["]	±28
Axial Runout [mm]	±0.01
Radial Runout [mm]	±0.01

Standard Drive

Motor	SEW
Gear unit	SEW
Motor size	56
Voltage [V]	ANY
Power [kW]	0.06-0.09

* The precision is 5 - 8 angular sec-onds greater at 16 or more indexes due to multi-ple dwell positions on the drive cam.

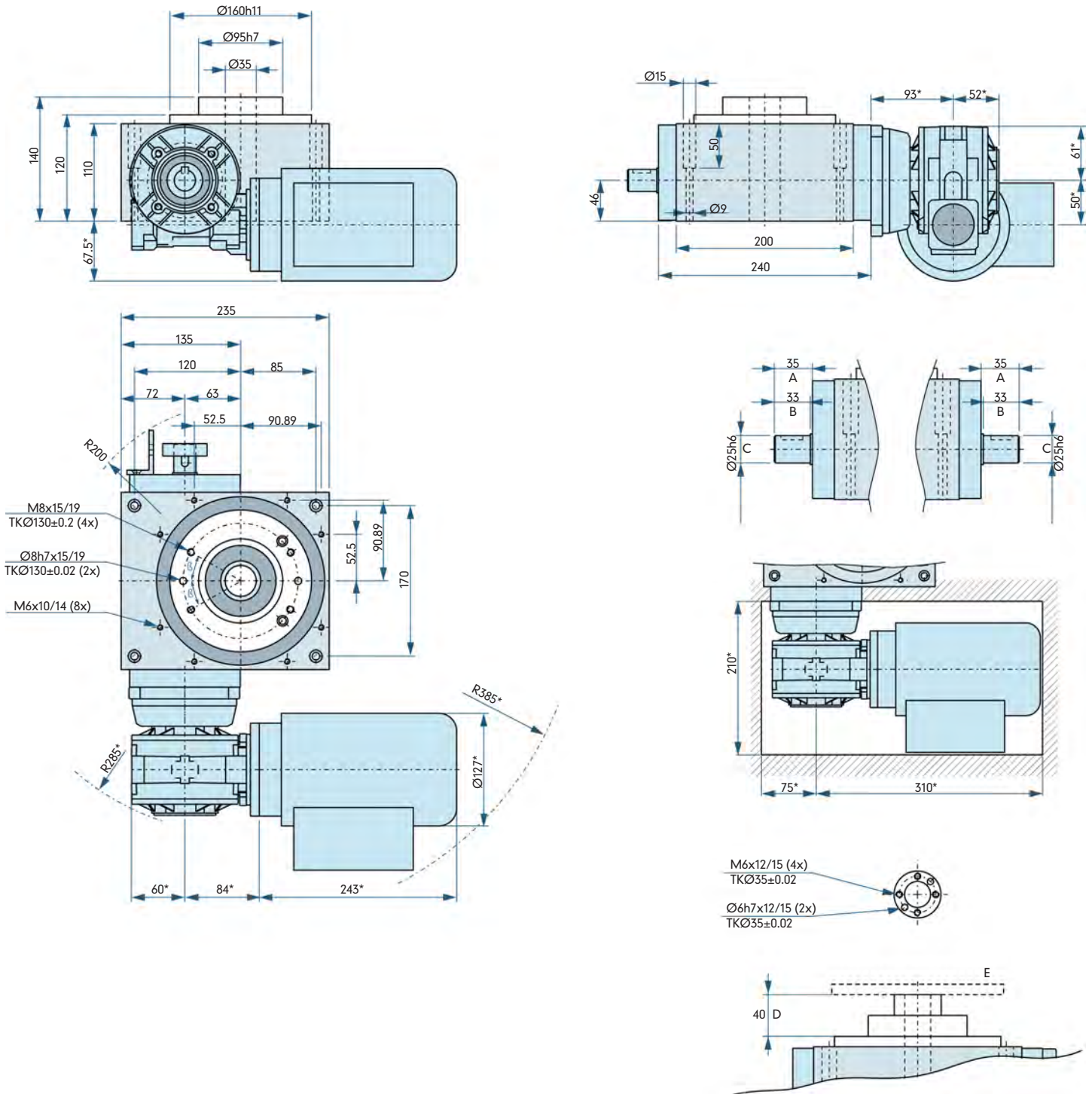

TT125 Dimensions

The dimensions shown here are the standard dimensions. The output flange, central column, housing and input shafts can be machined to your specifications. The central column can also be designed as a flange. Should you wish to drill additional holes, please consult us with regard to acceptable drilling depth.



The dimensions for the gearmotor may change based on the gearmotor size and options required for the application.

A = Length of input shaft

B = Length of shaft to collar

C = Diameter of input shaft

D = Height of central column to supporting surface on output flange, standard is -0.5mm

E = Flange plate as an option

TT125 Load Table

Scenarios

		1	2	3	4	5	6	7	8	9	10	11
2	t			0.57	0.76	1.07	1.52	1.87	2.13	2.37	2.9	3.33
	J			1.5	2.02	3.96	8.08	12.18	15.83	19.55	29.36	38.66
3	t			0.54	0.71	1	1.43	1.75	2	2.22	2.72	
	J			2.79	4.26	8.34	17.02	25.67	33.36	41.19	61.86	
4	t		0.36	0.54	0.71	1	1.43	1.75	2	2.22	2.72	
	J		1.83	4.13	6.3	12.35	25.21	38.02	49.41	61	91.62	
5	t		0.36	0.54	0.71	1	1.43	1.75	2	2.22	2.72	
	J		2.31	5.2	9.24	18.12	36.97	55.76	72.47	89.46	134.36	
6	t		0.36	0.54	0.71	1	1.43	1.75	2	2.22	2.72	
	J		3.05	6.88	12.21	23.94	48.86	73.68	95.76	118.22	177.55	
8	t		0.36	0.54	0.71	1	1.43	1.75	2			
	J		4.58	10.32	18.34	35.94	73.36	110.63	143.78			
10	t		0.32	0.48	.064	0.9	1.29	1.58	1.8			
	J		4.82	10.85	19.28	37.79	77.11	116.3	151.14			
12	t		0.32	0.48	0.64	0.9	1.29	1.58				
	J		6.06	13.65	24.25	47.53	96.99	146.28				
16	t	0.24	0.32	0.45	0.64	0.79	0.9	1				
	J	4.02	7.14	14	28.58	43.1	56.01	69.15				
20	t	0.24	0.32	0.45	0.64	0.79	0.9	1				
	J	5.43	9.64	18.89	35.56	58.15	75.57	93.3				
24	t	0.24	0.32	0.45	0.64	0.79	0.9	1				
	J	6.82	12.12	23.76	48.5	73.14	95.05	117.35				
30	t	0.24	0.32	0.45	0.64	0.79	0.9	1				
	J	8.9	15.81	30.98	63.22	95.35	123.91	152.98				
36	t	0.16	0.21	0.3	0.43	0.53	0.6	0.67	0.82			
	J	4.55	8.08	15.84	32.33	48.76	63.37	78.23	117.49			

Technical Specifications

Main Dimensions

Output Flange Ø [mm]	160
Overall Height [mm]	120
Center Opening Ø [mm]	35
Max. size of rotating plate Ø [mm]	1000
# of indexes	2,3,4,6,8,10,12,16,20,24,30,36 (other numbers on request)
Index Table weight [kg]	24
Direction	CW, CCW, Reversing
Mounting Position	ANY

Load on output flange

Axial force [kN]	6
Radial force [kN]	2.8
Tilting moment [kNm]	0.2

Load on Central column

Axial force [kN]	3
Tilting moment [kNm]	0.2

Precision

Index precision ["]	±20
Axial Runout [mm]	±0.015
Radial Runout [mm]	±0.015

Standard Drive

Motor	SEW
Gear unit	SEW
Motor size	71
Voltage [V]	ANY
Power [kW]	0.12-0.55

* The precision is 5 - 8 angular sec-onds greater at 16 or more indexes due to multi-ple dwell positions on the drive cam.

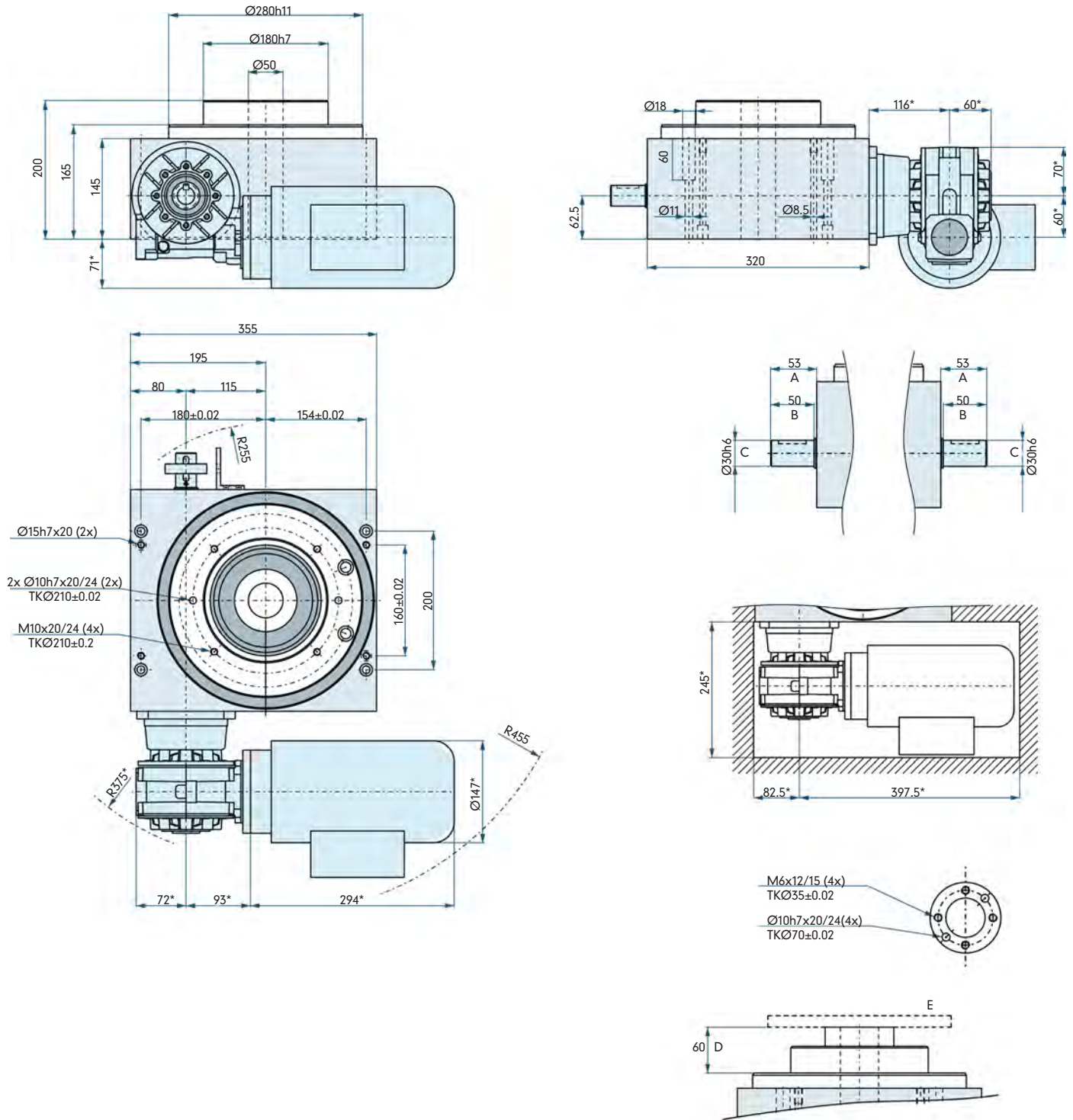

TT250 Dimensions

The dimensions shown here are the standard dimensions. The output flange, central column, housing and input shafts can be machined to your specifications. The central column can also be designed as a flange. Should you wish to drill a additional holes, please consult us with regard to acceptable drilling depth.



The dimensions for the gearmotor may change based on the gearmotor size and options required for the application.

A = Length of input shaft

B = Length of shaft to collar

C = Diameter of input shaft

D = Height of central column to supporting surface on output flange, standard is -0.5mm

E = Flange plate as an option

TT250 Load Table

Scenarios

		1	2	3	4	5	6	7	8	9	10	11	12
2	t			0.57	0.76	1.07	1.52	1.87	2.13	2.37	2.9	3.33	4.27
	J			3.9	4.78	9.38	19.14	28.86	37.51	46.31	69.55	91.58	150.05
3	t			0.54	0.71	1	1.43	1.75	2	2.22	2.72	3.13	
	J			6.8	10.39	20.37	41.58	62.7	81.49	100.61	151.09	198.95	
4	t		0.32	0.48	0.64	0.9	1.29	1.58	1.8	2	2.45	2.81	
	J		3.42	7.71	11.78	23.09	47.12	71.06	92.35	114.01	171.22	225.45	
5	t		0.32	0.48	0.64	0.9	1.29	1.58	1.8	2	2.45	2.81	
	J		4.33	9.75	17.32	33.94	69.27	104.47	135.77	167.62	251.73	331.47	
6	t		0.32	0.48	0.64	0.9	1.29	1.58	1.8	2	2.45		
	J		5.9	13.29	23.61	46.28	94.44	142.44	185.11	228.53	343.21		
8	t		0.32	0.48	0.64	0.9	1.29	1.58	1.8				
	J		9.34	21.02	37.34	73.19	149.37	225.27	292.76				
10	t		0.32	0.48	0.64	0.9	1.29	1.58	1.8				
	J		12.95	29.16	51.81	101.55	207.24	312.56	406.2				
12	t		0.32	0.48	0.64	0.9	1.29	1.58	1.8				
	J		16.63	37.44	66.51	130.35	266.03	401.21	521.41				
16	t	0.24	0.32	0.45	0.64	0.79	0.9	1	1.23				
	J	10.51	18.67	36.59	74.68	112.63	146.38	180.71	271.4				
20	t	0.24	0.32	0.45	0.64	0.79	0.9	1	1.23				
	J	14.58	25.91	50.77	103.62	156.28	203.1	250.74	376.57				
24	t	0.24	0.32	0.45	0.64	0.79	0.9	1	1.23				
	J	18.72	33.25	65.18	133.01	200.61	260.71	321.86	483.38				
30	t	0.24	0.32	0.45	0.64	0.79	0.9	1					
	J	24.91	44.26	86.75	177.04	267.01	347	428.4					
36	t	0.16	0.21	0.3	0.43	0.53	0.6	0.67	0.82	0.94			
	J	12.48	22.17	43.45	88.68	133.74	173.8	214.57	322.25	424.33			

Technical Specifications

Main Dimensions

Output Flange Ø [mm]	280
Overall Height [mm]	165
Center Opening Ø [mm]	50
Max. size of rotating plate Ø [mm]	2000
# of indexes	2,3,4,6,8,10,12,16,20,24,30,36 (other numbers on request)
Index Table weight [kg]	77
Direction	CW, CCW, oscillating
Mounting Position	ANY

Load on output flange

Axial force [kN]	23
Radial force [kN]	24
Tilting moment [kNm]	2

Load on Central column

Axial force [kN]	12
Tilting moment [kNm]	2

Precision

Index precision ["]	±25
Axial Runout [mm]	±0.01
Radial Runout [mm]	±0.01

Standard Drive

Motor	SEW
Gear unit	SEW
Motor size	71-90
Voltage [V]	ANY
Power [kW]	0.18-1.5

* The precision is 5 - 8 angular sec-onds greater at 16 or more indexes due to multi-ple dwell positions on the drive cam.

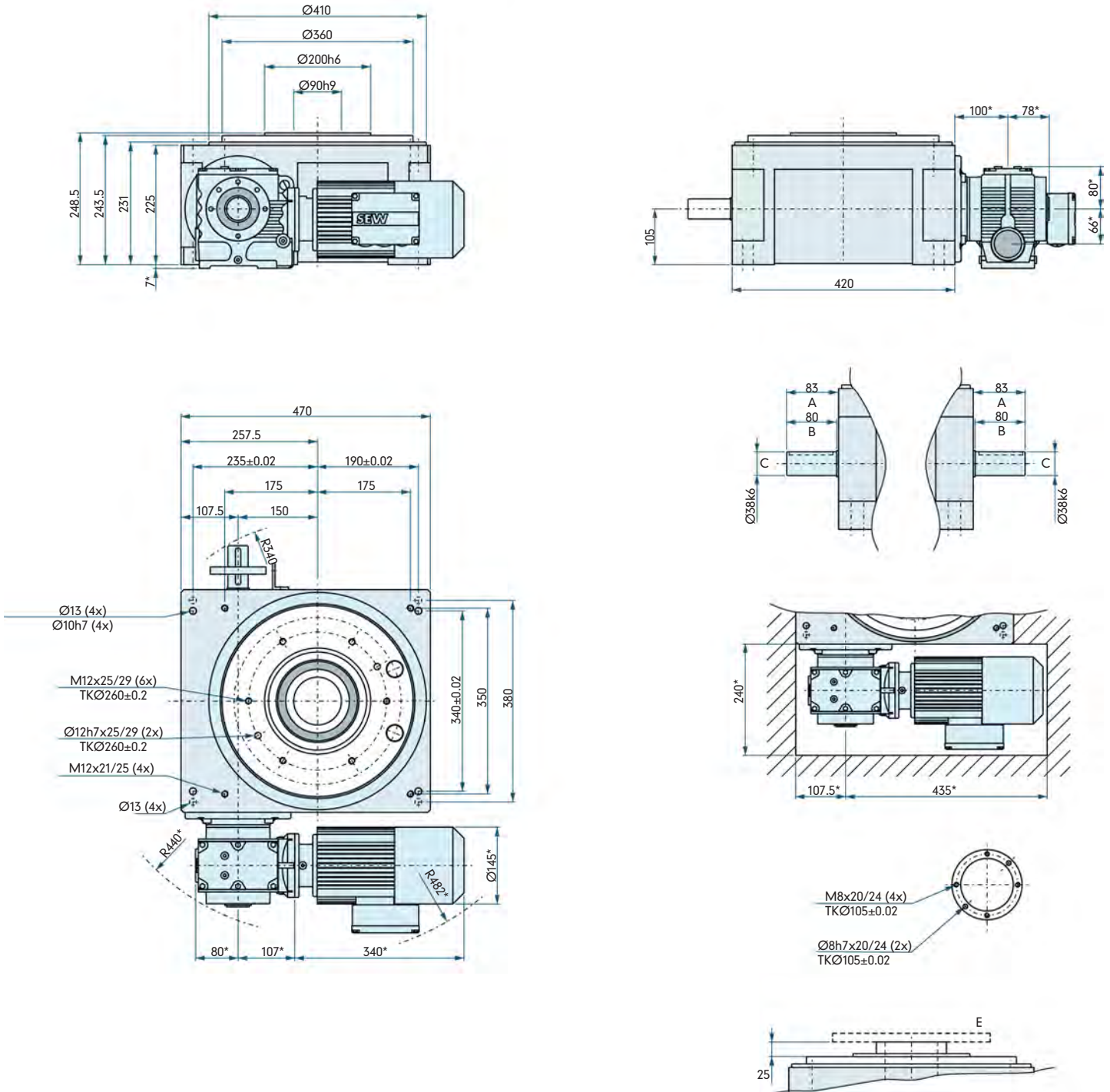

TT315 Dimensions

The dimensions shown here are the standard dimensions. The output flange, central column, housing and input shafts can be machined to your specifications. The central column can also be designed as a flange. Should you wish to drill additional holes, please consult us with regard to acceptable drilling depth.



The dimensions for the gearmotor may change based on the gearmotor size and options required for the application.

A = Length of input shaft

B = Length of shaft to collar

C = Diameter of input shaft

D = Height of central column to supporting surface on output flange, standard is -0.5mm

E = Flange plate as an option

TT315 Load Table

Scenarios

		1	2	3	4	5	6	7	8	9	10	11	12
2	t		0.38	0.59	0.78	1.13	1.56	1.77	2.06	2.38	2.97	3.27	4.13
	J		2.65	9.8	16.5	45	89	115	180	210	348	463	630
3	t		0.36	0.54	0.73	1	1.49	1.65	1.94	2.23	2.79	3.07	3.87
	J		5.3	20	33	92	175	238	365	427	698	940	1270
4	t	0.24	0.32	0.5	0.65	0.95	1.34	1.48	1.75	2	2.51	2.76	3.48
	J	2.95	7	23	42	102	225	295	420	552	920	1190	1650
5	t	0.24	0.32	0.5	0.65	0.95	1.34	1.48	1.75	2	2.51	2.76	3.48
	J	4.4	10.5	33	61	152	325	415	598	825	1370	1720	2450
6	t	0.24	0.32	0.5	0.65	0.95	1.34	1.48	1.75	2	2.51	2.76	3.48
	J	6.45	14.5	46	81.5	178	440	550	790	1095	1850	2320	3520
8	t	0.24	0.32	0.5	0.65	0.95	1.35	1.48	1.75	2	2.45	2.8	
	J	11.5	23.5	67	123	295	660	815	1220	1650	2610	3560	
10	t	0.24	0.32	0.5	0.65	0.95	1.35	1.48	1.78	2.05	2.45	2.84	
	J	16.5	33.2	90.5	167	395	890	1130	1570	2300	3460	4850	
12	t	0.24	0.32	0.5	0.65	0.95	1.35	1.51	1.78	2.17	2.48		
	J	22.1	42.5	110	216	510	1100	1420	2170	3025	4400		
16	t			0.25	0.33	0.47	0.67	0.74	0.88	1	1.21		
	J			47	81	206	375	455	645	720	1250		
20	t			0.25	0.33	0.47	0.67	0.74	0.89	1	1.24		
	J			64	110	230	460	570	760	1065	1520		
24	t			0.25	0.33	0.47	0.67	0.76	0.91	1.1	1.37		
	J			78	133	257	560	710	995	1340	2310		
30	t			0.25	0.33	0.47	0.72	0.78	0.9	1.1	1.37		
	J			95	163	345	790	940	1270	1910	2880		
36	t			0.25	0.37	0.5	0.71	0.93	1.18	1.48			
	J			113	253	451	940	1610	2380	4190			

Technical Specifications

Main Dimensions

Output Flange Ø [mm]	360
Overall Height [mm]	243.5
Center Opening Ø [mm]	90
Max. size of rotating plate Ø [mm]	2800
# of indexes	2,3,4,6,8,10,12,16,20,24,30,36 (other numbers on request)
Index Table weight [kg]	193
Direction	CW, CCW, oscillating
Mounting Position	ANY

Load on output flange

Axial force [kN]	32
Radial force [kN]	17
Tilting moment [kNm]	5

Load on Central column

Axial force [kN]	28
Tilting moment [kNm]	4

Precision

Index precision ["]	±23
Axial Runout [mm]	±0.01
Radial Runout [mm]	±0.01

Standard Drive

Motor	SEW
Gear unit	SEW
Motor size	71-100
Voltage [V]	ANY
Power [kW]	0.37-2.2

* The precision is 5 - 8 angular sec-onds greater at 16 or more indexes due to multiple dwell positions on the drive cam.



MOTION INDEX DRIVES

RING INDEX DRIVES
TSR Series



TSR600 Dimensions

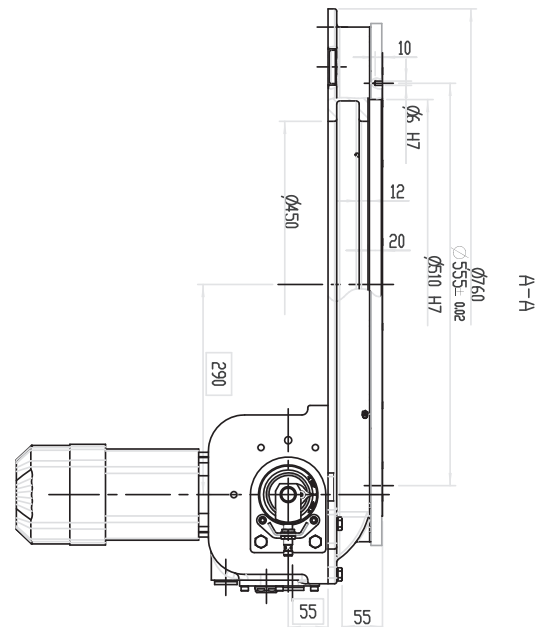
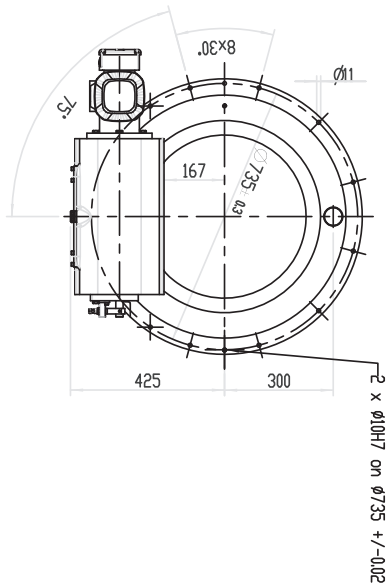
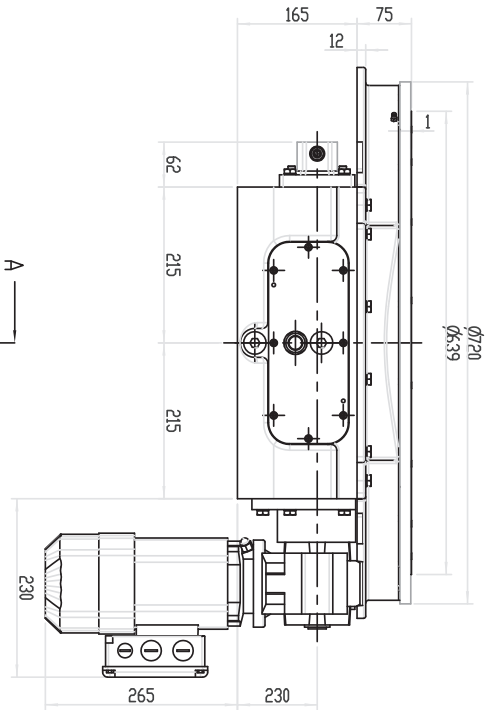
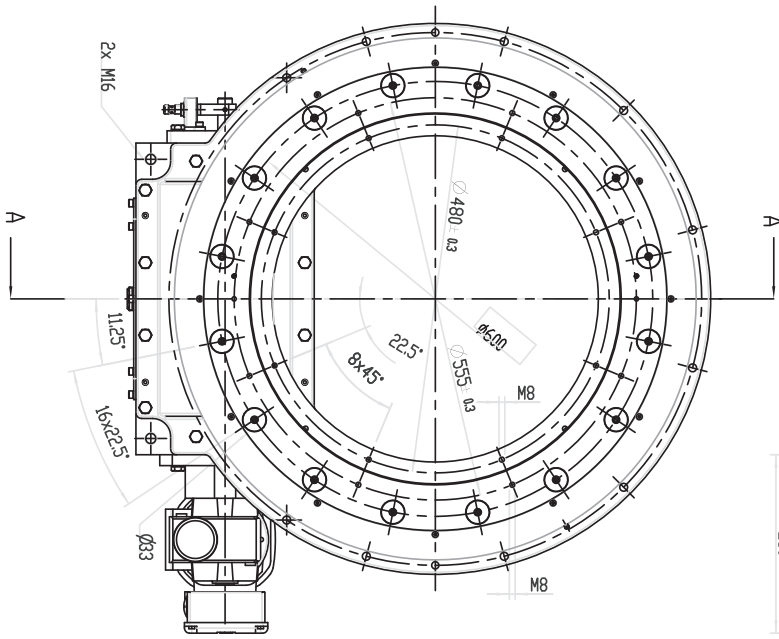

The dimensions for the gearmotor may change based on the gearmotor size and options required for the application.

TSR1000 Dimensions

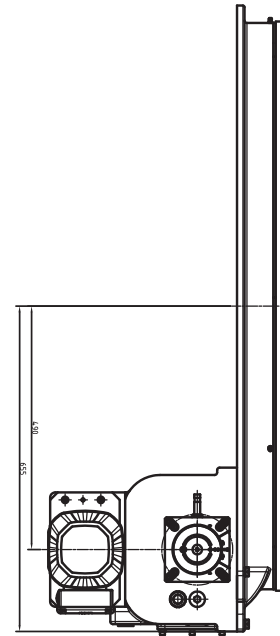
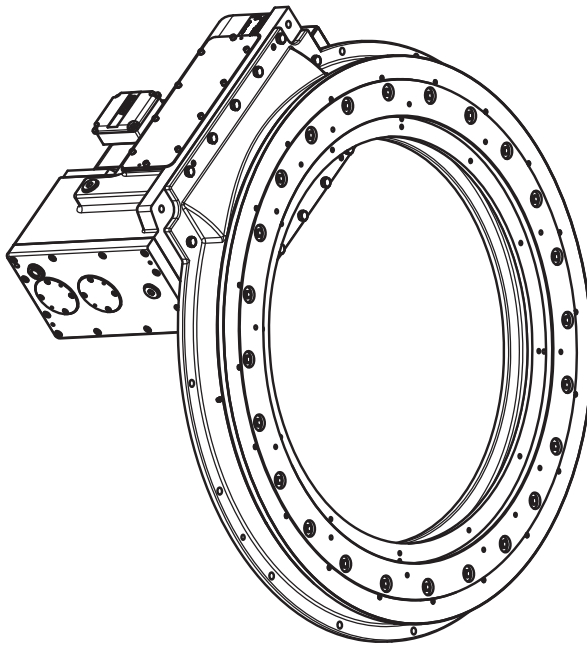
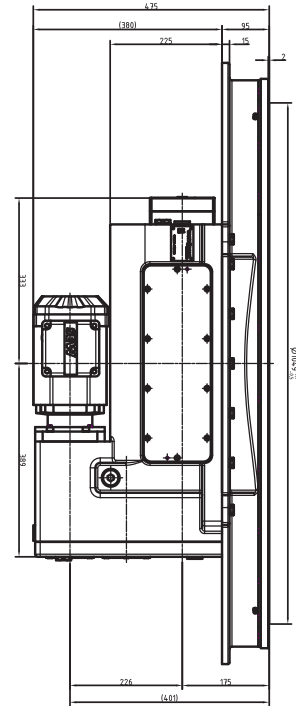
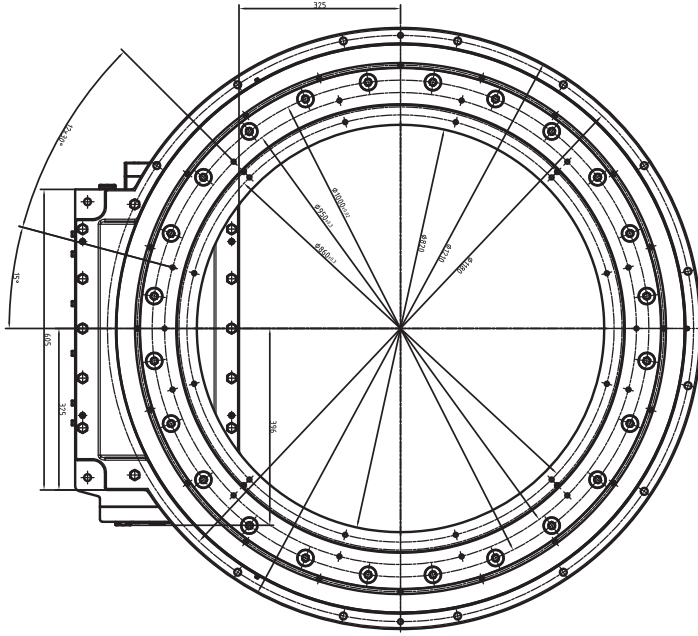

The dimensions for the gearmotor may change based on the gearmotor size and options required for the application.

TSR1400 Dimensions

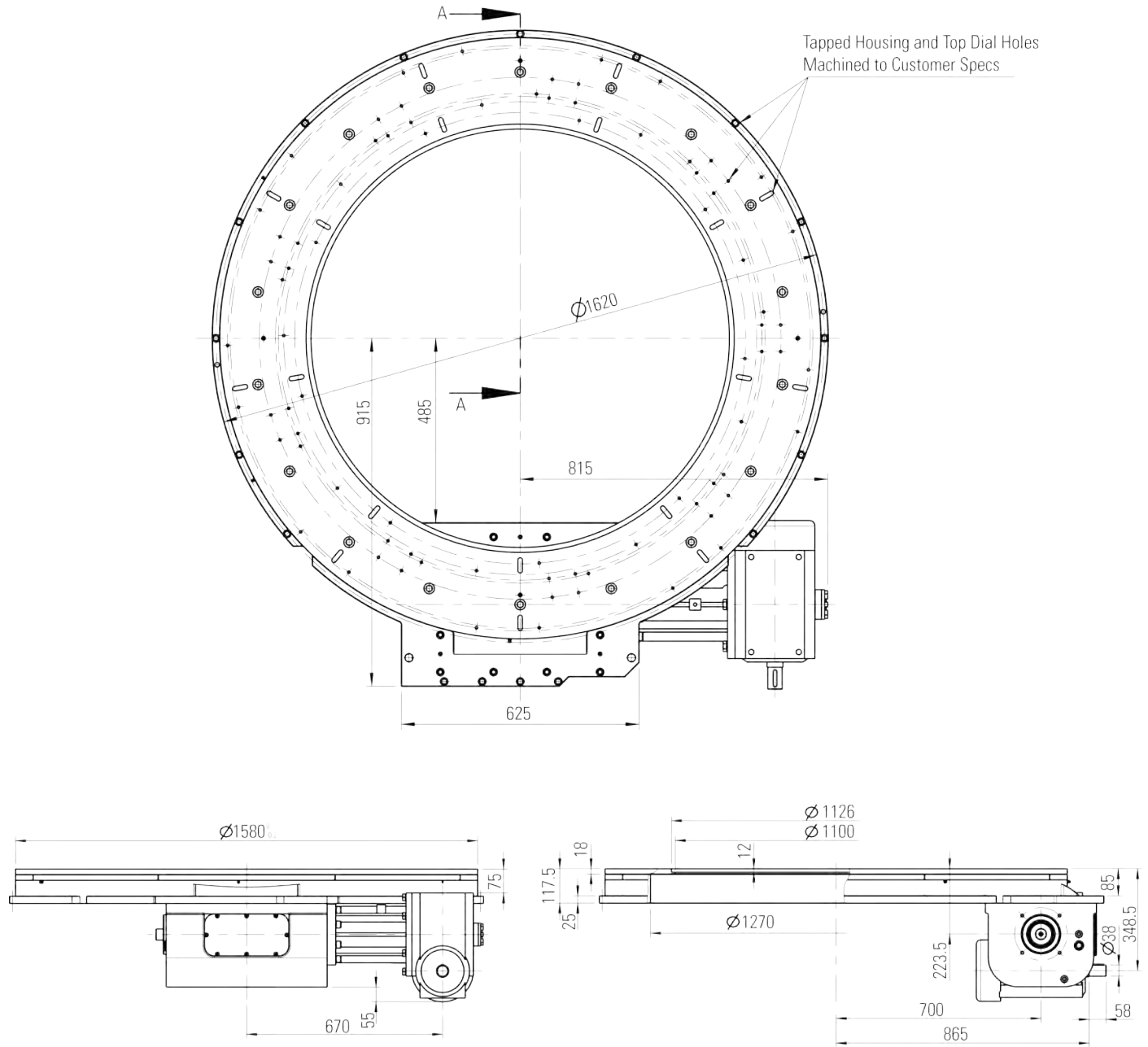

The dimensions for the gearmotor may change based on the gearmotor size and options required for the application.



MOTION INDEX DRIVES

PARALLEL INDEX DRIVES XP Series



Calculations

J = moment of inertia

$$M_B = c_a \times n \frac{2\pi}{n \times t^2}$$

$$M_R = \mu \times g \times R \times m$$

$$M_{AB} = M_B + M_R + (M_{ST})^*$$

$$M_{ST} = m \times g \times R$$

$$M_{AN} = ((M_B \times c_m) + (M_{ST} \times C_v)) \times \frac{360^\circ}{n \times a}$$

$$P = \frac{M_{AN} \times f_a}{9550 \times n}$$

*with one-sided lifting of loads

J = moment of inertia [kgm²]

M_B = acceleration torque [Nm]

M_R = friction torque [Nm]

M_{AB} = indexer torque [Nm]

M_{ST} = static torque [Nm]

M_{AN} = drive torque [Nm]

μ = friction coefficient

g = acceleration of gravity = 9,81m/s²

R = radius

m = mass [kg]

a = switching angle [°]

t_s = index time [s]

n = number of stops

i = ratio

P = drive power [kW]

n = efficiency worm gear

f_a = drive speed [1/min]

MS = ACCELERATION	MS0	MS30	M250
c _a = acceleration coefficient	5.53	6.41	8.01
c _m = performance coefficient	0.99	0.81	0.72
c _v = speed coefficient	1.76	1.43	1.27

Sorting and Isolation

$$M_{AB} = M_B + M_{ST}$$

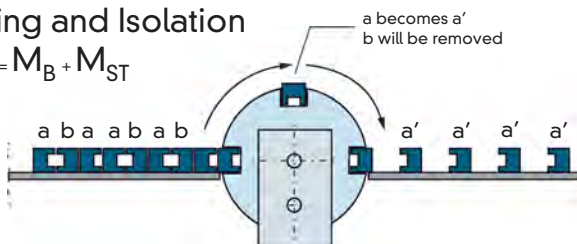

Application examples

Direct driven belt/chain

$$M_{AB} = M_B + M_B$$

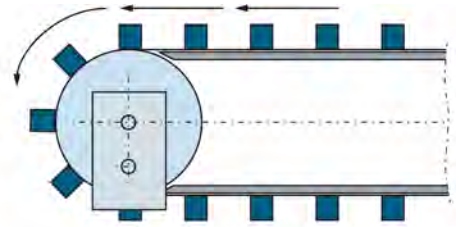

Indirect driven belt/chain

$$M_{AB} = \frac{M_B}{i^2} + \frac{M_R}{i}$$

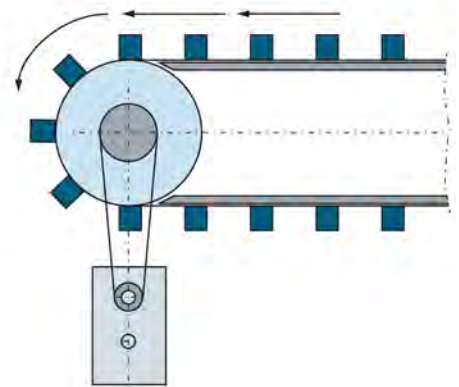

Arm

$$M_{AB} = M_B + M_{ST}$$

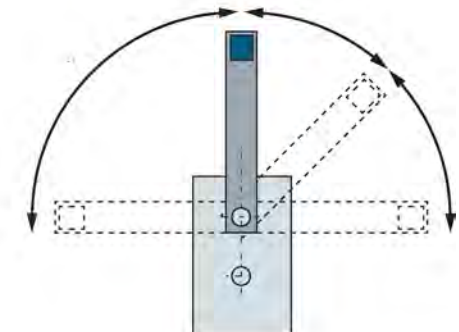

Transducer of rotations in horizontal movement

$$M_{AB} = M_B + M_R$$

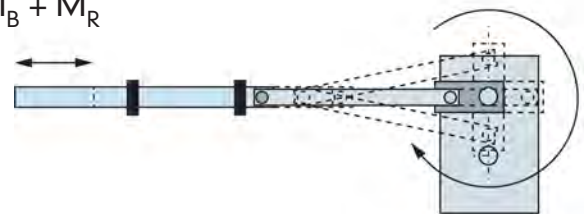

Rotate part

$$M_{AB} = M_B$$



Configuration of all parallel drives

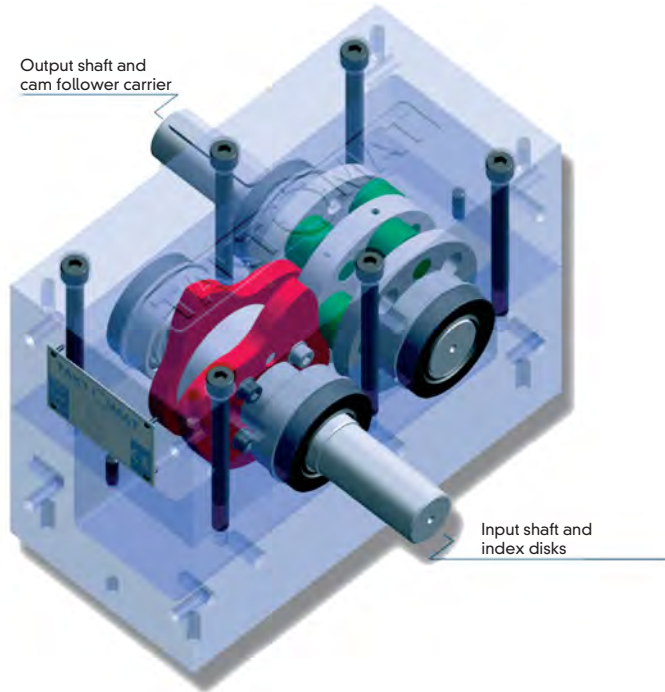

XP030

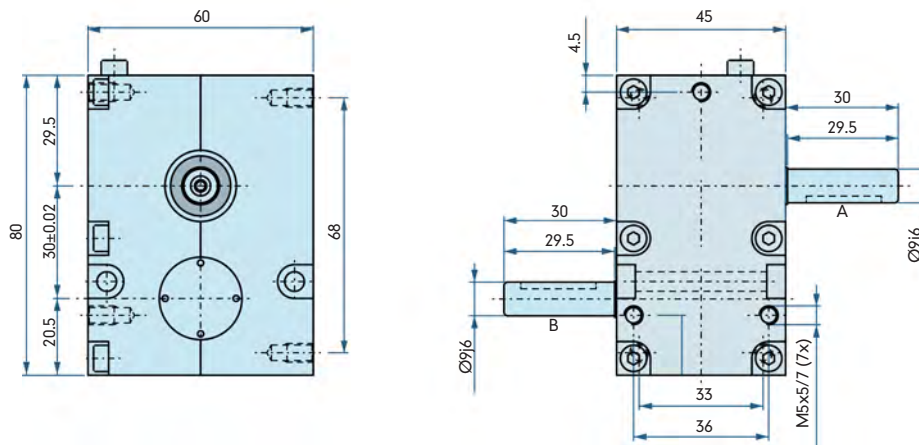

Dimensions

The measurements shown here illustrate the standard unit. We will gladly customize the housing and or shaft(s) to suit your needs. The drive shaft as well as the output shaft are available as double sided shafts with and without a keyway. If you would like to add additional holes into the housing yourself, please contact us for possible drilling depths.

A = Drive shaft

B = Output shaft



The dimensions for the gearmotor may change based on the gearmotor size and options required for the application.

XP030 Load Table

Angle on Output Shaft [°]	Number of Stops n	Index Angle [°]	Acceleration Form MS	Indexer Torque M_{AB} [Nm]			Moment of Inertia J [kgm ²]			Mechanical Index Time t_s [S]		
				n=50	n=100	n=200	n=50	n=100	n=200	n=50	n=100	n=200
360°	1	330	MS30	13	10	9	0.25	0.05	0.01	1.1	0.55	0.28
		300	MS50	13	10	9	0.26	0.05	0.01	1	0.5	0.25
180°	2	270	MS0	13	11	9	0.42	0.09	0.02	0.9	0.45	0.23
		210	MS30	13	10	8	0.29	0.06	0.01	0.7	0.35	0.18
		150	MS50	13	10	8	0.1	0.02	0	0.5	0.25	0.13
120°	3	270	MS0	17	14	12	0.95	0.2	0.04	0.9	0.45	0.23
		210	MS30	17	14	12	0.5	0.1	0.02	0.7	0.32	0.18
		150	MS30	16	13	11	0.24	0.05	0.01	0.5	0.25	0.13
		120	MS30	16	13	11	0.15	0.03	0.01	0.4	0.2	0.1
90°	4	270	MS0	13	13	11	0.97	0.24	0.05	0.9	0.45	0.23
		210	MS0	13	13	11	0.59	0.15	0.03	0.7	0.35	0.18
		150	MS30	12	12	10	0.24	0.06	0.01	0.5	0.25	0.13
		90	MS30	11	11	9	0.08	0.02	0	0.3	0.15	0.08
72°	5	270	MS0	13	13	11	1.21	0.3	0.06	0.9	0.45	0.23
		210	MS0	13	13	11	0.73	0.18	0.04	0.7	0.35	0.18
		150	MS30	12	12	10	0.3	0.07	0.02	0.5	0.25	0.13
		90	MS30	11	11	9	0.1	0.02	0.01	0.3	0.15	0.08
60°	6 ¹⁾	270	MS0	16	16	12	1.79	0.45	0.08	0.9	0.45	0.23
		240	MS0	16	16	12	1.42	0.35	0.07	0.8	0.4	0.2
		180	MS30	15	15	11	0.64	0.16	0.03	0.6	0.3	0.15
		120	MS30	13	13	10	0.25	0.06	0.01	0.4	0.2	0.1
45°	8 ¹⁾	270	MS0	12	12	11	1.79	0.45	0.1	0.9	0.45	0.23
		240	MS0	12	12	11	1.42	0.35	0.08	0.8	0.4	0.2
		180	MS30	12	12	11	0.69	0.17	0.04	0.6	0.3	0.15
		120	MS30	11	11	10	0.28	0.07	0.02	0.4	0.2	0.1

¹⁾ Parallel drives with stop numbers 6, 8 and 10 are designed as a double index, i.e. with each full rotation of the drive shaft, two indexes occur in the output.

²⁾ Parallel drives with 12 stops are designed as a four step index, i.e. with each full rotation of the drive shaft, four indexes occur in the output.

³⁾ The additional load occurring with chains and belts due to friction is not taken into consideration here and must be calculated separately.

Main Dimensions

Shaft distance [mm]	30
Weight without drive [kg]	0.7
Index angle [°]	see Load Table
(other index angles upon request)	
Number of stops	1,2,3,4,5,6,8
(other numbers of stops upon request)	
Rotating direction	right, left, oscillating
Mounting position	ANY

Capacities

Max. Output torque	see Load Table
Input Shaft	
Load rating dynamic [kN]	1.38
Load rating static [kN]	0.58
Output Shaft	
Load rating dynamic [kN]	1.38

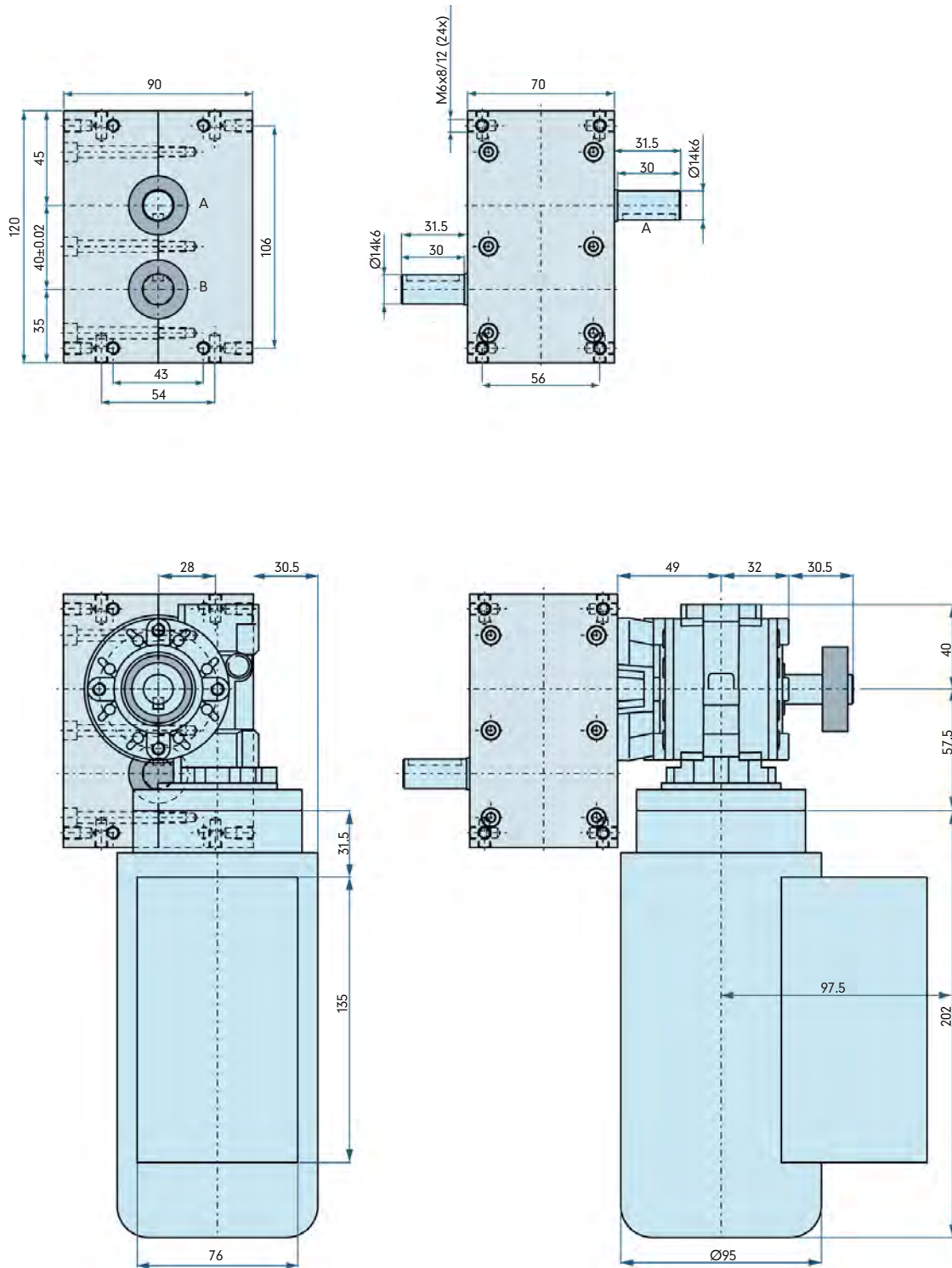

XP040 Dimensions

The measurements shown here illustrate the standard unit. We will gladly customize the housing and or shaft(s) to suit your needs. The drive shaft as well as the output shaft are available as double sided shafts with and without keyways. If you would like to add additional holes into the housing yourself, please contact us for possible drilling depths.

A = Drive Shaft

B = Output Shaft



The dimensions for the gearmotor may change based on the gearmotor size and options required for the application.

XP040 Load Table

Angle on Output Shaft [°]	Number of Stops n	Index Angle [°]	Acceleration Form MS	Indexer Torque M_{AB} [Nm]			Moment of Inertia J [kgm ²]			Mechanical Index Time t_s [S]		
				n=50	n=100	n=200	n=50	n=100	n=200	n=50	n=100	n=200
360°	1	330	MS30	29	25	21	0.56	0.12	0.03	1.1	0.55	0.28
		300	MS50	28	24	20	0.56	0.12	0.02	1	0.5	0.25
180°	2	270	MS0	32	27	24	1.03	0.22	0.05	0.9	0.45	0.23
		210	MS30	26	24	21	0.59	0.14	0.03	0.7	0.35	0.18
		150	MS50	25	23	20	0.2	0.05	0.01	0.5	0.25	0.13
120°	3	270	MS0	39	33	26	2.18	0.46	0.09	0.9	0.45	0.23
		210	MS30	29	33	26	1.14	0.24	0.05	0.7	0.35	0.18
		150	MS30	33	27	23	0.49	0.1	0.02	0.5	0.25	0.13
		120	MS30	30	25	20	0.29	0.06	0.01	0.4	0.2	0.1
90°	4	270	MS0	36	30	24	2.69	0.56	0.11	0.9	0.45	0.23
		210	MS0	36	30	24	1.63	0.34	0.07	0.7	0.35	0.18
		150	MS30	35	29	23	0.7	0.14	0.03	0.5	0.25	0.13
		90	MS30	32	28	21	0.23	0.05	0.01	0.3	0.15	0.08
72°	5	270	MS0	36	30	24	3.36	0.7	0.14	0.9	0.45	0.23
		210	MS0	36	30	24	2.03	0.42	0.08	0.7	0.35	0.18
		150	MS30	35	29	23	0.87	0.18	0.04	0.5	0.25	0.13
		90	MS30	32	28	21	0.29	0.06	0.01	0.3	0.15	0.08
60°	6 ¹⁾	270	MS0	42	34	28	4.7	0.95	0.2	0.9	0.45	0.23
		240	MS0	42	34	28	3.72	0.75	0.15	0.8	0.4	0.2
		180	MS30	40	32	25	1.72	0.34	0.07	0.6	0.3	0.15
		120	MS30	36	29	22	0.69	0.14	0.03	0.4	0.2	0.1
45°	8 ¹⁾	270	MS0	42	34	28	6.27	1.27	0.26	0.9	0.45	0.23
		240	MS0	42	34	28	4.95	1	0.21	0.8	0.4	0.2
		180	MS30	40	32	25	2.29	0.46	0.09	0.6	0.3	0.15
		120	MS30	36	29	22	0.92	0.18	0.03	0.4	0.2	0.1
36°	10 ¹⁾	270	MS0	42	34	28	7.84	1.59	0.33	0.9	0.45	0.23
		240	MS0	42	34	28	6.19	1.25	0.26	0.8	0.4	0.2
		180	MS30	40	32	25	2.86	0.57	0.11	0.6	0.3	0.15
		120	MS30	36	29	22	1.14	0.23	0.04	0.4	0.2	0.1

¹⁾ Parallel drives with stop numbers 6, 8 and 10 are designed as a double index, i.e. with each full rotation of the drive shaft, two indexes occur in the output.

²⁾ Parallel drives with 12 stops are designed as a four step index, i.e. with each full rotation of the drive shaft, four indexes occur in the output.

³⁾ The additional load occurring with chains and belts due to friction is not taken into consideration here and must be calculated separately.

Main Dimensions

Shaft distance [mm]	40
Weight without drive [kg]	2
Index angle [°]	see Load Table
(other index angles upon request)	
Number of stops	1,2,3,4,5,6,8,10
(other numbers of stops upon request)	
Rotating direction	right, left, oscillating
Mounting position	ANY

Capacities

Max. Output torque	See Load Table
Input Shaft	
Load rating dynamic [kN]	4.36
Load rating static [kN]	2.24
Output Shaft	
Load rating dynamic [kN]	4.36
Load rating static [kN]	2.24

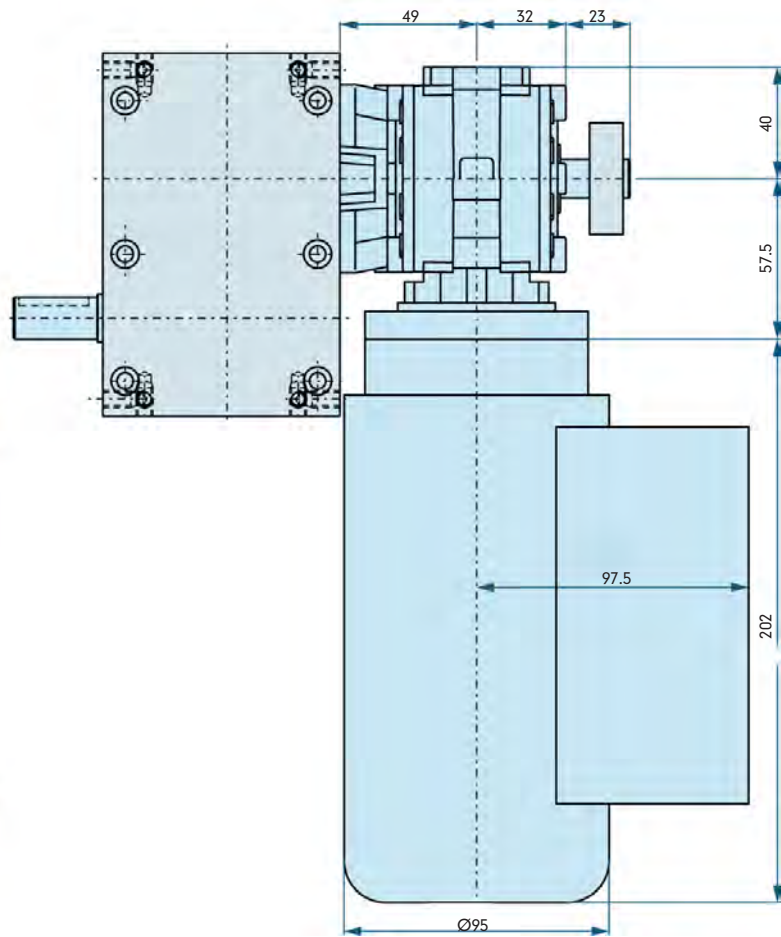
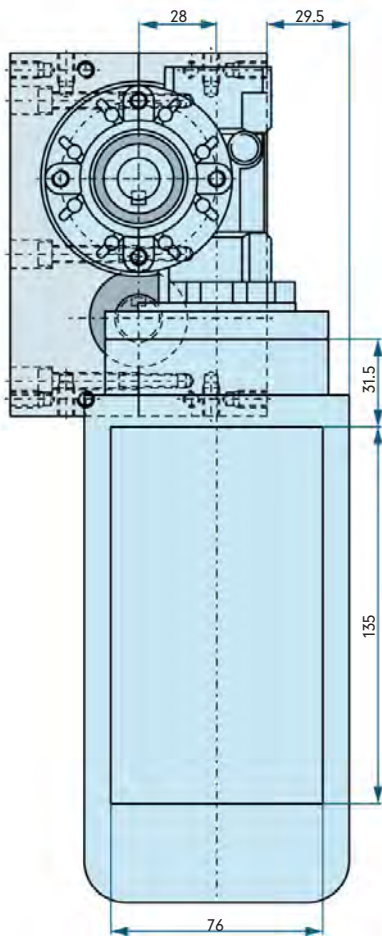
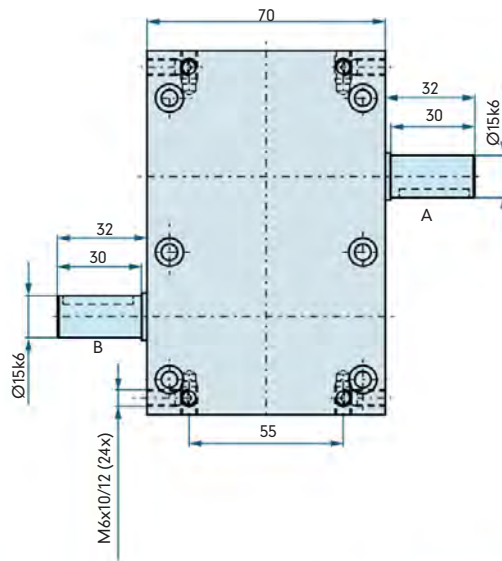
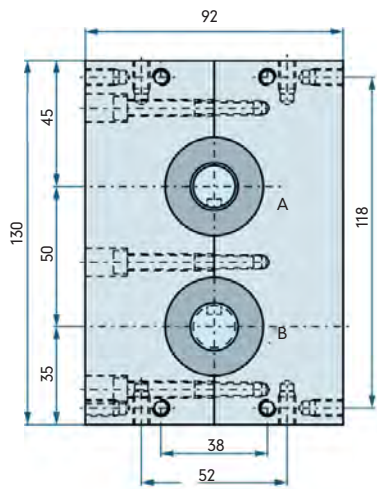

XP050 Dimensions

The measurements shown here illustrate the standard unit. We will gladly customize the housing and or shaft(s) to suit your needs. The drive shaft as well as the output shaft are available as double sided shafts with and without keyways. If you would like to add additional holes into the housing yourself, please contact us for possible drilling depths.

A = Drive Shaft

B = Output Shaft



The dimensions for the gearmotor may change based on the gearmotor size and options required for the application.

XP050 Load Table

Angle on Output Shaft [°]	Number of Stops n	Index Angle [°]	Acceleration Form MS	Indexer Torque M_{AB} [Nm]			Moment of Inertia J [kgm ²]			Mechanical Index Time t_s [S]		
				n=50	n=100	n=200	n=50	n=100	n=200	n=50	n=100	n=200
360°	1	330	MS30	41	34	29	0.79	0.16	0.03	1.1	0.55	0.28
		300	MS50	41	34	29	0.81	0.17	0.04	1	0.5	0.25
180°	2	270	MS0	51	43	37	1.64	0.35	0.07	0.9	0.45	0.23
		210	MS30	49	42	36	1.11	0.24	0.05	0.7	0.35	0.18
		150	MS50	42	37	34	0.33	0.07	0.02	0.5	0.25	0.13
120°	3	270	MS0	54	49	43	3.02	0.69	0.15	0.9	0.45	0.23
		210	MS30	52	47	42	1.52	0.34	0.08	0.7	0.35	0.18
		150	MS30	45	40	33	0.67	0.15	0.03	0.5	0.25	0.13
		120	MS30	43	37	31	0.41	0.09	0.02	0.4	0.2	0.1
90°	4	270	MS0	47	43	38	3.51	0.8	0.18	0.9	0.45	0.23
		210	MS0	45	41	35	2.54	0.58	0.12	0.7	0.35	0.18
		150	MS30	41	37	31	1.02	0.23	0.05	0.5	0.25	0.13
		90	MS30	37	31	26	0.26	0.06	0.01	0.3	0.15	0.08
72°	5	270	MS0	47	43	38	4.38	1	0.22	0.9	0.45	0.23
		210	MS0	45	41	35	2.54	0.58	0.12	0.7	0.35	0.18
		150	MS30	41	37	31	1.02	0.23	0.05	0.5	0.25	0.13
		90	MS30	37	31	26	0.33	0.07	0.01	0.3	0.15	0.08
60°	6 ¹	270	MS0	59	57	53	6.61	1.6	0.37	0.9	0.45	0.23
		240	MS0	58	54	50	5.13	1.19	0.28	0.8	0.4	0.2
		180	MS30	50	46	41	2.15	0.49	0.11	0.6	0.3	0.15
		120	MS30	47	41	38	0.9	0.2	0.05	0.4	0.2	0.1
45°	8 ¹	270	MS0	59	57	53	8.81	2.13	0.49	0.9	0.45	0.23
		240	MS0	58	54	50	6.84	1.59	0.37	0.8	0.4	0.2
		180	MS30	50	46	41	2.86	0.66	0.15	0.6	0.3	0.15
		120	MS30	47	41	38	1.2	0.26	0.06	0.4	0.2	0.1
36°	10 ¹	270	MS0	59	57	53	11.01	2.66	0.62	0.9	0.45	0.23
		240	MS0	58	54	50	8.55	1.99	0.46	0.8	0.4	0.2
		180	MS30	50	46	41	3.58	0.82	0.18	0.6	0.3	0.15
		120	MS30	47	41	38	1.49	0.33	0.08	0.4	0.2	0.1
30°	12 ²	240	MS0	41	38	31	7.25	1.68	0.34	0.8	0.4	0.2

¹) Parallel drives with stop numbers 6, 8 and 10 are designed as a double index, i.e. with each full rotation of the drive shaft, two indexes occur in the output.

²) Parallel drives with 12 stops are designed as a four step index, i.e. with each full rotation of the drive shaft, four indexes occur in the output.

³) The additional load occurring with chains and belts due to friction is not taken into consideration here and must be calculated separately.

Main Dimensions

Shaft distance [mm]	50
Weight without drive [kg]	2.5
Index angle [°]	see Load Table
(other index angles upon request)	
Number of stops	1,2,3,4,5,6,8,10,12
(other numbers of stops upon request)	
Rotating direction	right, left, oscillating
Mounting position	ANY

Capacities

Max. Output torque	See Load Table
Input Shaft	
Load rating dynamic [kN]	6.37
Load rating static [kN]	3.25
Output Shaft	
Load rating dynamic [kN]	6.37
Load rating static [kN]	3.25

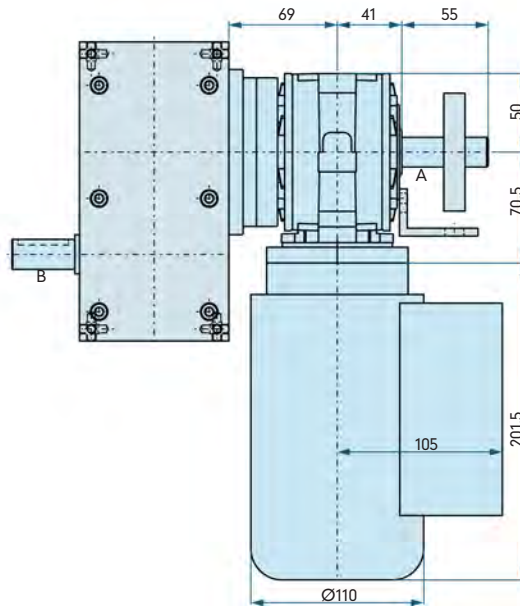
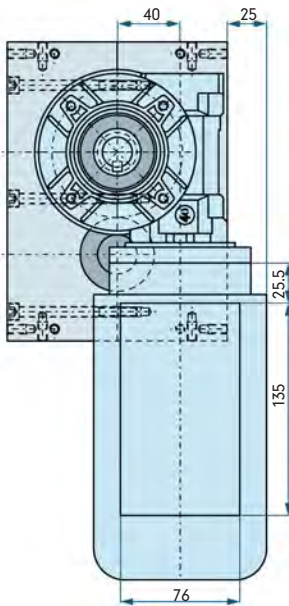
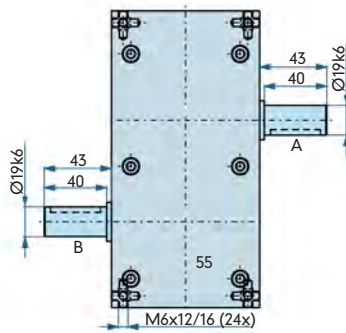
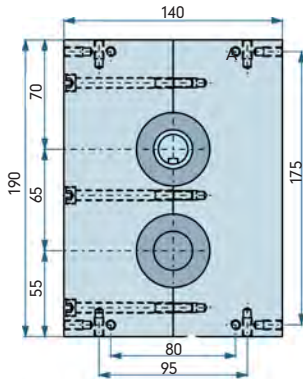

XP065 Dimensions

The measurements shown here illustrate the standard unit. We will gladly customize the housing and or shaft(s) to suit your needs. The drive shaft as well as the output shaft are available as double sided shafts with and without keyways. If you would like to add additional holes into the housing yourself, please contact us for possible drilling depths.

A = Drive Shaft

B = Output Shaft



The dimensions for the gearmotor may change based on the gearmotor size and options required for the application.

XP065 Load Table

Angle on Output Shaft [°]	Number of Stops n	Index Angle [°]	Acceleration Form MS	Indexer Torque M_{AB} [Nm]			Moment of Inertia J [kgm ²]			Mechanical Index Time t_s [S]		
				n=50	n=100	n=200	n=50	n=100	n=200	n=50	n=100	n=200
360°	1	330	MS30	52	43	36	1	0.2	0.04	1.1	0.55	0.28
		300	MS50	48	39	30	1	0.2	0.04	1	0.5	0.25
180°	2	270	MS0	58	51	43	1.9	0.4	0.09	0.9	0.45	0.23
		210	MS30	48	46	41	1.1	0.3	0.06	0.7	0.35	0.18
		150	MS50	42	40	39	0.3	0.1	0.02	0.5	0.25	0.13
120°	3	270	MS0	74	68	59	4.1	1	0.21	0.9	0.45	0.23
		210	MS30	73	67	57	2.1	0.5	0.1	0.7	0.35	0.18
		150	MS30	61	53	46	0.9	0.2	0.04	0.5	0.25	0.13
		120	MS30	60	52	43	0.6	0.1	0.03	0.4	0.2	0.1
90°	4	270	MS0	68	61	53	5.1	1.1	0.25	0.9	0.45	0.23
		210	MS0	66	59	51	3	0.7	0.14	0.7	0.35	0.18
		150	MS30	64	57	49	1.3	0.3	0.06	0.5	0.25	0.13
		90	MS30	64	57	49	0.5	0.1	0.02	0.3	0.15	0.08
72°	5	270	MS0	68	61	53	6.3	1.4	0.31	0.9	0.45	0.23
		210	MS0	66	59	51	3.7	0.8	0.18	0.7	0.35	0.18
		150	MS30	64	57	49	1.6	0.4	0.08	0.5	0.25	0.13
		90	MS30	64	57	49	0.6	0.1	0.03	0.3	0.15	0.08
60°	6 ¹	270	MS0	86	71	56	9.6	2	0.39	0.9	0.45	0.23
		240	MS0	83	69	54	7.3	1.5	0.3	0.8	0.4	0.2
		180	MS30	79	65	51	3.4	0.7	0.14	0.6	0.3	0.15
		120	MS30	75	61	46	1.4	0.3	0.05	0.4	0.2	0.1
45°	8 ¹	270	MS0	86	71	56	12.8	2.6	0.52	0.9	0.45	0.23
		240	MS0	83	69	54	9.8	2	0.4	0.8	0.4	0.2
		180	MS30	79	65	51	4.5	0.9	0.18	0.6	0.3	0.15
		120	MS30	75	61	46	1.9	0.4	0.07	0.4	0.2	0.1
36°	10 ¹	270	MS0	86	71	56	16	3.3	0.65	0.9	0.45	0.23
		240	MS0	83	69	54	12.2	2.5	0.5	0.8	0.4	0.2
		180	MS30	79	65	51	5.7	1.2	0.23	0.6	0.3	0.15
		120	MS30	75	61	46	2.4	0.5	0.09	0.4	0.2	0.1
30°	12 ²	240	MS0	62	51	39	11	2.3	0.43	0.8	0.4	0.2

¹) Parallel drives with stop numbers 6, 8 and 10 are designed as a double index, i.e. with each full rotation of the drive shaft, two indexes occur in the output.

²) Parallel drives with 12 stops are designed as a four step index, i.e. with each full rotation of the drive shaft, four indexes occur in the output.

³) The additional load occurring with chains and belts due to friction is not taken into consideration here and must be calculated separately.

Main Dimensions

Shaft distance [mm] 63
 Weight without drive [kg] 8
 Index angle [°] see Load Table
 (other index angles upon request)
 Number of stops 1,2,3,4,5,6,8,10,12
 (other numbers of stops upon request)
 Rotating Direction right, left, oscillating
 Mounting position ANY

Capacities

Max. Output torque See Load Table
 Input Shaft
 Load rating dynamic [kN] 11.9
 Load rating static [kN] 6.55
 Output Shaft
 Load rating dynamic [kN] 8.06
 Load rating static [kN] 4.75

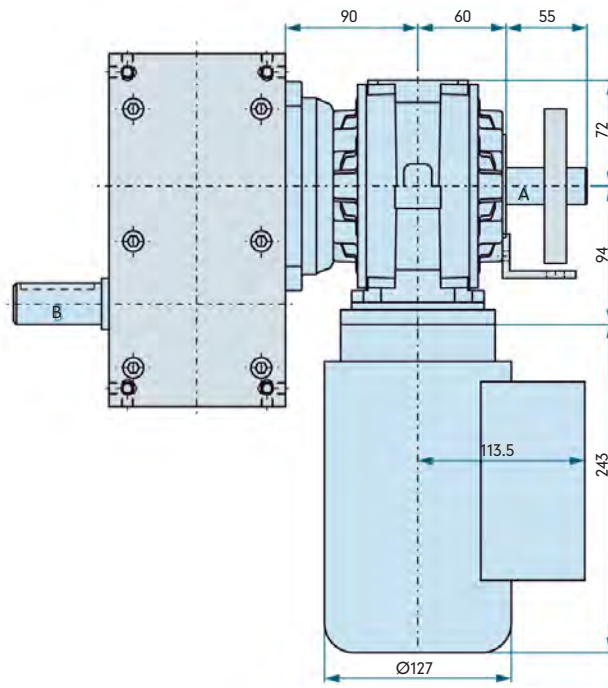
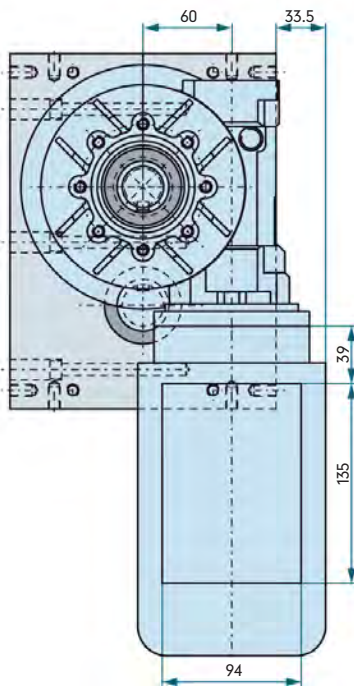
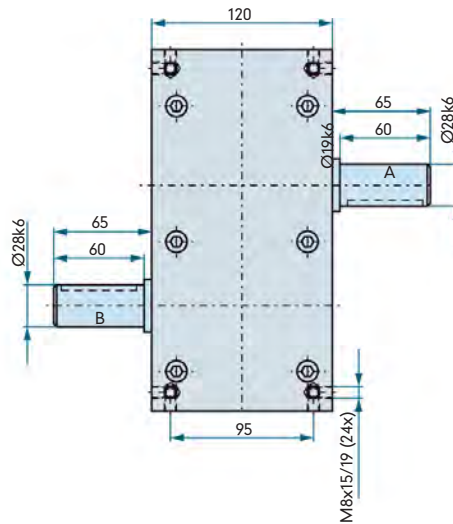
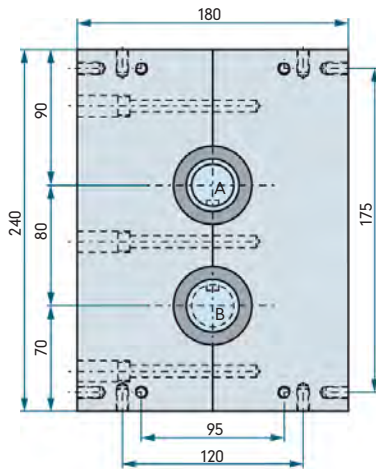

XP080 Dimensions

The measurements shown here illustrate the standard unit. We will gladly customize the housing and or shaft(s) to suit your needs. The drive shaft as well as the output shaft are available as double sided shafts with and without keyways. If you would like to add additional holes into the housing yourself, please contact us for possible drilling depths.

A = Drive Shaft

B = Output Shaft



The dimensions for the gearmotor may change based on the gearmotor size and options required for the application.

XP080 Load Table

Angle on Output Shaft [°]	Number of Stops n	Index Angle [°]	Acceleration Form MS	Indexer Torque M_{AB} [Nm]			Moment of Inertia J [kgm ²]			Mechanical Index Time t_s [S]		
				n=50	n=100	n=200	n=50	n=100	n=200	n=50	n=100	n=200
360°	1	330	MS30	124	102	81	2.4	0.5	0.1	1.1	0.55	0.28
		300	MS50	123	101	79	2.4	0.5	0.1	1	0.5	0.25
180°	2	270	MS0	132	107	93	4.2	0.9	0.19	0.9	0.45	0.23
		210	MS30	131	107	93	3	0.6	0.13	0.7	0.35	0.18
		150	MS50	103	96	89	0.8	0.2	0.04	0.5	0.25	0.13
120°	3	270	MS0	159	137	112	8.9	1.9	0.39	0.9	0.45	0.23
		210	MS30	152	129	101	4.4	0.9	0.18	0.7	0.35	0.18
		150	MS30	127	103	83	1.9	0.4	0.08	0.5	0.25	0.13
		120	MS30	119	97	78	1.1	0.2	0.05	0.4	0.2	0.1
90°	4	270	MS0	157	132	109	11.7	2.5	0.51	0.9	0.45	0.23
		210	MS0	151	126	96	6.8	1.4	0.27	0.7	0.35	0.18
		150	MS30	138	112	88	2.7	0.6	0.11	0.5	0.25	0.13
		90	MS30	118	92	76	0.8	0.2	0.03	0.3	0.15	0.08
72°	5	270	MS0	157	132	109	14.6	3.1	0.64	0.9	0.45	0.23
		210	MS0	151	126	96	8.5	1.8	0.34	0.7	0.35	0.18
		150	MS30	138	112	88	3.4	0.7	0.14	0.5	0.25	0.13
		90	MS30	118	92	76	1.1	0.2	0.04	0.3	0.15	0.08
60°	6 ¹	270	MS0	186	149	124	20.8	4.2	0.87	0.9	0.45	0.23
		240	MS0	174	146	120	15.4	3.2	0.66	0.8	0.4	0.2
		180	MS30	160	122	96	6.9	1.3	0.26	0.6	0.3	0.15
		120	MS30	132	105	81	2.5	0.5	0.1	0.4	0.2	0.1
45°	8 ¹	270	MS0	186	149	124	27.8	5.6	1.16	0.9	0.45	0.23
		240	MS0	174	146	120	20.5	4.3	0.88	0.8	0.4	0.2
		180	MS30	160	122	96	9.2	1.7	0.34	0.6	0.3	0.15
		120	MS30	132	105	81	3.4	0.7	0.13	0.4	0.2	0.1
36°	10 ¹	270	MS0	186	149	124	34.7	7	1.45	0.9	0.45	0.23
		240	MS0	174	146	120	25.7	5.4	1.11	0.8	0.4	0.2
		180	MS30	160	122	96	11.4	2.2	0.43	0.6	0.3	0.15
		120	MS30	132	105	81	4.2	0.8	0.16	0.4	0.2	0.1
30°	12 ²	240	MS0	110	95	76	19.5	4.2	0.84	0.8	0.4	0.2

¹) Parallel drives with stop numbers 6, 8 and 10 are designed as a double index, i.e. with each full rotation of the drive shaft, two indexes occur in the output.

²) Parallel drives with 12 stops are designed as a four step index, i.e. with each full rotation of the drive shaft, four indexes occur in the output.

³) The additional load occurring with chains and belts due to friction is not taken into consideration here and must be calculated separately.

Main Dimensions

Shaft distance [mm]	80
Weight without drive [kg]	12
Switching angle [°]	see Load Table
(other switching angles upon request)	
Number of stops	1,2,3,4,5,6,8,10,12
(other numbers of stops upon request)	
Rotating direction	right, left, oscillating
Mounting position	ANY

Capacities

Max. Output torque	See Load Table
Input Shaft	
Load rating dynamic [kN]	13.8
Load rating static [kN]	8.3
Output Shaft	
Load rating dynamic [kN]	13.8
Load rating static [kN]	8.3

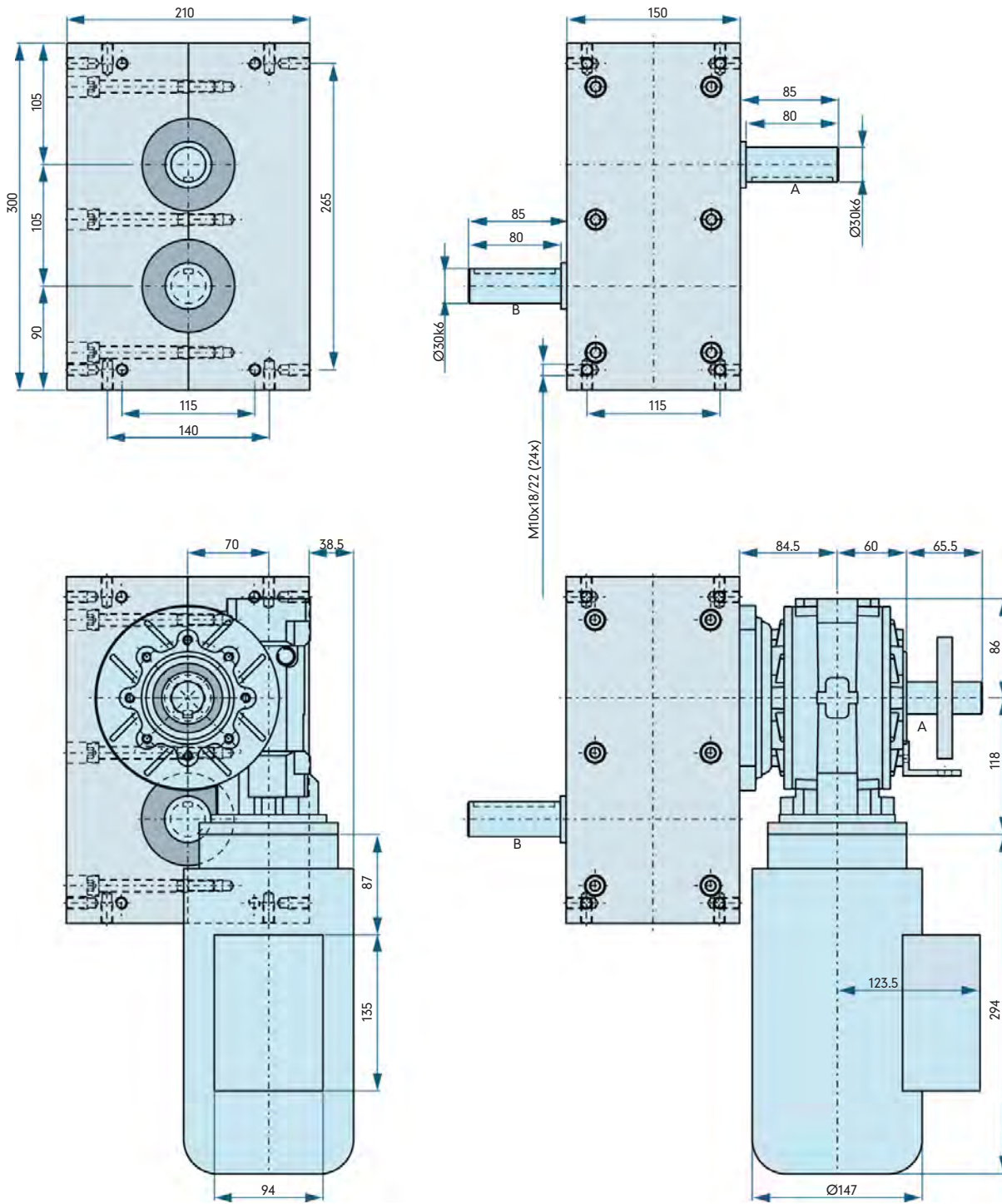

XP105 Dimensions

The measurements shown here illustrate the standard unit. We will gladly customize the housing and or shaft(s) to suit your needs. The drive shaft as well as the output shaft are available as double sided shafts with and without keyways. If you would like to add additional holes into the housing yourself, please contact us for possible drilling depths.

A = Drive Shaft

B = Output Shaft



The dimensions for the gearmotor may change based on the gearmotor size and options required for the application.

XP105 Load Table

Angle on Output Shaft [°]	Number of Stops n	Index Angle [°]	Acceleration Form MS	Indexer Torque M_{AB} [Nm]			Moment of Inertia J [kgm ²]			Mechanical Index Time t_s [S]		
				n=50	n=100	n=200	n=50	n=100	n=200	n=50	n=100	n=200
360°	1	330	MS30	216	175	138	4.2	0.8	0.2	1.1	0.55	0.28
		300	MS50	208	171	132	4.1	0.8	0.2	1	0.5	0.25
180°	2	270	MS0	297	265	230	9.6	2.1	0.5	0.9	0.45	0.23
		210	MS30	285	251	221	6.4	1.4	0.3	0.7	0.35	0.18
		150	MS50	254	204	155	2	0.4	0.1	0.5	0.25	0.13
120°	3	270	MS0	361	319	278	20.2	4.5	1	0.9	0.45	0.23
		210	MS30	350	312	270	10.2	2.3	0.5	0.7	0.35	0.18
		150	MS30	344	306	261	5.1	1.1	0.2	0.5	0.25	0.13
		120	MS30	340	301	256	3.2	0.7	0.2	0.4	0.2	0.1
90°	4	270	MS0	341	298	245	25.5	5.6	1.1	0.9	0.45	0.23
		210	MS0	330	291	238	14.9	3.3	0.7	0.7	0.35	0.18
		150	MS30	318	279	226	6.3	1.4	0.3	0.5	0.25	0.13
		90	MS30	292	269	221	2.1	0.5	0.1	0.3	0.15	0.08
72°	5	270	MS0	341	298	245	31.8	7	1.4	0.9	0.45	0.23
		210	MS0	330	291	238	18.6	4.1	0.8	0.7	0.35	0.18
		150	MS30	318	279	226	7.9	1.7	0.4	0.5	0.25	0.13
		90	MS30	292	269	221	2.6	0.6	0.1	0.3	0.15	0.08
60°	6 ¹	270	MS0	391	351	298	43.8	9.8	2.1	0.9	0.45	0.23
		240	MS0	377	339	286	33.3	7.5	1.6	0.8	0.4	0.2
		180	MS30	305	260	202	13.1	2.8	0.5	0.6	0.3	0.15
		120	MS30	281	239	180	5.4	1.1	0.2	0.4	0.2	0.1
45°	8 ¹	270	MS0	391	351	298	58.4	13.1	2.8	0.9	0.45	0.23
		240	MS0	377	339	286	44.5	1	2.1	0.8	0.4	0.2
		180	MS30	305	260	202	17.5	3.7	0.7	0.6	0.3	0.15
		120	MS30	281	239	180	7.1	1.5	0.3	0.4	0.2	0.1
36°	10 ¹	270	MS0	391	351	298	73	16.4	3.5	0.9	0.45	0.23
		240	MS0	377	339	286	55.6	12.5	2.6	0.8	0.4	0.2
		180	MS30	305	260	202	21.8	4.7	0.9	0.6	0.3	0.15
		120	MS30	281	239	180	8.9	1.9	0.4	0.4	0.2	0.1
30°	12 ²	240	MS0	270	220	170	47.8	9.7	1.9	0.8	0.4	0.2

¹) Parallel drives with stop numbers 6, 8 and 10 are designed as a double index, i.e. with each full rotation of the drive shaft, two indexes occur in the output.

²) Parallel drives with 12 stops are designed as a four step index, i.e. with each full rotation of the drive shaft, four indexes occur in the output.

³) The additional load occurring with chains and belts due to friction is not taken into consideration here and must be calculated separately.

Main Dimensions

Shaft distance [mm] 105
 Weight without drive [kg] 32
 Switching angle [°] see Load Table
 (other switching angles upon request)
 Number of stops 1,2,3,4,5,6,8,10,12
 (other numbers of stops upon request)
 Rotating direction right, left, oscillating
 Mounting position

Capacities

Max. Output torque See Load Table
 Input Shaft
 Load rating dynamic [kN] 30.7
 Load rating static [kN] 19
 Output Shaft
 Load rating dynamic [kN] 30.7
 Load rating static [kN] 19

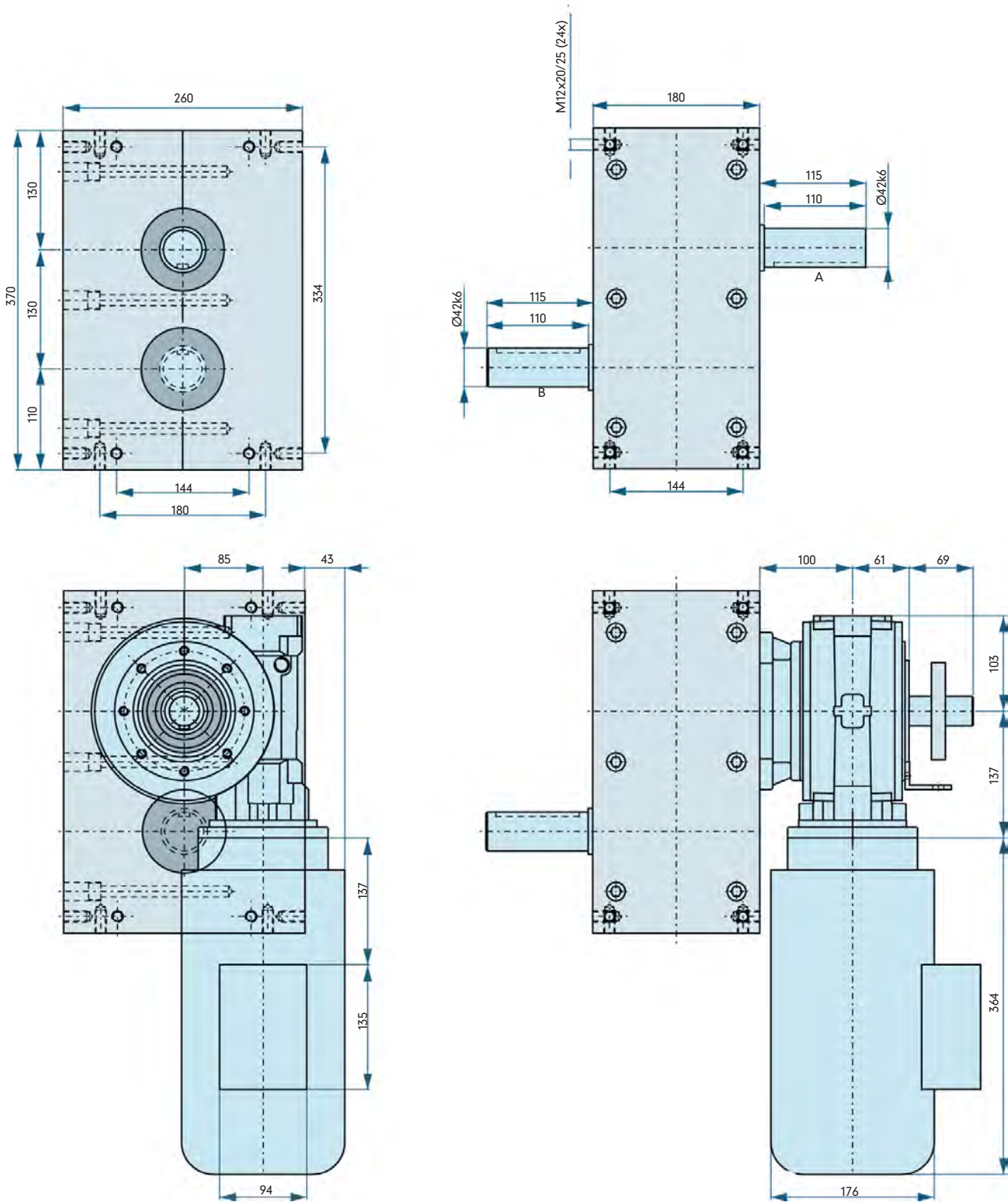

XP130 Dimensions

The measurements shown here illustrate the standard unit. We will gladly customize the housing and or shaft(s) to suit your needs. The drive shaft as well as the output shaft are available as double sided shafts with and without keyways. If you would like to add additional holes into the housing yourself, please contact us for possible drilling depths.

A = Drive Shaft

B = Output Shaft



The dimensions for the gearmotor may change based on the gearmotor size and options required for the application.

XP130 Load Table

Angle on Output Shaft [°]	Number of Stops n	Index Angle [°]	Acceleration Form MS	Indexer Torque M_{AB} [Nm]			Moment of Inertia J [kgm ²]			Mechanical Index Time t_s [S]		
				n=50	n=100	n=200	n=50	n=100	n=200	n=50	n=100	n=200
360°	1	330	MS30	359	290	227	6.9	1.4	0.3	1.1	0.55	0.28
		300	MS50	350	278	210	7	1.4	0.3	1	0.5	0.25
180°	2	270	MS0	449	370	302	14.5	3	0.6	0.9	0.45	0.23
		210	MS30	372	283	213	8.4	1.6	0.3	0.7	0.35	0.18
		150	MS50	310	228	165	2.5	0.5	0.1	0.5	0.25	0.13
120°	3	270	MS0	554	460	375	31	6.4	1.3	0.9	0.45	0.23
		210	MS30	520	436	360	15.2	3.2	0.7	0.7	0.35	0.18
		150	MS30	415	330	240	6.2	1.2	0.2	0.5	0.25	0.13
		120	MS30	390	285	210	3.7	0.7	0.1	0.4	0.2	0.1
90°	4	270	MS0	540	455	360	40.3	8.5	1.7	0.9	0.45	0.23
		210	MS0	501	413	325	22.6	4.7	0.9	0.7	0.35	0.18
		150	MS30	480	390	294	9.5	1.9	0.4	0.5	0.25	0.13
		90	MS30	440	346	263	3.1	0.6	0.1	0.3	0.15	0.08
72°	5	270	MS0	540	455	360	50.4	10.6	2.1	0.9	0.45	0.23
		210	MS0	501	413	325	28.3	5.8	1.1	0.7	0.35	0.18
		150	MS30	480	390	294	11.9	2.4	0.5	0.5	0.25	0.13
		90	MS30	440	346	263	3.9	0.8	0.1	0.3	0.15	0.08
60°	6 ¹	270	MS0	615	537	442	68.9	15	3.1	0.9	0.45	0.23
		240	MS0	576	483	390	51	10.7	2.2	0.8	0.4	0.2
		180	MS30	445	368	280	19.1	3.9	0.8	0.6	0.3	0.15
		120	MS30	395	320	239	7.5	1.5	0.3	0.4	0.2	0.1
45°	8 ¹	270	MS0	615	537	442	91.8	20	4.1	0.9	0.45	0.23
		240	MS0	576	483	390	67.9	14.2	2.9	0.8	0.4	0.2
		180	MS30	445	368	280	25.5	5.3	1	0.6	0.3	0.15
		120	MS30	395	320	239	10	2	0.4	0.4	0.2	0.1
36°	10 ¹	270	MS0	615	537	442	114.8	25	5.2	0.9	0.45	0.23
		240	MS0	576	483	390	84.9	17.8	3.6	0.8	0.4	0.2
		180	MS30	445	368	280	31.8	6.6	1.3	0.6	0.3	0.15
		120	MS30	395	320	239	12.6	2.5	0.5	0.4	0.2	0.1
30°	12 ²	240	MS0	360	290	230	63.7	12.8	2.5	0.8	0.4	0.2

¹) Parallel drives with stop numbers 6, 8 and 10 are designed as a double index, i.e. with each full rotation of the drive shaft, two indexes occur in the output.

²) Parallel drives with 12 stops are designed as a four step index, i.e. with each full rotation of the drive shaft, four indexes occur in the output.

³) The additional load occurring with chains and belts due to friction is not taken into consideration here and must be calculated separately.

Main Dimensions

Shaft distance [mm] 130
 Weight without drive [kg] 45
 Switching angle [°] see Load Table
 (other switching angles upon request)
 Number of stops 1,2,3,4,5,6,8,10,12
 (other numbers of stops upon request)
 Rotating direction right, left, oscillating
 Mounting position ANY

Capacities

Max. Output torque See Load Table
 Input Shaft
 Load rating dynamic [kN] 51
 Load rating static [kN] 39
 Output Shaft
 Load rating dynamic [kN] 51
 Load rating static [kN] 39

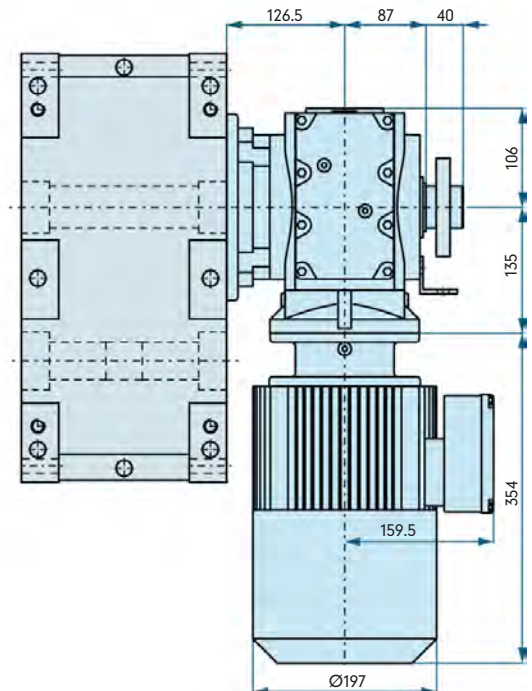
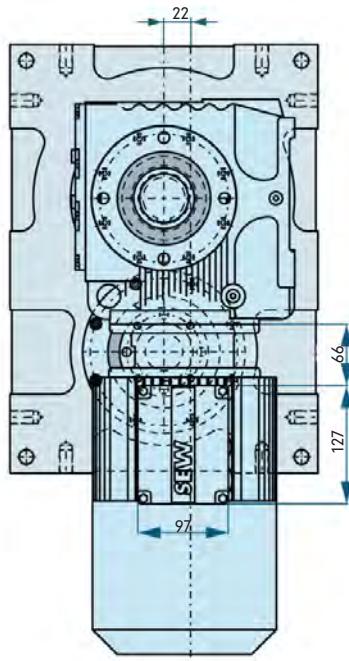
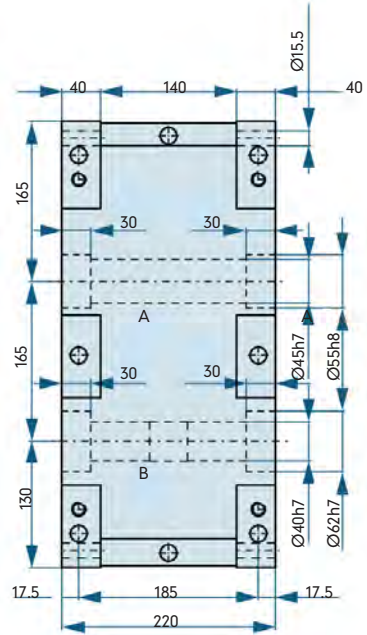
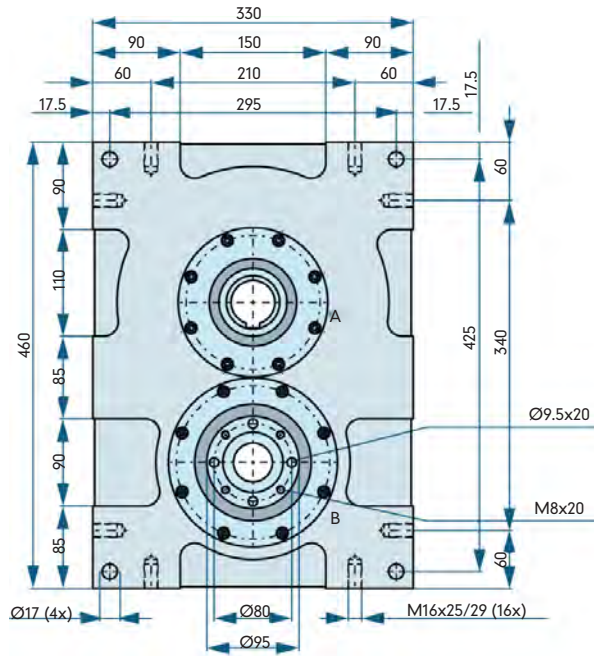

XP165 Dimensions

The measurements shown here illustrate the standard unit. We will gladly customize the housing and or shaft(s) to suit your needs. The drive shaft as well as the output shaft are available as double sided shafts with and without keyways. If you would like to add additional holes into the housing yourself, please contact us for possible drilling depths.

A = Drive Shaft

B = Output Shaft



The dimensions for the gearmotor may change based on the gearmotor size and options required for the application.

XP165 Load Table

Angle on Output Shaft [°]	Number of Stops n	Index Angle [°]	Acceleration Form MS	Indexer Torque M_{AB} [Nm]			Moment of Inertia J [kgm ²]			Mechanical Index Time t_s [S]		
				n=50	n=100	n=200	n=50	n=100	n=200	n=50	n=100	n=200
360°	1	330	MS30	920	760	615	17.7	3.7	0.7	1.1	0.55	0.28
		300	MS50	890	735	580	17.7	3.7	0.7	1	0.5	0.25
180°	2	270	MS0	930	840	680	29.9	6.8	1.4	0.9	0.45	0.23
		210	MS30	805	780	630	18.2	4.4	0.9	0.7	0.35	0.18
		150	MS50	790	740	600	6.3	1.5	0.3	0.5	0.25	0.13
120°	3	270	MS0	950	920	680	53.2	12.9	2.4	0.9	0.45	0.23
		210	MS30	840	810	590	24.5	5.9	1.1	0.7	0.35	0.18
		150	MS30	820	790	570	12.2	2.9	0.5	0.5	0.25	0.13
		120	MS30	805	770	540	7.7	1.8	0.3	0.4	0.2	0.1
90°	4	270	MS0	950	920	680	70.9	17.2	3.2	0.9	0.45	0.23
		210	MS0	840	810	590	37.9	9.1	1.7	0.7	0.35	0.18
		150	MS30	820	790	570	16.3	3.9	0.7	0.5	0.25	0.13
		90	MS30	805	770	540	5.8	1.4	0.2	0.3	0.15	0.08
72°	5	270	MS0	950	920	680	88.6	21.5	4	0.9	0.45	0.23
		210	MS0	840	810	590	47.4	11.4	2.1	0.7	0.35	0.18
		150	MS30	820	790	570	20.4	4.9	0.9	0.5	0.25	0.13
		90	MS30	805	770	540	7.2	1.7	0.3	0.3	0.15	0.08
60°	6 ¹	270	MS0	930	920	890	104.1	25.7	6.2	0.9	0.45	0.23
		240	MS0	910	900	870	80.5	19.9	4.8	0.8	0.4	0.2
		180	MS30	890	880	850	38.2	9.4	2.3	0.6	0.3	0.15
		120	MS30	860	840	820	16.4	4	1	0.4	0.2	0.1
45°	8 ¹	270	MS0	790	770	750	117.9	28.7	7	0.9	0.45	0.23
		240	MS0	770	750	730	90.8	22.1	5.4	0.8	0.4	0.2
		180	MS30	760	740	710	43.5	10.6	1.1	0.6	0.3	0.15
		120	MS30	750	730	720	19.1	4.6	1.1	0.4	0.2	0.1
36°	10 ¹	270	MS0	790	770	750	147.4	35.9	8.7	0.9	0.45	0.23
		240	MS0	770	750	730	113.5	27.6	6.7	0.8	0.4	0.2
		180	MS30	760	750	730	113.5	27.6	6.7	0.6	0.3	0.15
		120	MS30	750	730	720	23.8	5.8	1.4	0.4	0.2	0.1
30°	12 ²	240	MS0	730	720	700	129.1	31.8	7.7	0.8	0.4	0.2

¹) Parallel drives with stop numbers 6, 8 and 10 are designed as a double index, i.e. with each full rotation of the drive shaft, two indexes occur in the output.

²) Parallel drives with 12 stops are designed as a four step index, i.e. with each full rotation of the drive shaft, four indexes occur in the output.

³) The additional load occurring with chains and belts due to friction is not taken into consideration here and must be calculated separately.

Main Dimensions

Shaft distance [mm]	165
Weight without drive [kg]	120
Switching angle [°]	see Load Table
(other switching angles upon request)	
Number of stops	1,2,3,4,5,6,8,10,12
(other numbers of stops upon request)	
Rotating direction	right, left, oscillating
Mounting position	ANY

Capacities

Max. Output torque	See Load Table
Input Shaft	
Load rating dynamic [kN]	116
Load rating static [kN]	153
Output Shaft	
Load rating dynamic [kN]	168
Load rating static [kN]	270

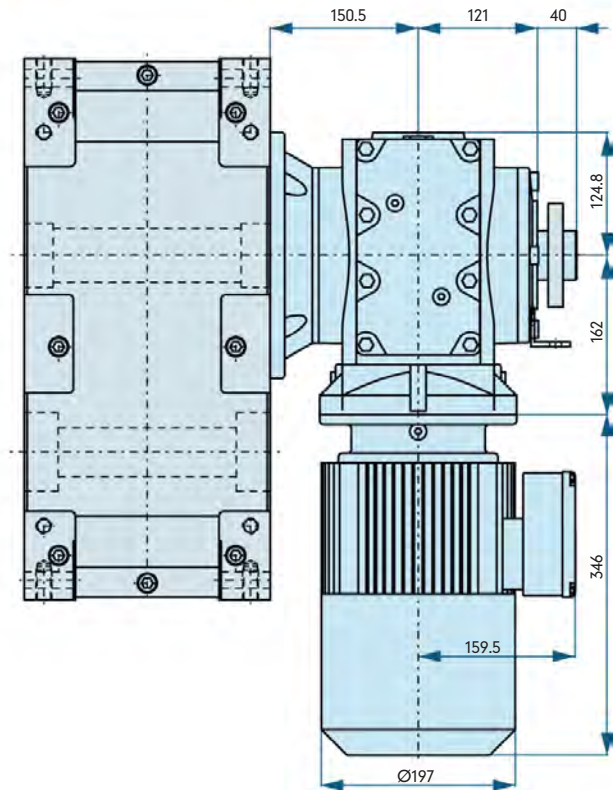
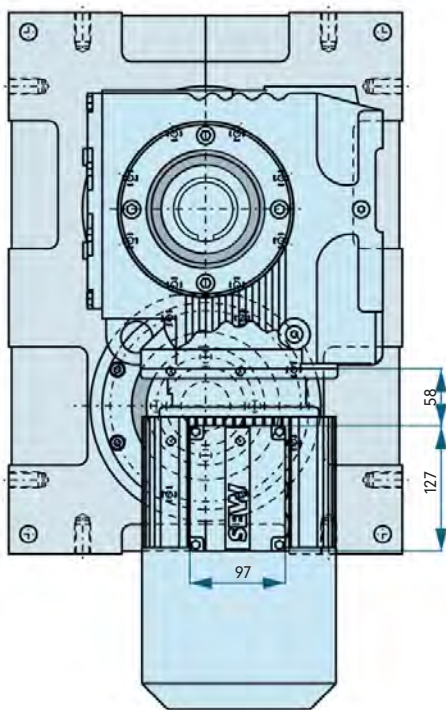
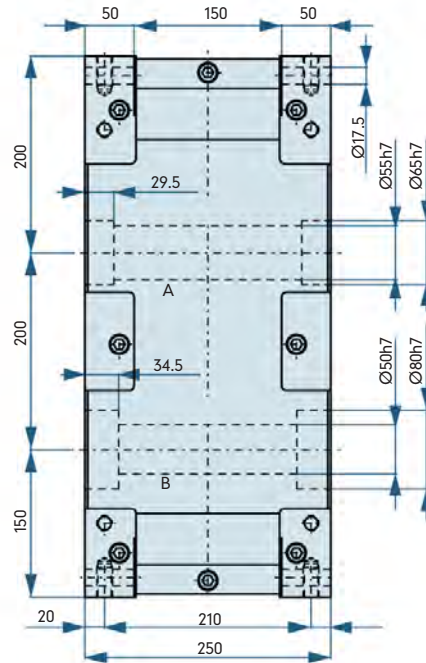
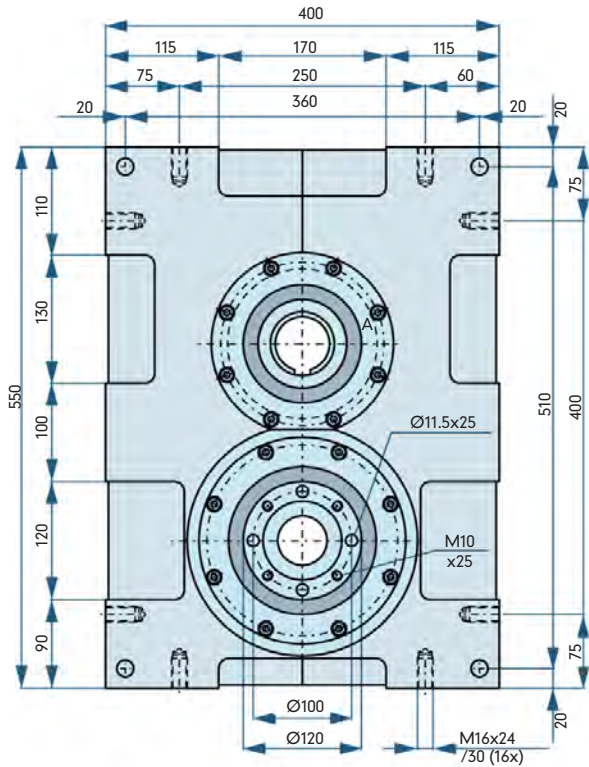

XP200 Dimensions

The measurements shown here illustrate the standard unit. We will gladly customize the housing and or shaft(s) to suit your needs. The drive shaft as well as the output shaft are available as double sided shafts with and without keyways. If you would like to add additional holes into the housing yourself, please contact us for possible drilling depths.



The dimensions for the gearmotor may change based on the gearmotor size and options required for the application.

A = Drive Shaft

B = Output Shaft

XP200 Load Table

Angle on Output Shaft [°]	Number of Stops n	Index Angle [°]	Acceleration Form MS	Indexer Torque M_{AB} [Nm]			Moment of Inertia J [kgm ²]			Mechanical Index Time t_s [S]		
				n=50	n=100	n=200	n=50	n=100	n=200	n=50	n=100	n=200
360°	1	330	MS30	1530	1255	1004	29	6	1.2	1.1	0.55	0.28
		300	MS50	1450	1190	950	29	5.9	1.2	1	0.5	0.25
180°	2	270	MS0	1590	1305	1040	51	10.5	2.1	0.9	0.45	0.23
		210	MS30	1460	1200	960	33	6.8	1.4	0.7	0.35	0.18
		150	MS50	1390	1140	910	11	2.3	0.5	0.5	0.25	0.13
120°	3	270	MS0	1680	1380	1100	94	19.3	3.8	0.9	0.45	0.23
		210	MS30	1590	1305	1045	46	9.5	1.9	0.7	0.35	0.18
		150	MS30	1490	1220	980	22	4.5	0.9	0.5	0.25	0.13
		120	MS30	1480	1215	970	14	2.9	0.6	0.4	0.2	0.1
90°	4	270	MS0	1470	1205	965	110	22.5	4.5	0.9	0.45	0.23
		210	MS0	1440	1181	945	65	13.3	2.7	0.7	0.35	0.18
		150	MS30	1390	1140	910	28	5.7	1.1	0.5	0.25	0.13
		90	MS30	1370	1120	900	10	2	0.4	0.3	0.15	0.08
72°	5	270	MS0	1470	1205	965	137	28.1	5.6	0.9	0.45	0.23
		210	MS0	1440	1180	945	81	16.8	3.3	0.7	0.35	0.18
		150	MS30	1390	1140	910	35	7.1	1.34	0.5	0.25	0.13
		90	MS30	1370	1125	900	12	2.5	0.5	0.3	0.15	0.08
60°	6 ¹	270	MS0	1520	1430	1340	170	40	9.4	0.9	0.45	0.23
		240	MS0	1490	1220	980	132	27	5.4	0.8	0.4	0.2
		180	MS30	1460	1370	1270	63	14.7	3.4	0.6	0.3	0.15
		120	MS30	1420	1335	1240	27	6.4	1.5	0.4	0.2	0.1
45°	8 ¹	270	MS0	1290	1210	1140	193	45.2	10.6	0.9	0.45	0.23
		240	MS0	1270	1195	1120	150	35.2	8.3	0.8	0.4	0.2
		180	MS30	1260	1180	1110	72	16.9	4	0.6	0.3	0.15
		120	MS30	1240	1166	1100	32	7.4	1.7	0.4	0.2	0.1
36°	10 ¹	270	MS0	1290	1210	1140	241	56.4	13.3	0.9	0.45	0.23
		240	MS0	1270	1195	1120	187	44	10.3	0.8	0.4	0.2
		180	MS30	1260	1180	1110	90	21.1	5	0.6	0.3	0.15
		120	MS30	1240	1166	1100	39	9.3	2.2	0.4	0.2	0.1
30°	12 ²	240	MS0	1190	1140	1090	211	50.4	12.1	0.8	0.4	0.2

¹) Parallel drives with stop numbers 6, 8 and 10 are designed as a double index, i.e. with each full rotation of the drive shaft, two indexes occur in the output.

²) Parallel drives with 12 stops are designed as a four step index, i.e. with each full rotation of the drive shaft, four indexes occur in the output.

³) The additional load occurring with chains and belts due to friction is not taken into consideration here and must be calculated separately.

Main Dimensions

Shaft distance [mm]	200
Weight without drive [kg]	220
Switching angle [°]	see Load Table
(other switching angles upon request)	
Number of stops	1,2,3,4,5,6,8,10,12
(other numbers of stops upon request)	
Rotating direction	right, left, oscillating
Mounting position	

Capacities

Max. Output torque	See Load Table
Input Shaft	
Load rating dynamic [kN]	168
Load rating static [kN]	270
Output Shaft	
Load rating dynamic [kN]	242
Load rating static [kN]	415

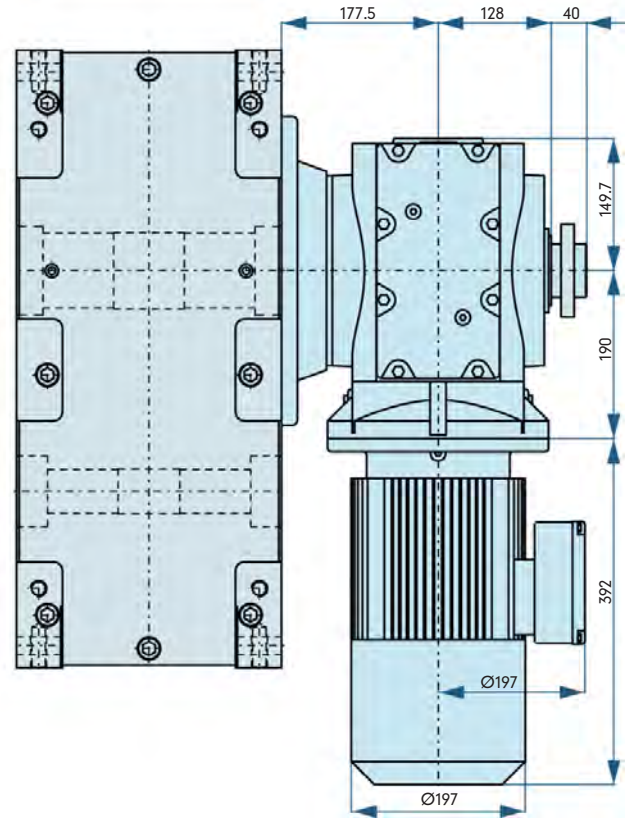
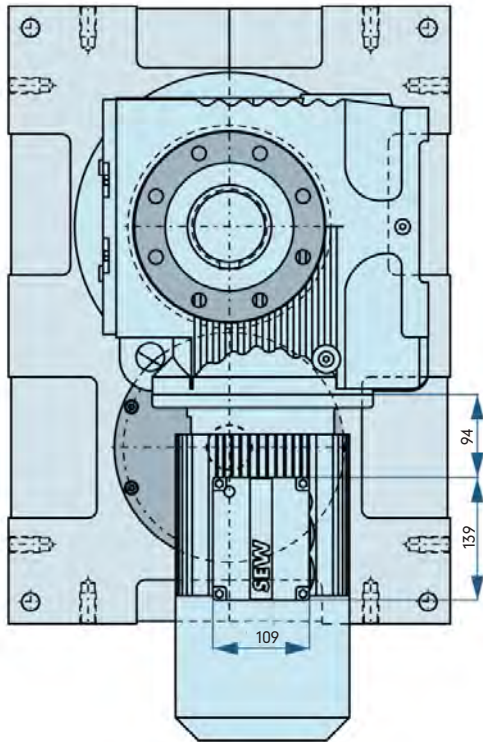
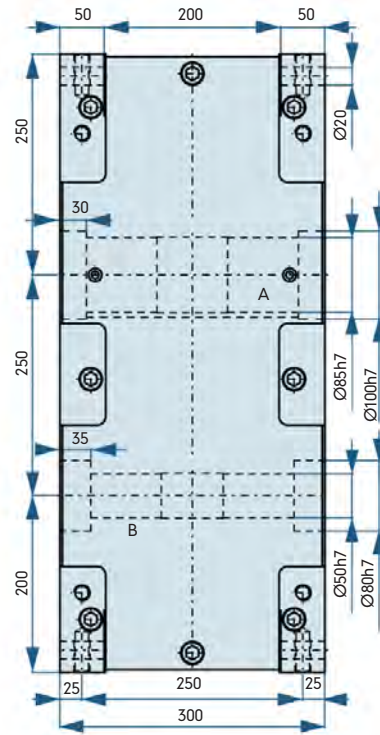
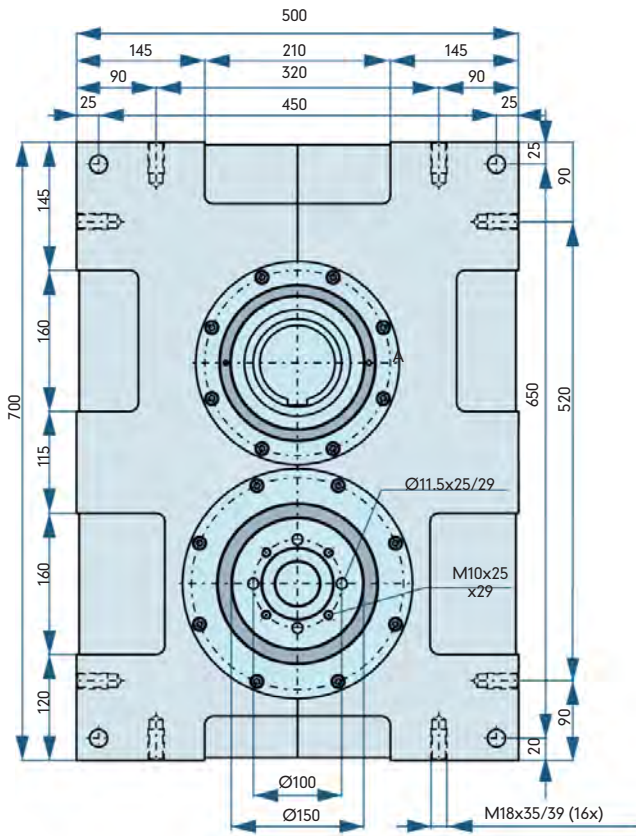

XP250 Dimensions

The measurements shown here illustrate the standard unit. We will gladly customize the housing and or shaft(s) to suit your needs. The drive shaft as well as the output shaft are available as double sided shafts with and without keyways. If you would like to add additional holes into the housing yourself, please contact us for possible drilling depths.

A = Drive Shaft

B = Output Shaft



The dimensions for the gearmotor may change based on the gearmotor size and options required for the application.

XP250 Load Table

Angle on Output Shaft [°]	Number of Stops n	Index Angle [°]	Acceleration Form MS	Indexer Torque M_{AB} [Nm]			Moment of Inertia J [kgm ²]			Mechanical Index Time t_s [S]		
				n=50	n=100	n=200	n=50	n=100	n=200	n=50	n=100	n=200
360°	1	330	MS30	2750	2255	1827	53	10.9	2.2	1.1	0.55	0.28
		300	MS50	2680	2020	1635	53	10	2	1	0.5	0.25
180°	2	270	MS0	2710	2300	1860	90	18.5	3.7	0.9	0.45	0.23
		210	MS30	2480	2035	1650	56	11.5	2.3	0.7	0.35	0.18
		150	MS50	2430	1990	1610	19	4	0.8	0.5	0.25	0.13
120°	3	270	MS0	2870	2350	1905	161	32.9	6.7	0.9	0.45	0.23
		210	MS30	2690	2200	1780	79	16.1	3.3	0.7	0.35	0.18
		150	MS30	2510	2060	1665	37	7.7	1.6	0.5	0.25	0.13
		120	MS30	2490	2040	1655	24	4.9	1	0.4	0.2	0.1
90°	4	270	MS0	2690	2205	1790	201	41.1	8.3	0.9	0.45	0.23
		210	MS0	2670	2189	1773	121	24.7	5	0.7	0.35	0.18
		150	MS30	2570	2110	1710	52	10.6	2.2	0.5	0.25	0.13
		90	MS30	2570	2110	1710	18	3.8	0.8	0.3	0.15	0.08
72°	5	270	MS0	2690	2205	1790	251	51.4	10.4	0.9	0.45	0.23
		210	MS0	2370	2189	1773	151	30.9	6.3	0.7	0.35	0.18
		150	MS30	2610	2140	1734	65	13.3	2.7	0.5	0.25	0.13
		90	MS30	2570	2110	1710	23	4.7	1	0.3	0.15	0.08
60°	6 ¹	270	MS0	2810	2700	2570	315	75.6	18	0.9	0.45	0.23
		240	MS0	2730	2630	2510	241	58.2	13.9	0.8	0.4	0.2
		180	MS30	2590	2490	2310	111	26.7	6.2	0.6	0.3	0.15
		120	MS30	2540	2410	2260	48	11.5	2.7	0.4	0.2	0.1
45°	8 ¹	270	MS0	2530	2400	2290	378	89.6	21.4	0.9	0.45	0.23
		240	MS0	2470	2370	2210	291	69.9	16.3	0.8	0.4	0.2
		180	MS30	2410	2300	2180	138	32.9	7.8	0.6	0.3	0.15
		120	MS30	2380	2270	2150	61	14.4	3.4	0.4	0.2	0.1
36°	10 ¹	270	MS0	2530	2400	2290	472	112	26.7	0.9	0.45	0.23
		240	MS0	2470	2370	2210	364	87.4	20.4	0.8	0.4	0.2
		180	MS30	2410	2300	2180	172	41.1	9.7	0.6	0.3	0.15
		120	MS30	2380	2270	2150	76	18	4.3	0.4	0.2	0.1
30°	12 ²	240	MS0	2250	2120	1990	398	93.8	22	0.8	0.4	0.2

¹) Parallel drives with stop numbers 6, 8 and 10 are designed as a double index, i.e. with each full rotation of the drive shaft, two indexes occur in the output.

²) Parallel drives with 12 stops are designed as a four step index, i.e. with each full rotation of the drive shaft, four indexes occur in the output.

³) The additional load occurring with chains and belts due to friction is not taken into consideration here and must be calculated separately.

Main Dimensions

Shaft distance [mm]	250
Weight without drive [kg]	350
Switching angle [°]	see Load Table
(other switching angles upon request)	
Number of stops	1,2,3,4,5,6,8,10,12
(other numbers of stops upon request)	
Rotating direction	right, left, oscillating
Mounting position	ANY

Capacities

Max. Output torque	See Load Table
Input Shaft	
Load rating dynamic [kN]	242
Load rating static [kN]	415
Output Shaft	
Load rating dynamic [kN]	365
Load rating static [kN]	655



MOTION INDEX DRIVES

PARALLEL INDEX DRIVES
TP Series

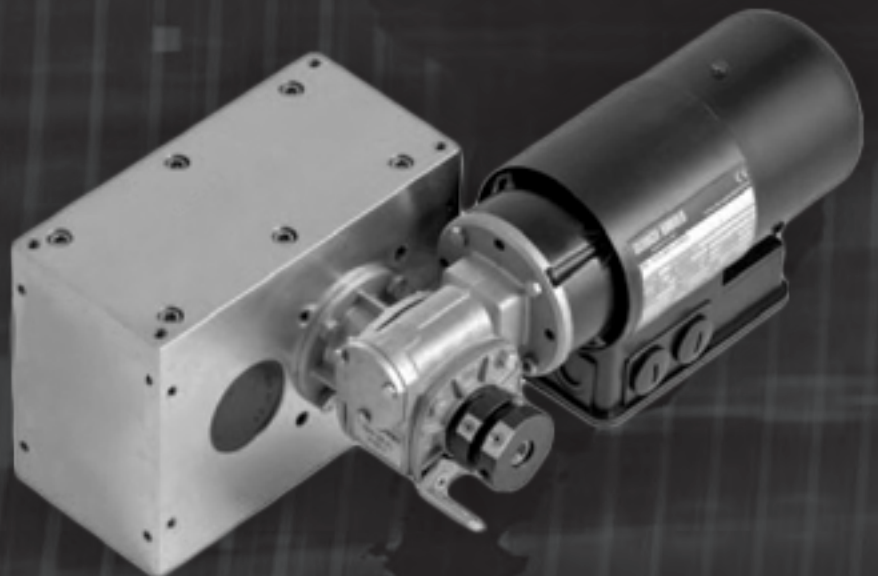

Calculations

J = moment of inertia

$$M_B = c_a \times n \frac{2\pi}{n \times t^2}$$

$$M_R = \mu \times g \times R \times m$$

$$M_{AB} = M_B + M_R + (M_{ST})^*$$

$$M_{ST} = m \times g \times R$$

$$M_{AN} = ((M_B \times c_m) + (M_{ST} \times C_v)) \times \frac{360^\circ}{n \times a}$$

$$P = \frac{M_{AN} \times f_a}{9550 \times n}$$

*with one-sided lifting of loads

J = moment of inertia [kgm²]

M_B = acceleration torque [Nm]

M_R = friction torque [Nm]

M_{AB} = indexer torque [Nm]

M_{ST} = static torque [Nm]

M_{AN} = drive torque [Nm]

μ = friction coefficient

g = acceleration of gravity = 9,81m/s²

R = radius

m = mass [kg]

a = switching angle [°]

t_s = index time [s]

n = number of stops

i = ratio

P = drive power [kW]

n = efficiency worm gear

f_a = drive speed [1/min]

MS = ACCELERATION	MS0	MS30	M250
c _a = acceleration coefficient	5.53	6.41	8.01
c _m = performance coefficient	0.99	0.81	0.72
c _v = speed coefficient	1.76	1.43	1.27

Sorting and Isolation

$$M_{AB} = M_B + M_{ST}$$

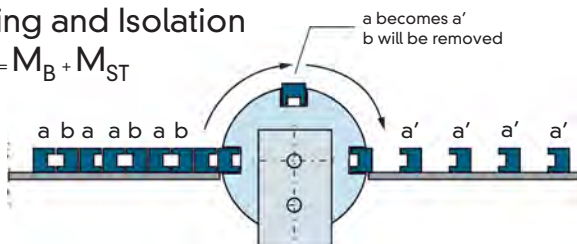

Application examples

Direct driven belt/chain

$$M_{AB} = M_B + M_B$$

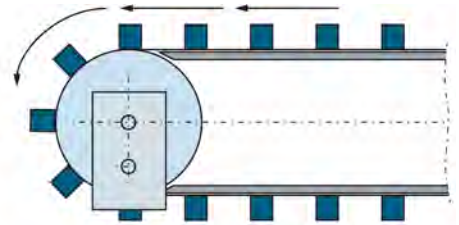

Indirect driven belt/chain

$$M_{AB} = \frac{M_B}{i^2} + \frac{M_R}{i}$$

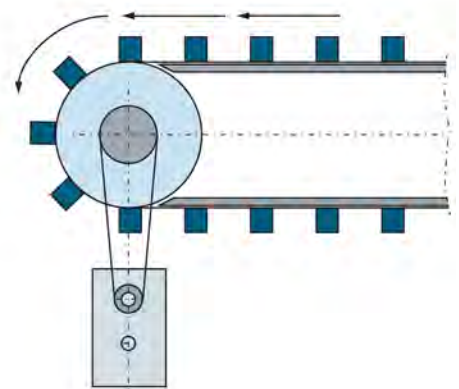

Arm

$$M_{AB} = M_B + M_{ST}$$

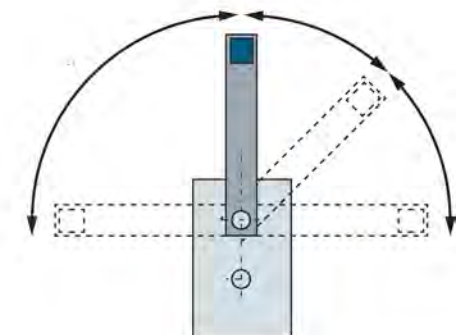

Transducer of rotations in horizontal movement

$$M_{AB} = M_B + M_R$$

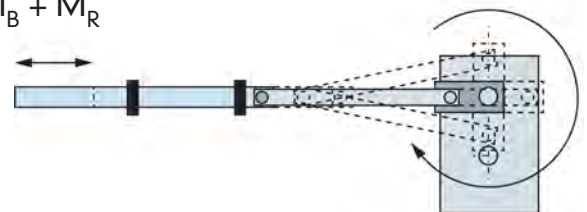

Rotate part

$$M_{AB} = M_B$$

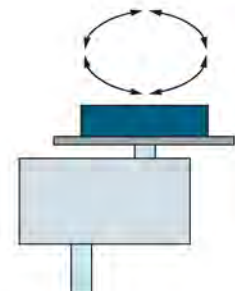

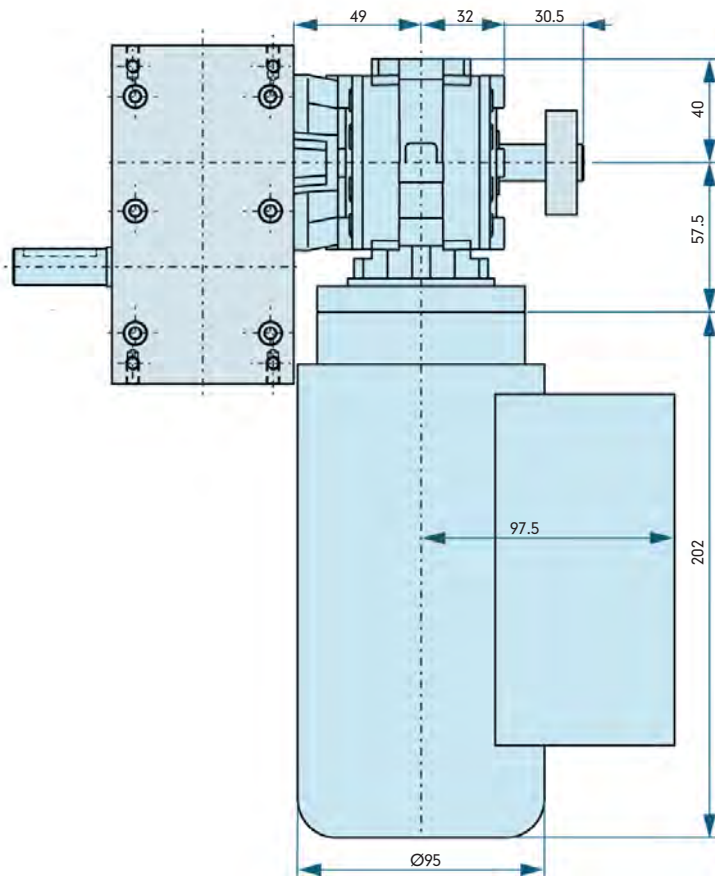
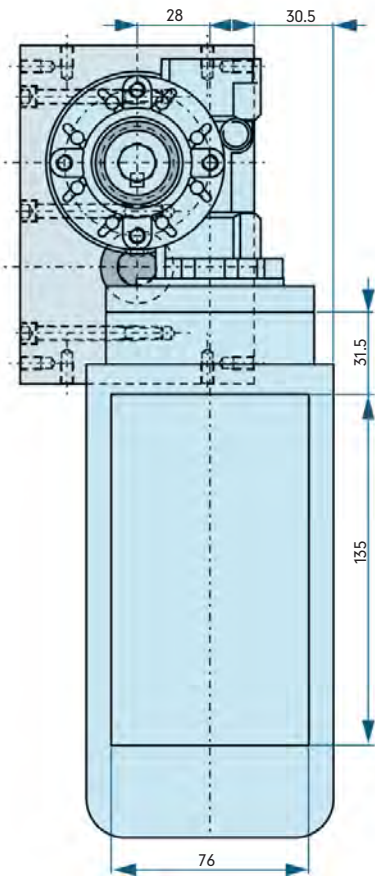
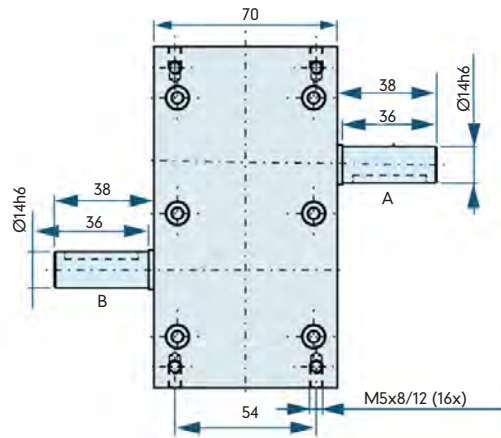
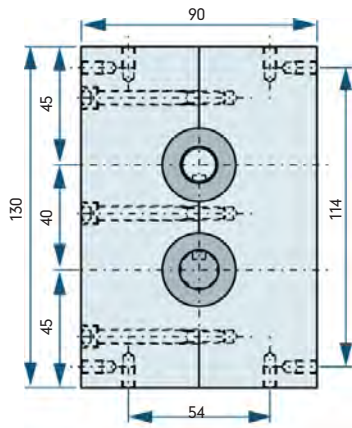

TP040 Dimensions

The measurements shown here illustrate the standard unit. We will gladly customize the housing and or shaft(s) to suit your needs. The drive shaft as well as the output shaft are available as double sided shafts with and without keyways. If you would like to add additional holes into the housing yourself, please contact us for possible drilling depths.

A = Drive Shaft

B = Output Shaft



The dimensions for the gearmotor may change based on the gearmotor size and options required for the application.

TP040 Load Table

Angle on Output Shaft [°]	Number of Stops n	Index Angle [°]	Acceleration Form MS	Indexer Torque M_{AB} [Nm]			Moment of Inertia J [kgm ²]			Mechanical Index Time t_s [S]		
				n=50	n=100	n=200	n=50	n=100	n=200	n=50	n=100	n=200
360°	1	330	MS30	29	25	21	0.56	0.12	0.03	1.1	0.55	0.28
		300	MS50	28	24	20	0.56	0.12	0.02	1	0.5	0.25
180°	2	270	MS0	32	27	24	1.03	0.22	0.05	0.9	0.45	0.23
		210	MS30	26	24	21	0.59	0.14	0.03	0.7	0.35	0.18
		150	MS50	25	23	20	0.2	0.05	0.01	0.5	0.25	0.13
120°	3	270	MS0	39	33	26	2.18	0.46	0.09	0.9	0.45	0.23
		210	MS30	29	33	26	1.14	0.24	0.05	0.7	0.35	0.18
		150	MS30	33	27	23	0.49	0.1	0.02	0.5	0.25	0.13
		120	MS30	30	25	20	0.29	0.06	0.01	0.4	0.2	0.1
90°	4	270	MS0	36	30	24	2.69	0.56	0.11	0.9	0.45	0.23
		210	MS0	36	30	24	1.63	0.34	0.07	0.7	0.35	0.18
		150	MS30	35	29	23	0.7	0.14	0.03	0.5	0.25	0.13
		90	MS30	32	28	21	0.23	0.05	0.01	0.3	0.15	0.08
72°	5	270	MS0	36	30	24	3.36	0.7	0.14	0.9	0.45	0.23
		210	MS0	36	30	24	2.03	0.42	0.08	0.7	0.35	0.18
		150	MS30	35	29	23	0.87	0.18	0.04	0.5	0.25	0.13
		90	MS30	32	28	21	0.29	0.06	0.01	0.3	0.15	0.08
60°	6 ¹⁾	270	MS0	42	34	28	4.7	0.95	0.2	0.9	0.45	0.23
		240	MS0	42	34	28	3.72	0.75	0.15	0.8	0.4	0.2
		180	MS30	40	32	25	1.72	0.34	0.07	0.6	0.3	0.15
		120	MS30	36	29	22	0.69	0.14	0.03	0.4	0.2	0.1
45°	8 ¹⁾	270	MS0	42	34	28	6.27	1.27	0.26	0.9	0.45	0.23
		240	MS0	42	34	28	4.95	1	0.21	0.8	0.4	0.2
		180	MS30	40	32	25	2.29	0.46	0.09	0.6	0.3	0.15
		120	MS30	36	29	22	0.92	0.18	0.03	0.4	0.2	0.1
36°	10 ¹⁾	270	MS0	42	34	28	7.84	1.59	0.33	0.9	0.45	0.23
		240	MS0	42	34	28	6.19	1.25	0.26	0.8	0.4	0.2
		180	MS30	40	32	25	2.86	0.57	0.11	0.6	0.3	0.15
		120	MS30	36	29	22	1.14	0.23	0.04	0.4	0.2	0.1

¹⁾ Parallel drives with stop numbers 6, 8 and 10 are designed as a double index, i.e. with each full rotation of the drive shaft, two indexes occur in the output.

²⁾ Parallel drives with 12 stops are designed as a four step index, i.e. with each full rotation of the drive shaft, four indexes occur in the output.

³⁾ The additional load occurring with chains and belts due to friction is not taken into consideration here and must be calculated separately.

Main Dimensions

Shaft distance [mm]	40
Weight without drive [kg]	2
Switching angle [°]	see Load Table
(other switching angles upon request)	
Number of stops	1,2,3,4,5,6,8,10
(other numbers of stops upon request)	
Rotating direction	right, left, oscillating
Mounting position	ANY

Capacities

Max. Output torque	See Load Table
Input Shaft	
Load rating dynamic [kN]	4.36
Load rating static [kN]	2.24
Output Shaft	
Load rating dynamic [kN]	4.36
Load rating static [kN]	2.24

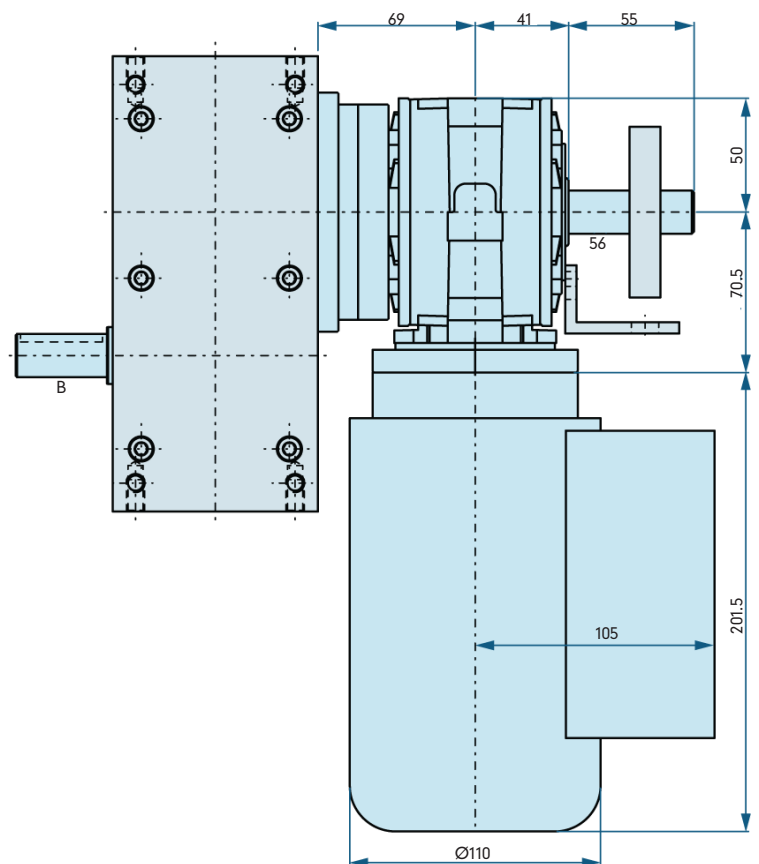
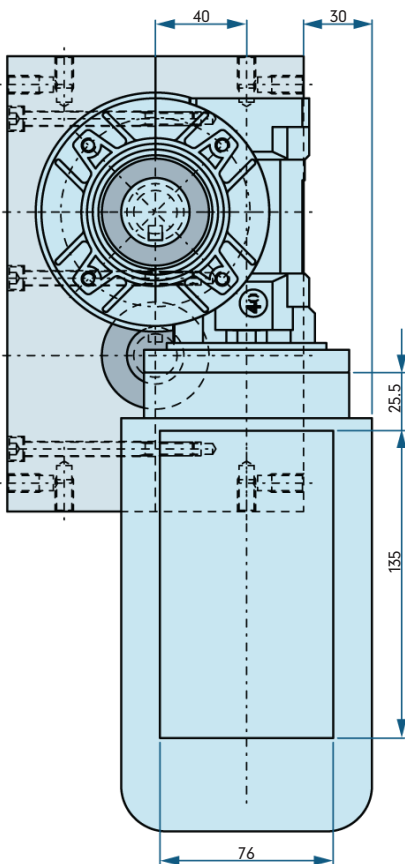
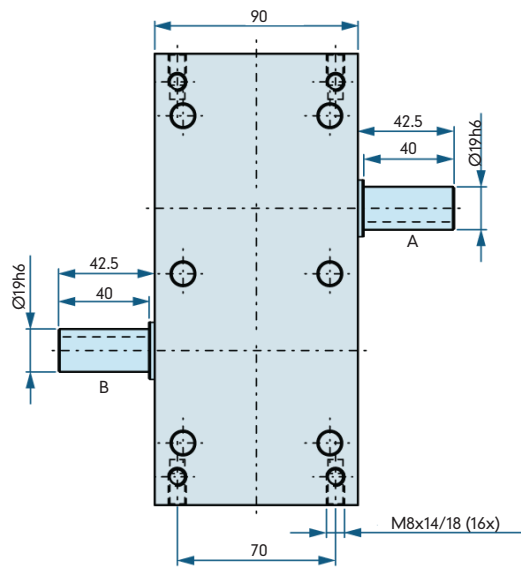
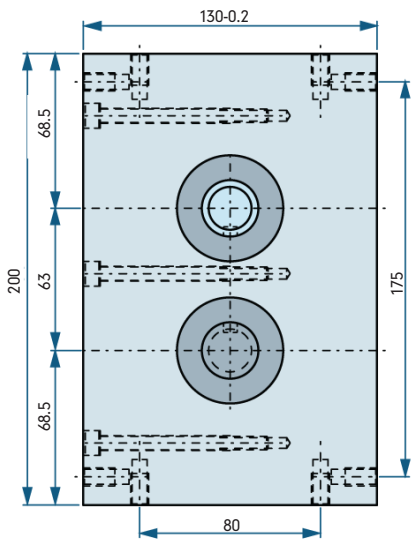

TP063 Dimensions

The measurements shown here illustrate the standard unit. We will gladly customize the housing and or shaft(s) to suit your needs. The drive shaft as well as the output shaft are available as double sided shafts with and without keyways. If you would like to add additional holes into the housing yourself, please contact us for possible drilling depths.

A = Drive Shaft

B = Output Shaft



The dimensions for the gearmotor may change based on the gearmotor size and options required for the application.

TP063 Load Table

Angle on Output Shaft [°]	Number of Stops n	Index Angle [°]	Acceleration Form MS	Indexer Torque M_{AB} [Nm]			Moment of Inertia J [kgm ²]			Mechanical Index Time t_s [S]		
				n=50	n=100	n=200	n=50	n=100	n=200	n=50	n=100	n=200
360°	1	330	MS30	52	43	36	1	0.2	0.04	1.1	0.55	0.28
		300	MS50	48	39	30	1	0.2	0.04	1	0.5	0.25
180°	2	270	MS0	58	51	43	1.9	0.4	0.09	0.9	0.45	0.23
		210	MS30	48	46	41	1.1	0.3	0.06	0.7	0.35	0.18
		150	MS50	42	40	39	0.3	0.1	0.02	0.5	0.25	0.13
120°	3	270	MS0	74	68	59	4.1	1	0.21	0.9	0.45	0.23
		210	MS30	73	67	57	2.1	0.5	0.1	0.7	0.35	0.18
		150	MS30	61	53	46	0.9	0.2	0.04	0.5	0.25	0.13
		120	MS30	60	52	43	0.6	0.1	0.03	0.4	0.2	0.1
90°	4	270	MS0	68	61	53	5.1	1.1	0.25	0.9	0.45	0.23
		210	MS0	66	59	51	3	0.7	0.14	0.7	0.35	0.18
		150	MS30	64	57	49	1.3	0.3	0.06	0.5	0.25	0.13
		90	MS30	64	57	49	0.5	0.1	0.02	0.3	0.15	0.08
72°	5	270	MS0	68	61	53	6.3	1.4	0.31	0.9	0.45	0.23
		210	MS0	66	59	51	3.7	0.8	0.18	0.7	0.35	0.18
		150	MS30	64	57	49	1.6	0.4	0.08	0.5	0.25	0.13
		90	MS30	64	57	49	0.6	0.1	0.03	0.3	0.15	0.08
60°	6 ¹	270	MS0	86	71	56	9.6	2	0.39	0.9	0.45	0.23
		240	MS0	83	69	54	7.3	1.5	0.3	0.8	0.4	0.2
		180	MS30	79	65	51	3.4	0.7	0.14	0.6	0.3	0.15
		120	MS30	75	61	46	1.4	0.3	0.05	0.4	0.2	0.1
45°	8 ¹	270	MS0	86	71	56	12.8	2.6	0.52	0.9	0.45	0.23
		240	MS0	83	69	54	9.8	2	0.4	0.8	0.4	0.2
		180	MS30	79	65	51	4.5	0.9	0.18	0.6	0.3	0.15
		120	MS30	75	61	46	1.9	0.4	0.07	0.4	0.2	0.1
36°	10 ¹	270	MS0	86	71	56	16	3.3	0.65	0.9	0.45	0.23
		240	MS0	83	69	54	12.2	2.5	0.5	0.8	0.4	0.2
		180	MS30	79	65	51	5.7	1.2	0.23	0.6	0.3	0.15
		120	MS30	75	61	46	2.4	0.5	0.09	0.4	0.2	0.1
30°	12 ²	240	MS0	62	51	39	11	2.3	0.43	0.8	0.4	0.2

¹) Parallel drives with stop numbers 6, 8 and 10 are designed as a double index, i.e. with each full rotation of the drive shaft, two indexes occur in the output.

²) Parallel drives with 12 stops are designed as a four step index, i.e. with each full rotation of the drive shaft, four indexes occur in the output.

³) The additional load occurring with chains and belts due to friction is not taken into consideration here and must be calculated separately.

Main Dimensions

Shaft distance [mm]	63
Weight without drive [kg]	8
Switching angle [°]	see Load Table
(other switching angles upon request)	
Number of stops	1,2,3,4,5,6,8,10,12
(other numbers of stops upon request)	
Rotating direction	right, left, oscillating
Mounting position	ANY

Capacities

Max. Output torque	See Load Table
Input Shaft	
Load rating dynamic [kN]	11.9
Load rating static [kN]	6.55
Output Shaft	
Load rating dynamic [kN]	8.06
Load rating static [kN]	4.75

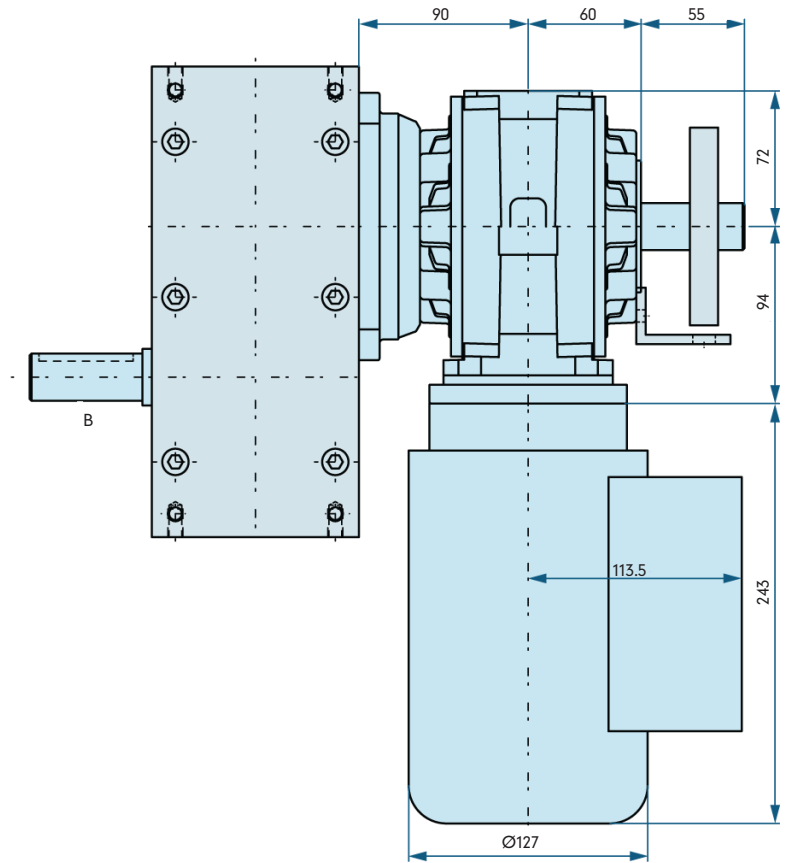
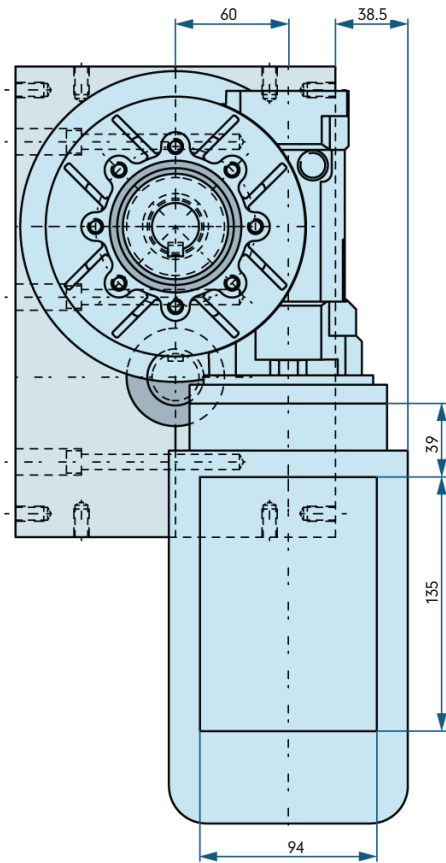
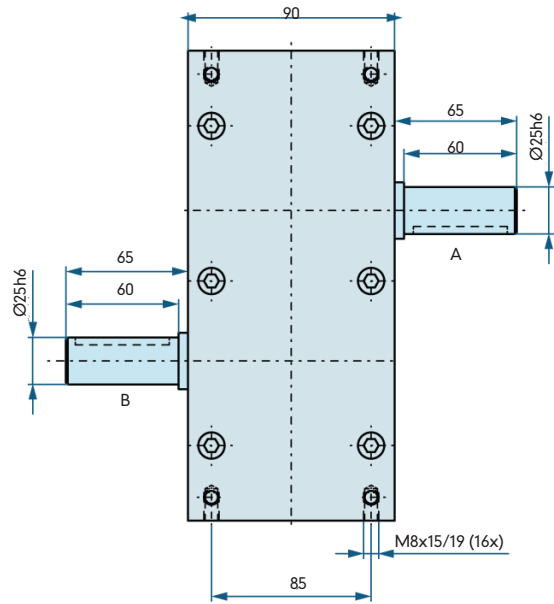
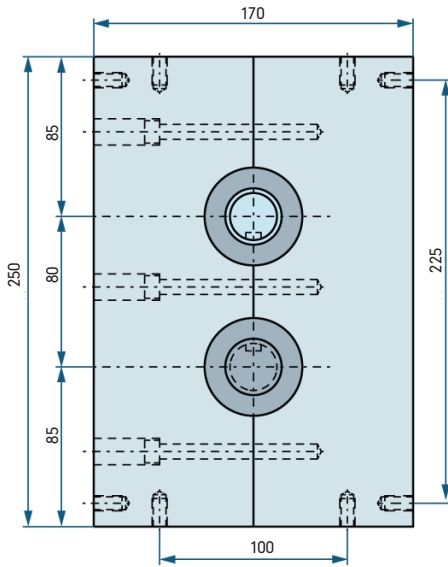

TP080 Dimensions

The measurements shown here illustrate the standard unit. We will gladly customize the housing and or shaft(s) to suit your needs. The drive shaft as well as the output shaft are available as double sided shafts with and without keyways. If you would like to add additional holes into the housing yourself, please contact us for possible drilling depths.

A = Drive Shaft

B = Output Shaft



The dimensions for the gearmotor may change based on the gearmotor size and options required for the application.

TP080 Load Table

Angle on Output Shaft [°]	Number of Stops n	Index Angle [°]	Acceleration Form MS	Indexer Torque M_{AB} [Nm]			Moment of Inertia J [kgm ²]			Mechanical Index Time t_s [S]		
				n=50	n=100	n=200	n=50	n=100	n=200	n=50	n=100	n=200
360°	1	330	MS30	124	102	81	2.4	0.5	0.1	1.1	0.55	0.28
		300	MS50	123	101	79	2.4	0.5	0.1	1	0.5	0.25
180°	2	270	MS0	132	107	93	4.2	0.9	0.19	0.9	0.45	0.23
		210	MS30	131	107	93	3	0.6	0.13	0.7	0.35	0.18
		150	MS50	103	96	89	0.8	0.2	0.04	0.5	0.25	0.13
120°	3	270	MS0	159	137	112	8.9	1.9	0.39	0.9	0.45	0.23
		210	MS30	152	129	101	4.4	0.9	0.18	0.7	0.35	0.18
		150	MS30	127	103	83	1.9	0.4	0.08	0.5	0.25	0.13
		120	MS30	119	97	78	1.1	0.2	0.05	0.4	0.2	0.1
90°	4	270	MS0	157	132	109	11.7	2.5	0.51	0.9	0.45	0.23
		210	MS0	151	126	96	6.8	1.4	0.27	0.7	0.35	0.18
		150	MS30	138	112	88	2.7	0.6	0.11	0.5	0.25	0.13
		90	MS30	118	92	76	0.8	0.2	0.03	0.3	0.15	0.08
72°	5	270	MS0	157	132	109	14.6	3.1	0.64	0.9	0.45	0.23
		210	MS0	151	126	96	8.5	1.8	0.34	0.7	0.35	0.18
		150	MS30	138	112	88	3.4	0.7	0.14	0.5	0.25	0.13
		90	MS30	118	92	76	1.1	0.2	0.04	0.3	0.15	0.08
60°	6 ¹	270	MS0	186	149	124	20.8	4.2	0.87	0.9	0.45	0.23
		240	MS0	174	146	120	15.4	3.2	0.66	0.8	0.4	0.2
		180	MS30	160	122	96	6.9	1.3	0.26	0.6	0.3	0.15
		120	MS30	132	105	81	2.5	0.5	0.1	0.4	0.2	0.1
45°	8 ¹	270	MS0	186	149	124	27.8	5.6	1.16	0.9	0.45	0.23
		240	MS0	174	146	120	20.5	4.3	0.88	0.8	0.4	0.2
		180	MS30	160	122	96	9.2	1.7	0.34	0.6	0.3	0.15
		120	MS30	132	105	81	3.4	0.7	0.13	0.4	0.2	0.1
36°	10 ¹	270	MS0	186	149	124	34.7	7	1.45	0.9	0.45	0.23
		240	MS0	174	146	120	25.7	5.4	1.11	0.8	0.4	0.2
		180	MS30	160	122	96	11.4	2.2	0.43	0.6	0.3	0.15
		120	MS30	132	105	81	4.2	0.8	0.16	0.4	0.2	0.1
30°	12 ²	240	MS0	110	95	76	19.5	4.2	0.84	0.8	0.4	0.2

¹) Parallel drives with stop numbers 6, 8 and 10 are designed as a double index, i.e. with each full rotation of the drive shaft, two indexes occur in the output.

²) Parallel drives with 12 stops are designed as a four step index, i.e. with each full rotation of the drive shaft, four indexes occur in the output.

³) The additional load occurring with chains and belts due to friction is not taken into consideration here and must be calculated separately.

Main Dimensions

Shaft distance [mm]	80
Weight without drive [kg]	16
Switching angle [°]	see Load Table
(other switching angles upon request)	
Number of stops	1,2,3,4,5,6,8,10,12
(other numbers of stops upon request)	
Rotating direction	right, left, oscillating
Mounting position	ANY

Capacities

Max. Output torque	See Load Table
Input Shaft	
Load rating dynamic [kN]	13.8
Load rating static [kN]	8.3
Output Shaft	
Load rating dynamic [kN]	13.8
Load rating static [kN]	8.3

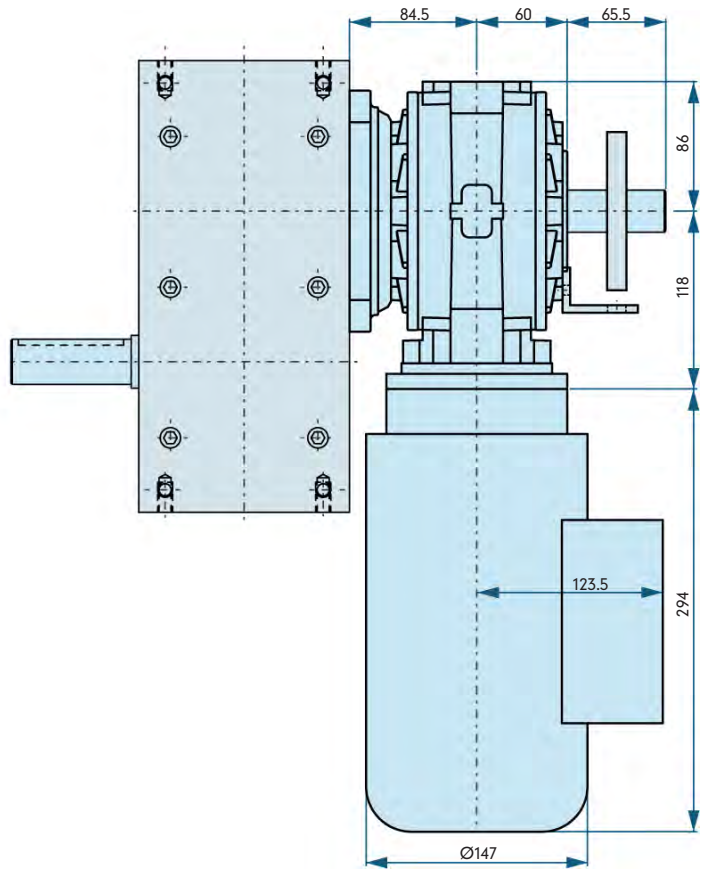
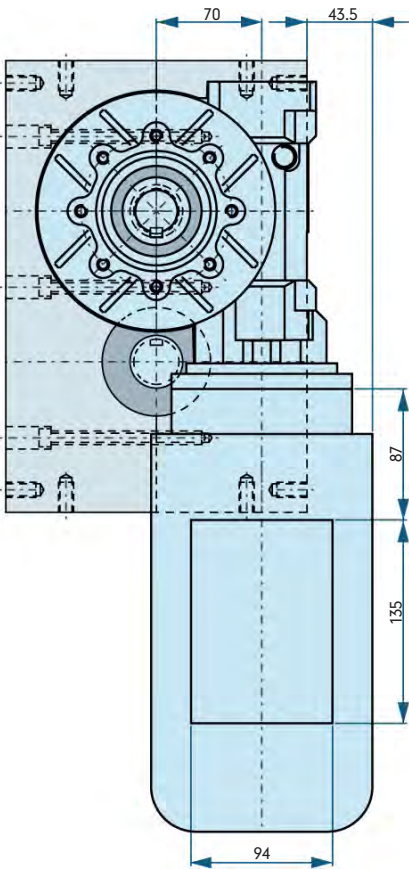
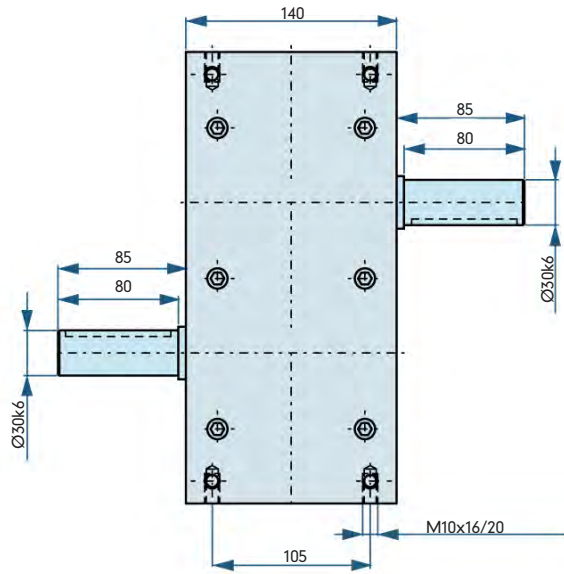
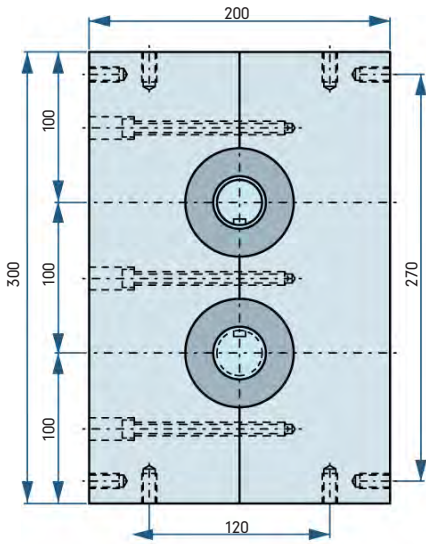

TP100 Dimensions

The measurements shown here illustrate the standard unit. We will gladly customize the housing and or shaft(s) to suit your needs. The drive shaft as well as the output shaft are available as double sided shafts with and without keyways. If you would like to add additional holes into the housing yourself, please contact us for possible drilling depths.

A = Drive Shaft

B = Output Shaft



The dimensions for the gearmotor may change based on the gearmotor size and options required for the application.

TP100 Load Table

Angle on Output Shaft [°]	Number of Stops n	Index Angle [°]	Acceleration Form MS	Indexer Torque M_{AB} [Nm]			Moment of Inertia J [kgm ²]			Mechanical Index Time t_s [S]		
				n=50	n=100	n=200	n=50	n=100	n=200	n=50	n=100	n=200
360°	1	330	MS30	211	171	135	4.1	0.8	0.2	1.1	0.55	0.28
		300	MS50	203	167	129	4	0.8	0.2	1	0.5	0.25
180°	2	270	MS0	290	259	225	9.3	2.1	0.5	0.9	0.45	0.23
		210	MS30	278	245	216	6.3	1.4	0.3	0.7	0.35	0.18
		150	MS50	248	199	151	2	0.4	0.1	0.5	0.25	0.13
120°	3	270	MS0	353	312	272	19.7	4.4	1	0.9	0.45	0.23
		210	MS30	342	305	264	10	2.2	0.5	0.7	0.35	0.18
		150	MS30	336	299	255	5	1.1	0.2	0.5	0.25	0.13
		120	MS30	332	294	250	3.2	0.7	0.1	0.4	0.2	0.1
90°	4	270	MS0	333	291	239	24.9	5.4	1.1	0.9	0.45	0.23
		210	MS0	322	284	233	14.6	3.2	0.7	0.7	0.35	0.18
		150	MS30	311	273	221	6.2	1.4	0.3	0.5	0.25	0.13
		90	MS30	285	263	216	2	0.5	0.1	0.3	0.15	0.08
72°	5	270	MS0	333	291	239	31.1	6.8	1.4	0.9	0.45	0.23
		210	MS0	322	284	233	18.2	4	0.8	0.7	0.35	0.18
		150	MS30	311	273	221	7.7	1.7	0.3	0.5	0.25	0.13
		90	MS30	285	263	216	2.6	0.6	0.1	0.3	0.15	0.08
60°	6 ¹	270	MS0	382	343	291	42.8	9.6	2	0.9	0.45	0.23
		240	MS0	368	331	279	32.6	7.3	1.5	0.8	0.4	0.2
		180	MS30	298	254	197	12.8	2.7	0.5	0.6	0.3	0.15
		120	MS30	275	234	176	5.2	1.1	0.2	0.4	0.2	0.1
45°	8 ¹	270	MS0	382	343	291	57	12.8	2.7	0.9	0.45	0.23
		240	MS0	368	331	279	43.4	9.8	2.1	0.8	0.4	0.2
		180	MS30	298	254	197	7	1.5	0.3	0.6	0.3	0.15
		120	MS30	275	234	176	7	1.5	0.3	0.4	0.2	0.1
36°	10 ¹	270	MS0	382	343	291	71.3	16	3.4	0.9	0.45	0.23
		240	MS0	368	331	279	54.3	12.2	2.6	0.8	0.4	0.2
		180	MS30	298	254	197	21.3	4.5	0.9	0.6	0.3	0.15
		120	MS30	275	234	176	8.7	1.9	0.3	0.4	0.2	0.1
30°	12 ²	240	MS0	264	215	166	46.7	9.5	1.8	0.8	0.4	0.2

¹) Parallel drives with stop numbers 6, 8 and 10 are designed as a double index, i.e. with each full rotation of the drive shaft, two indexes occur in the output.

²) Parallel drives with 12 stops are designed as a four step index, i.e. with each full rotation of the drive shaft, four indexes occur in the output.

³) The additional load occurring with chains and belts due to friction is not taken into consideration here and must be calculated separately.

Main Dimensions

Shaft distance [mm]	100
Weight without drive [kg]	25
Switching angle [°]	see Load Table
(other switching angles upon request)	
Number of stops	1,2,3,4,5,6,8,10,12
(other numbers of stops upon request)	
Rotating direction	right, left, oscillating
Mounting position	ANY

Capacities

Max. Output torque	See Load Table
Input Shaft	
Load rating dynamic [kN]	40
Load rating static [kN]	28
Output Shaft	
Load rating dynamic [kN]	40
Load rating static [kN]	28

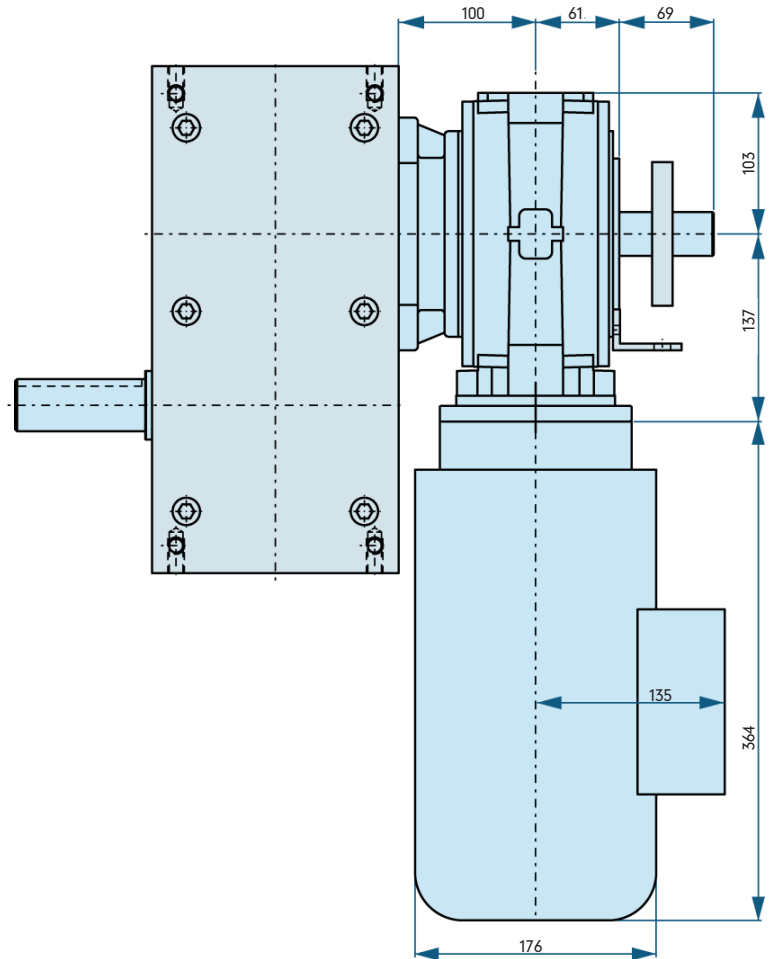
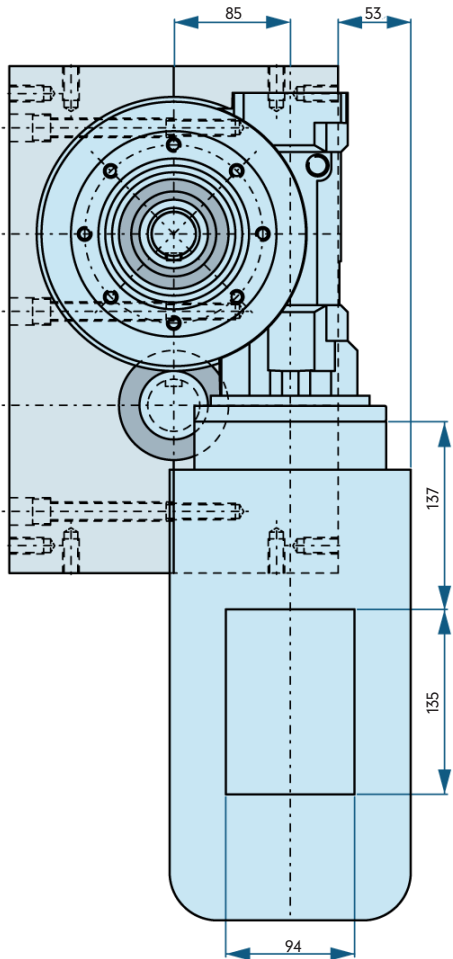
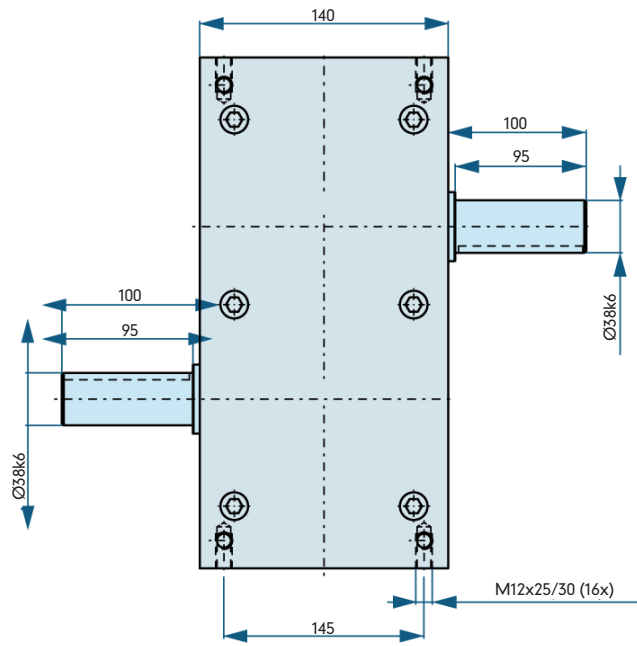
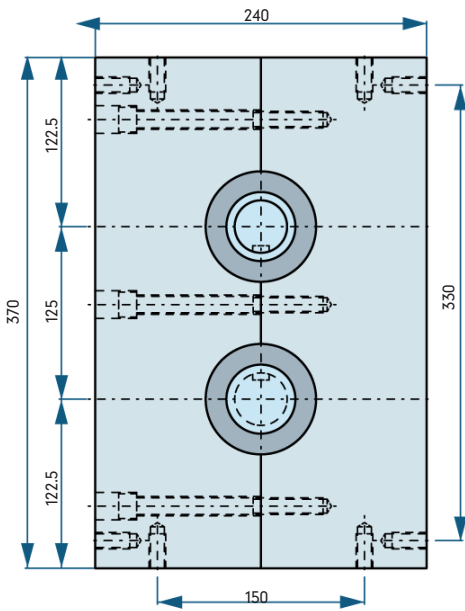

TP125 Dimensions

The measurements shown here illustrate the standard unit. We will gladly customize the housing and or shaft(s) to suit your needs. The drive shaft as well as the output shaft are available as double sided shafts with and without keyways. If you would like to add additional holes into the housing yourself, please contact us for possible drilling depths.

A = Drive Shaft

B = Output Shaft



The dimensions for the gearmotor may change based on the gearmotor size and options required for the application.

TP125 Load Table

Angle on Output Shaft [°]	Number of Stops n	Index Angle [°]	Acceleration Form MS	Indexer Torque M_{AB} [Nm]			Moment of Inertia J [kgm ²]			Mechanical Index Time t_s [S]		
				n=50	n=100	n=200	n=50	n=100	n=200	n=50	n=100	n=200
360°	1	330	MS30	349	282	221	6.7	1.4	0.3	1.1	0.55	0.28
		300	MS50	340	270	204	6.8	1.3	0.3	1	0.5	0.25
180°	2	270	MS0	436	360	294	14.1	2.9	0.6	0.9	0.45	0.23
		210	MS30	362	275	207	8.2	1.6	0.3	0.7	0.35	0.18
		150	MS50	301	222	160	2.4	0.4	0.1	0.5	0.25	0.13
120°	3	270	MS0	538	447	365	30.1	6.3	1.3	0.9	0.45	0.23
		210	MS30	505	424	350	14.8	3.1	0.6	0.7	0.35	0.18
		150	MS30	403	321	233	6	1.2	0.2	0.5	0.25	0.13
		120	MS30	379	277	204	3.6	0.7	0.1	0.4	0.2	0.1
90°	4	270	MS0	525	442	350	39.2	8.3	1.6	0.9	0.45	0.23
		210	MS0	487	401	316	22	4.5	0.9	0.7	0.35	0.18
		150	MS30	467	379	286	9.3	1.9	0.4	0.5	0.25	0.13
		90	MS30	428	336	256	3.1	0.6	0.1	0.3	0.15	0.08
72°	5	270	MS0	525	442	350	49	10.3	2	0.9	0.45	0.23
		210	MS0	487	401	316	27.5	5.7	1.1	0.7	0.35	0.18
		150	MS30	467	379	256	3.8	0.8	0.1	0.5	0.25	0.13
		90	MS30	428	336	256	3.8	0.8	0.1	0.3	0.15	0.08
60°	6 ¹	270	MS0	598	522	430	66.9	14.6	3	0.9	0.45	0.23
		240	MS0	560	469	379	49.5	10.4	2.1	0.8	0.4	0.2
		180	MS30	433	358	272	18.6	3.8	0.7	0.6	0.3	0.15
		120	MS30	384	311	232	7.3	1.5	0.3	0.4	0.2	0.1
45°	8 ¹	270	MS0	598	522	430	89.2	19.5	4	0.9	0.45	0.23
		240	MS0	560	469	379	66	13.8	2.8	0.8	0.4	0.2
		180	MS30	433	358	272	24.8	5.1	1	0.6	0.3	0.15
		120	MS30	384	311	232	9.8	2	0.4	0.4	0.2	0.1
36°	10 ¹	270	MS0	598	522	430	111.5	24.3	5	0.9	0.45	0.23
		240	MS0	560	469	379	82.5	17.3	3.5	0.8	0.4	0.2
		180	MS30	433	358	272	30.9	6.4	1.2	0.6	0.3	0.15
		120	MS30	384	311	232	12.2	2.5	0.5	0.4	0.2	0.1
30°	12 ²	240	MS0	350	282	224	61.9	12.5	2.5	0.8	0.4	0.2

¹) Parallel drives with stop numbers 6, 8 and 10 are designed as a double index, i.e. with each full rotation of the drive shaft, two indexes occur in the output.

²) Parallel drives with 12 stops are designed as a four step index, i.e. with each full rotation of the drive shaft, four indexes occur in the output.

³) The additional load occurring with chains and belts due to friction is not taken into consideration here and must be calculated separately.

Main Dimensions

Shaft distance [mm]	125
Weight without drive [kg]	12
Switching angle [°]	see Load Table
(other switching angles upon request)	
Number of stops	1,2,3,4,5,6,8,10,12
(other numbers of stops upon request)	
Rotating direction	right, left, oscillating
Mounting position	ANY

Capacities

Max. Output torque	See Load Table
Input Shaft	
Load rating dynamic [kN]	51
Load rating static [kN]	39
Output Shaft	
Load rating dynamic [kN]	51
Load rating static [kN]	39

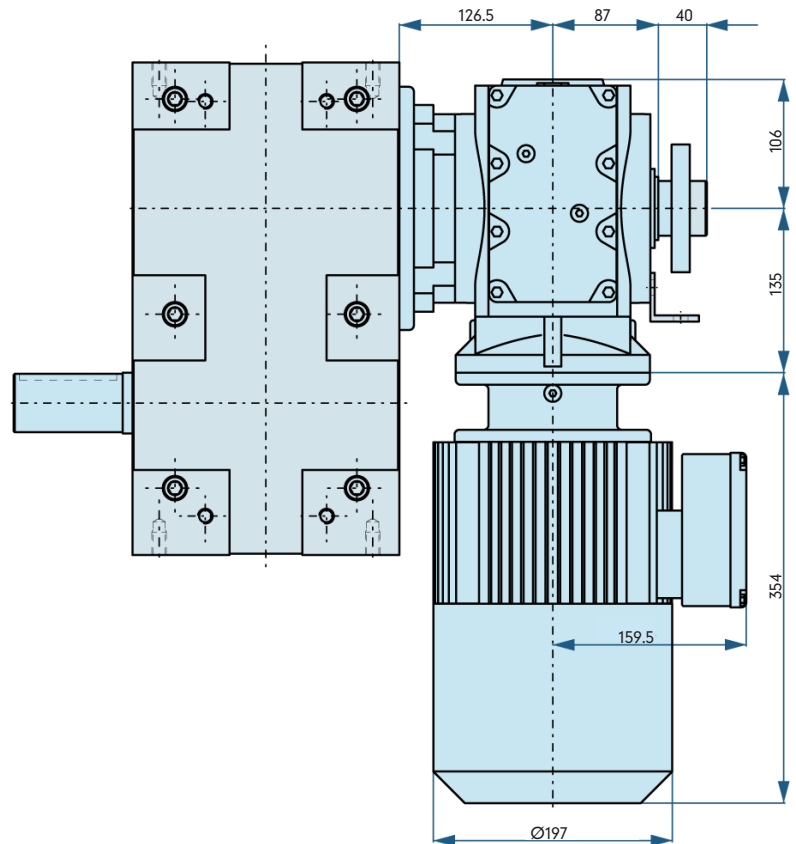
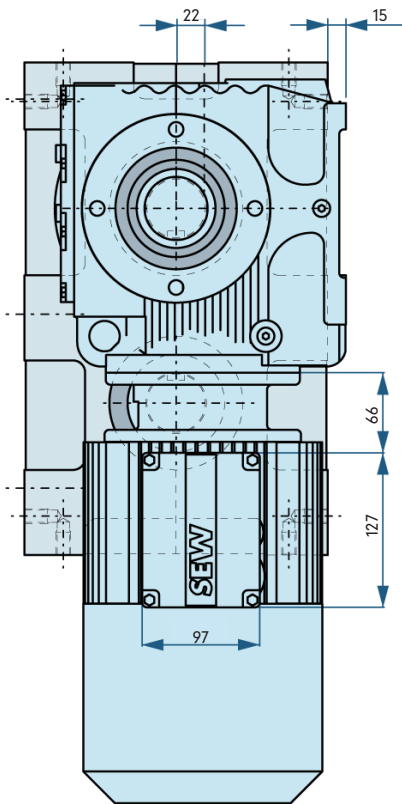
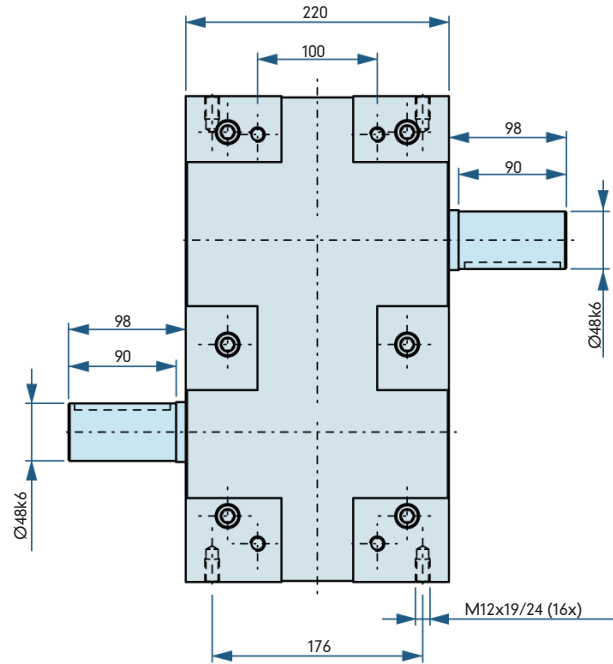
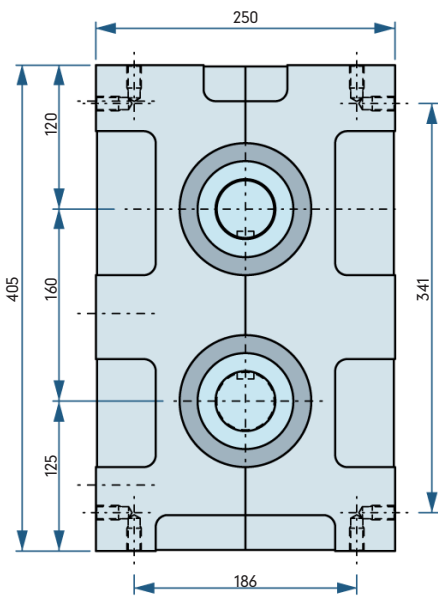

TP160 Dimensions

The measurements shown here illustrate the standard unit. We will gladly customize the housing and or shaft(s) to suit your needs. The drive shaft as well as the output shaft are available as double sided shafts with and without keyways. If you would like to add additional holes into the housing yourself, please contact us for possible drilling depths.

A = Drive Shaft

B = Output Shaft



The dimensions for the gearmotor may change based on the gearmotor size and options required for the application.

TP160 Load Table

Angle on Output Shaft [°]	Number of Stops n	Index Angle [°]	Acceleration Form MS	Indexer Torque M_{AB} [Nm]			Moment of Inertia J [kgm ²]			Mechanical Index Time t_s [S]		
				n=50	n=100	n=200	n=50	n=100	n=200	n=50	n=100	n=200
360°	1	330	MS30	894	739	598	17.2	3.6	0.7	1.1	0.55	0.28
		300	MS50	865	714	564	17.2	3.5	0.7	1	0.5	0.25
180°	2	270	MS0	904	816	661	29.1	6.6	1.3	0.9	0.45	0.23
		210	MS30	782	758	612	17.7	4.3	0.9	0.7	0.35	0.18
		150	MS50	768	719	583	6.1	1.4	0.3	0.5	0.25	0.13
120°	3	270	MS0	923	894	661	51.7	12.5	2.3	0.9	0.45	0.23
		210	MS30	816	787	573	23.9	5.8	1	0.7	0.35	0.18
		150	MS30	797	768	554	11.9	2.9	0.5	0.5	0.25	0.13
		120	MS30	782	748	525	7.5	1.8	0.3	0.4	0.2	0.1
90°	4	270	MS0	923	894	661	68.9	16.7	3.1	0.9	0.45	0.23
		210	MS0	816	787	573	36.9	8.9	1.6	0.7	0.35	0.18
		150	MS30	797	768	554	15.8	3.8	0.7	0.5	0.25	0.13
		90	MS30	782	748	525	5.6	1.3	0.2	0.3	0.15	0.08
72°	5	270	MS0	923	894	661	86.1	20.9	3.9	0.9	0.45	0.23
		210	MS0	816	787	573	46.1	11.1	2	0.7	0.35	0.18
		150	MS30	797	768	554	19.8	4.8	0.9	0.5	0.25	0.13
		90	MS30	782	748	525	7	1.7	0.3	0.3	0.15	0.08
60°	6 ¹	270	MS0	904	894	865	101.2	25	6.1	0.9	0.45	0.23
		240	MS0	885	875	846	78.2	19.3	4.7	0.8	0.4	0.2
		180	MS30	865	855	826	37.1	9.2	2.2	0.6	0.3	0.15
		120	MS30	836	816	797	15.9	3.9	1	0.4	0.2	0.1
45°	8 ¹	270	MS0	768	748	729	114.6	27.9	6.8	0.9	0.45	0.23
		240	MS0	748	729	710	88.3	21.5	5.2	0.8	0.4	0.2
		180	MS30	739	719	690	42.3	10.3	2.5	0.6	0.3	0.15
		120	MS30	729	710	700	18.5	4.5	1.1	0.4	0.2	0.1
36°	10 ¹	270	MS0	768	748	729	143.3	34.9	8.5	0.9	0.45	0.23
		240	MS0	748	729	710	110.3	26.9	6.5	0.8	0.4	0.2
		180	MS30	739	719	690	52.9	12.9	3.1	0.6	0.3	0.15
		120	MS30	729	710	700	23.2	5.6	1.4	0.4	0.2	0.1
30°	12 ²	240	MS0	710	700	680	125.5	31	7.5	0.8	0.4	0.2

¹) Parallel drives with stop numbers 6, 8 and 10 are designed as a double index, i.e. with each full rotation of the drive shaft, two indexes occur in the output.

²) Parallel drives with 12 stops are designed as a four step index, i.e. with each full rotation of the drive shaft, four indexes occur in the output.

³) The additional load occurring with chains and belts due to friction is not taken into consideration here and must be calculated separately.

Main Dimensions

Shaft distance [mm]	160
Weight without drive [kg]	117
Switching angle [°]	see Load Table
(other switching angles upon request)	
Number of stops	1,2,3,4,5,6,8,10,12
(other numbers of stops upon request)	
Rotating direction	right, left, oscillating
Mounting position	ANY

Capacities

Max. Output torque	See Load Table
Input Shaft	
Load rating dynamic [kN]	51
Load rating static [kN]	39
Output Shaft	
Load rating dynamic [kN]	168
Load rating static [kN]	270



MOTION INDEX DRIVES

RIGHT ANGLE DRIVES
TG Series

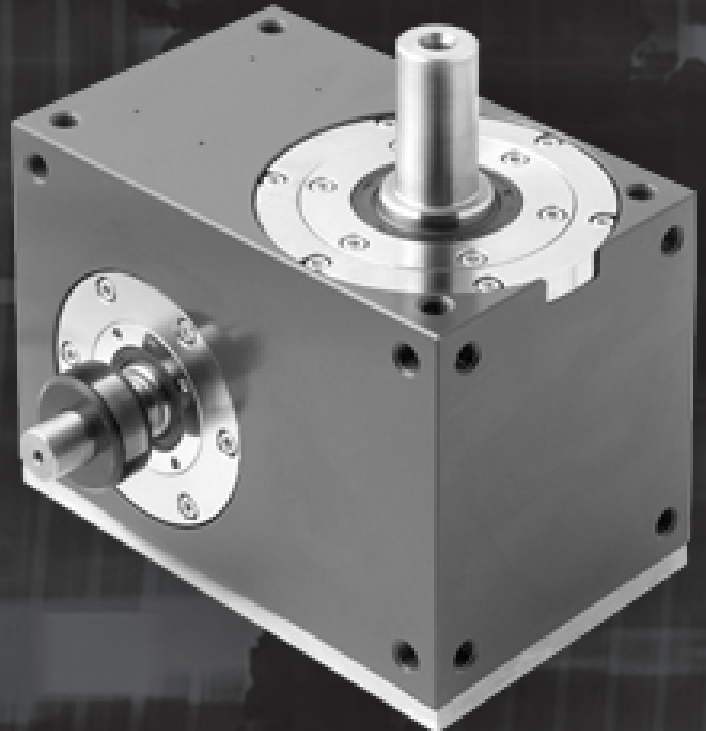



MOTION INDEX DRIVES



Right Angle Fixed Index Drives – TG Series

The rotary index table transforms a constant input drive motion into an intermittent output drive motion. The intermittent drive motion occurs by means of a hardened and high accuracy globoidal cam. The use of mathematical laws of motion guarantees a soft, shock-proof, and jerk free movement that has been optimally designed for its intended purpose. The design allows for accurate and secure mounting to the output dial. The preload of the cam to the cam followers in dwell ensures the top dial is backlash free. No additional adjustment of the output dial is necessary. Globoidal Cams are a cam design used in which the cam followers are mounted radially outward from the outside diameter of the output shaft. The input shaft is perpendicular to the output shaft. The diameter of the cam allows for very special index angles, which allows for a large variety of output angles, which is extremely beneficial in continuously running, mechanically synchronous machines. The globoidal cam also is beneficial for very high speed applications, as the internal inertia of the cam design is the lowest of all the different cam designs.

The power is provided either by means of a three-phase motor via a gear reducer or by means of a timing chain/belt on the input shaft of the rotary index drive. This is firmly connected to the globoidal cam, without any further internal gear sets, and it turns the cam followers and subsequently the output flange. The output dial is mounted to a set of tapered roller bearings, which is preloaded to eliminate any runout. The index drive is completely sealed to eliminate intrusion from foreign particulate.

TG Series Right Angle Drive

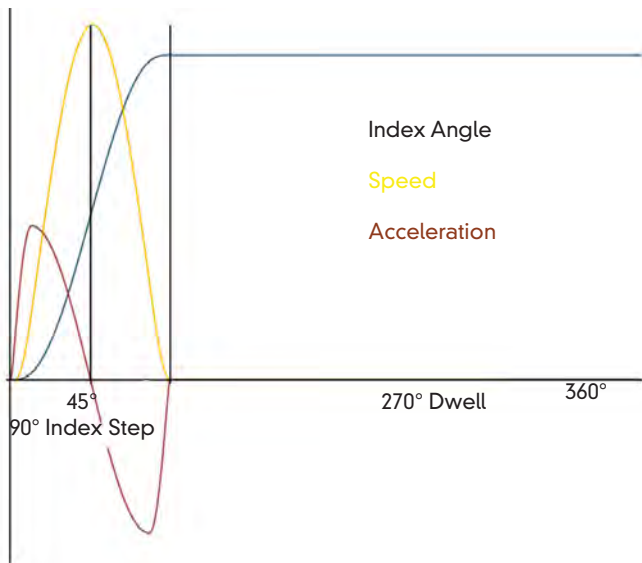

Advantages for design engineers and special machine builder

- Housing machined on all sides. Suitable for use in any mounting position required.
- Mounting holes identical on top and bottom.
- Smooth index angles and extended dwell enable continuous use.
- Globoidal design enables up to 100 cycles per minute.
- Simultaneously rotating input shaft extension.
- Optional synchronization of other mechanical modules.

Options for individual customer requirements

- Choice of drive units/gear motor.
- Units can be driven directly with gear motor or indirectly with customer timing belt/chain/shaft.
- Optional friction clutch on drive.
- Dwell and step angle can be tailored to requirements.
- Custom specified color at no extra charge.

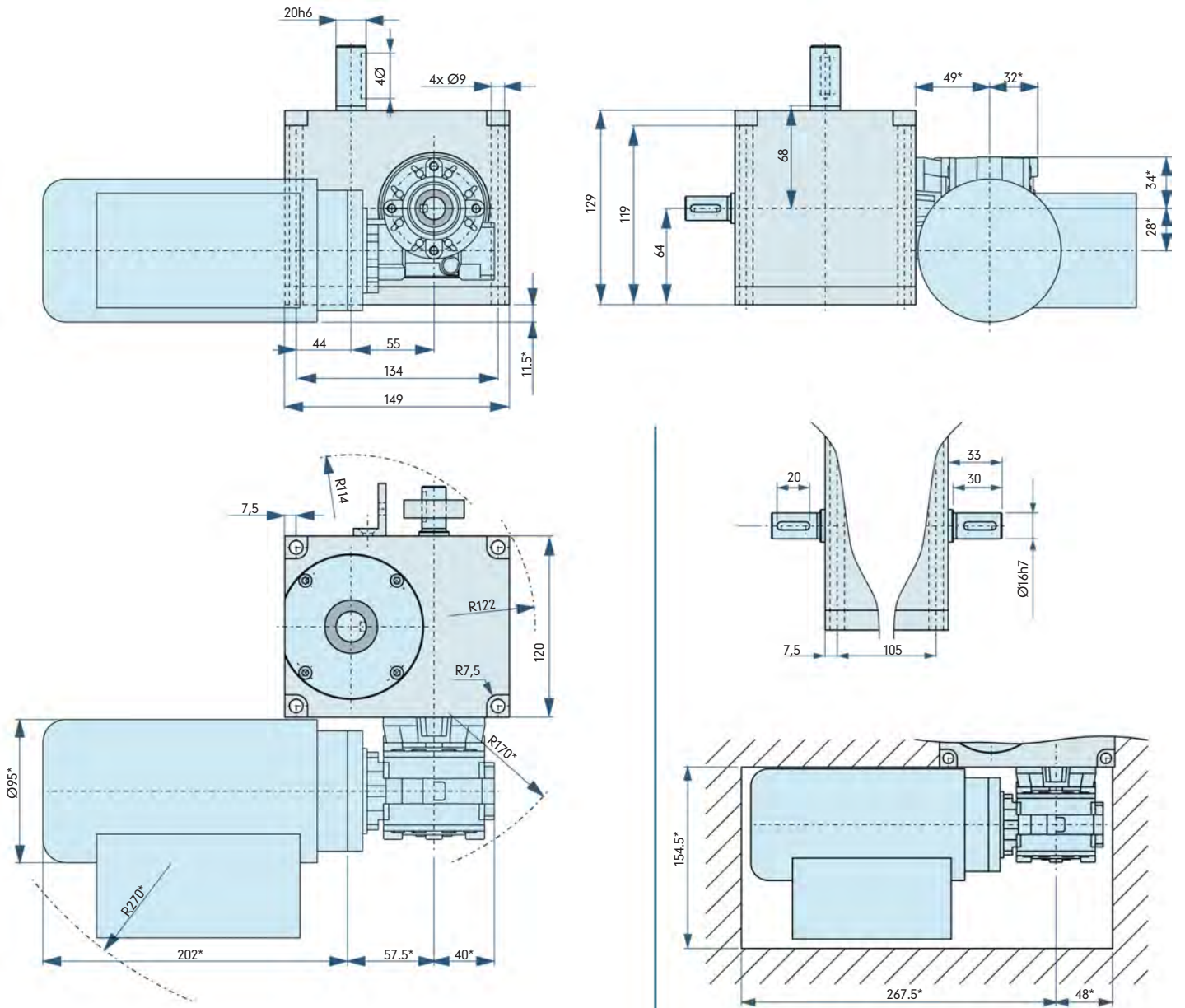

TG055 Dimensions

The measurements shown here illustrate the standard unit. We will gladly customize the housing, shaft(s) and/or output flange to suit your needs. The drive shaft as well as the output shaft (if applicable) are available as double sided shafts with and without keyways. If you would like to add additional holes into the housing yourself, please contact us for possible drilling depths.



The dimensions for the gearmotor may change based on the gearmotor size and options required for the application.

TG055 Load Table

Angle on Output Shaft [°]	Number of Stops n	Index Angle [°]	Acceleration Form MS	Indexer Torque M_{AB} [Nm]			Moment of Inertia J [kgm ²]			Mechanical Index Time t_s [S]		
				n=50	n=100	n=200	n=50	n=100	n=200	n=50	n=100	n=200
360°	1	330	MS30	13	10	9	0.25	0.05	0.01	1.1	0.55	0.28
		300	MS50	13	10	9	0.26	0.05	0.01	1	0.5	0.25
180°	2	270	MS0	13	11	9	0.42	0.09	0.02	0.9	0.45	0.23
		210	MS30	13	10	8	0.29	0.06	0.01	0.7	0.35	0.18
		150	MS50	13	10	8	0.1	0.02	0	0.5	0.25	0.13
120°	3	270	MS0	17	14	12	0.95	0.2	0.04	0.9	0.45	0.23
		210	MS30	17	14	12	0.5	0.1	0.02	0.7	0.32	0.18
		150	MS30	16	13	11	0.24	0.05	0.01	0.5	0.25	0.13
		120	MS30	16	13	11	0.15	0.03	0.01	0.4	0.2	0.1
90°	4	270	MS0	13	13	11	0.97	0.24	0.05	0.9	0.45	0.23
		210	MS0	13	13	11	0.59	0.15	0.03	0.7	0.35	0.18
		150	MS30	12	12	10	0.24	0.06	0.01	0.5	0.25	0.13
		90	MS30	11	11	9	0.08	0.02	0	0.3	0.15	0.08
72°	5	270	MS0	13	13	11	1.21	0.3	0.06	0.9	0.45	0.23
		210	MS0	13	13	11	0.73	0.18	0.04	0.7	0.35	0.18
		150	MS30	12	12	10	0.3	0.07	0.02	0.5	0.25	0.13
		90	MS30	11	11	9	0.1	0.02	0.01	0.3	0.15	0.08
60°	6 ¹⁾	270	MS0	16	16	12	1.79	0.45	0.08	0.9	0.45	0.23
		240	MS0	16	16	12	1.42	0.35	0.07	0.8	0.4	0.2
		180	MS30	15	15	11	0.64	0.16	0.03	0.6	0.3	0.15
		120	MS30	13	13	10	0.25	0.06	0.01	0.4	0.2	0.1
45°	8 ¹⁾	270	MS0	12	12	11	1.79	0.45	0.1	0.9	0.45	0.23
		240	MS0	12	12	11	1.42	0.35	0.08	0.8	0.4	0.2
		180	MS30	12	12	11	0.69	0.17	0.04	0.6	0.3	0.15
		120	MS30	11	11	10	0.28	0.07	0.02	0.4	0.2	0.1

¹⁾ Right angle drives with stop numbers 6, 8 and 10 are designed as a double index, i.e. with each full rotation of the drive shaft, two indexes occur in the output.

²⁾ Right angle drives with 12 stops are designed as a four step index, i.e. with each full rotation of the drive shaft, four indexes occur in the output.

³⁾ The additional load occurring with chains and belts due to friction is not taken into consideration here and must be calculated separately.

Main Dimensions

Shaft distance [mm]	55
Weight without drive [kg]	10
Switching angle [°]	see Load Table
(other switching angles upon request)	
Number of stops	1,2,3,4,5,6,8,10
(other numbers of stops upon request)	
Rotating direction	right, left, oscillating
Mounting position	ANY

Capacities

Max. Output torque	See Load Table
Input Shaft	
Load rating dynamic [kN]	N/A
Load rating static [kN]	N/A
Output Shaft	
Load rating dynamic [kN]	N/A
Load rating static [kN]	N/A

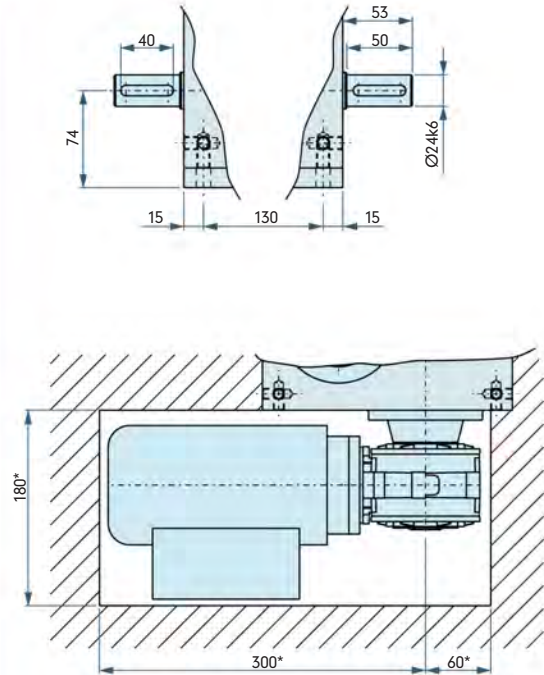
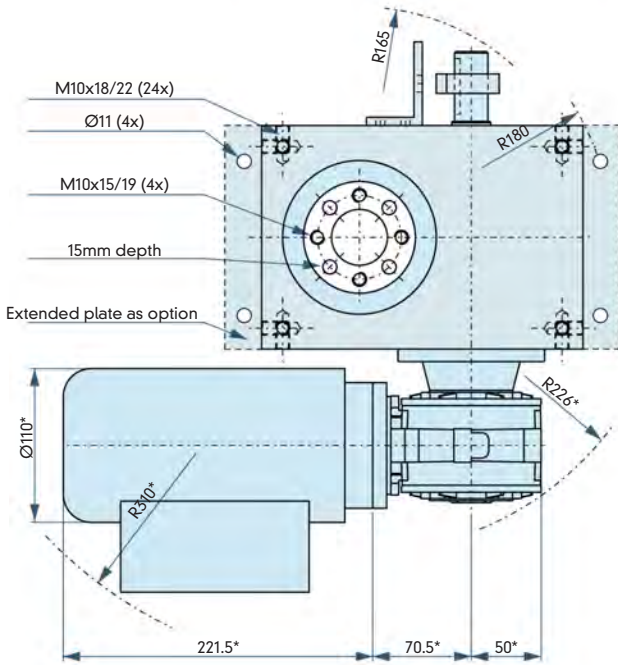
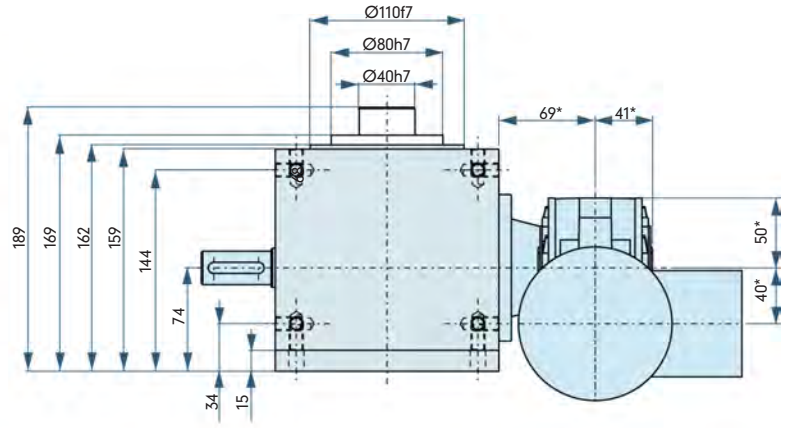
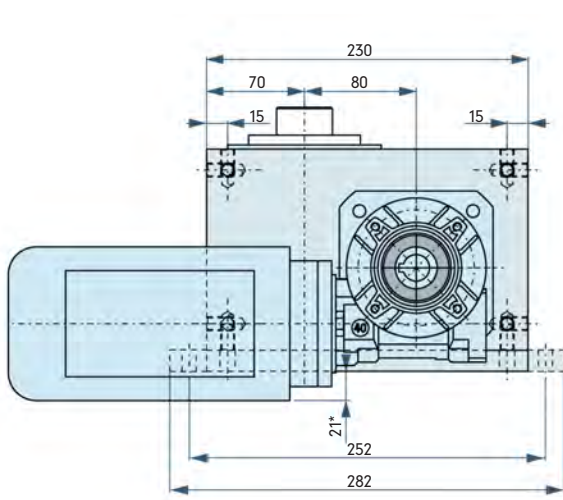

TG080 Dimensions

The measurements shown here illustrate the standard unit. We will gladly customize the housing, shaft(s) and/or output flange to suit your needs. The drive shaft as well as the output shaft (if applicable) are available as double sided shafts with and without keyways. If you would like to add additional holes into the housing yourself, please contact us for possible drilling depths.



The dimensions for the gearmotor may change based on the gearmotor size and options required for the application.

TG080 Load Table

Angle on Output Shaft [°]	Number of Stops n	Index Angle [°]	Acceleration Form MS	Indexer Torque M_{AB} [Nm]			Moment of Inertia J [kgm ²]			Mechanical Index Time t_s [S]		
				n=50	n=100	n=200	n=50	n=100	n=200	n=50	n=100	n=200
360°	1	330	MS30	29	25	21	0.56	0.12	0.03	1.1	0.55	0.28
		300	MS50	28	24	20	0.56	0.12	0.02	1	0.5	0.25
180°	2	270	MS0	32	27	24	1.03	0.22	0.05	0.9	0.45	0.23
		210	MS30	26	24	21	0.59	0.14	0.03	0.7	0.35	0.18
		150	MS50	25	23	20	0.2	0.05	0.01	0.5	0.25	0.13
120°	3	270	MS0	39	33	26	2.18	0.46	0.09	0.9	0.45	0.23
		210	MS30	29	33	26	1.14	0.24	0.05	0.7	0.35	0.18
		150	MS30	33	27	23	0.49	0.1	0.02	0.5	0.25	0.13
		120	MS30	30	25	20	0.29	0.06	0.01	0.4	0.2	0.1
90°	4	270	MS0	36	30	24	2.69	0.56	0.11	0.9	0.45	0.23
		210	MS0	36	30	24	1.63	0.34	0.07	0.7	0.35	0.18
		150	MS30	35	29	23	0.7	0.14	0.03	0.5	0.25	0.13
		90	MS30	32	28	21	0.23	0.05	0.01	0.3	0.15	0.08
72°	5	270	MS0	36	30	24	3.36	0.7	0.14	0.9	0.45	0.23
		210	MS0	36	30	24	2.03	0.42	0.08	0.7	0.35	0.18
		150	MS30	35	29	23	0.87	0.18	0.04	0.5	0.25	0.13
		90	MS30	32	28	21	0.29	0.06	0.01	0.3	0.15	0.08
60°	6 ¹⁾	270	MS0	42	34	28	4.7	0.95	0.2	0.9	0.45	0.23
		240	MS0	42	34	28	3.72	0.75	0.15	0.8	0.4	0.2
		180	MS30	40	32	25	1.72	0.34	0.07	0.6	0.3	0.15
		120	MS30	36	29	22	0.69	0.14	0.03	0.4	0.2	0.1
45°	8 ¹⁾	270	MS0	42	34	28	6.27	1.27	0.26	0.9	0.45	0.23
		240	MS0	42	34	28	4.95	1	0.21	0.8	0.4	0.2
		180	MS30	40	32	25	2.29	0.46	0.09	0.6	0.3	0.15
		120	MS30	36	29	22	0.92	0.18	0.03	0.4	0.2	0.1
36°	10 ¹⁾	270	MS0	42	34	28	7.84	1.59	0.33	0.9	0.45	0.23
		240	MS0	42	34	28	6.19	1.25	0.26	0.8	0.4	0.2
		180	MS30	40	32	25	2.86	0.57	0.11	0.6	0.3	0.15
		120	MS30	36	29	22	1.14	0.23	0.04	0.4	0.2	0.1

¹⁾ Right angle drives with stop numbers 6, 8 and 10 are designed as a double index, i.e. with each full rotation of the drive shaft, two indexes occur in the output.

²⁾ Right angle drives with 12 stops are designed as a four step index, i.e. with each full rotation of the drive shaft, four indexes occur in the output.

³⁾ The additional load occurring with chains and belts due to friction is not taken into consideration here and must be calculated separately.

Main Dimensions

Shaft distance [mm]	40
Weight without drive [kg]	20
Switching angle [°]	see Load Table
(other switching angles upon request)	
Number of stops	1,2,3,4,5,6,8,10
(other numbers of stops upon request)	
Rotating direction	right, left, oscillating
Mounting position	ANY

Capacities

Max. Output torque	See Load Table
Input Shaft	
Load rating dynamic [kN]	4.36
Load rating static [kN]	2.24
Output Shaft	
Load rating dynamic [kN]	4.36
Load rating static [kN]	2.24

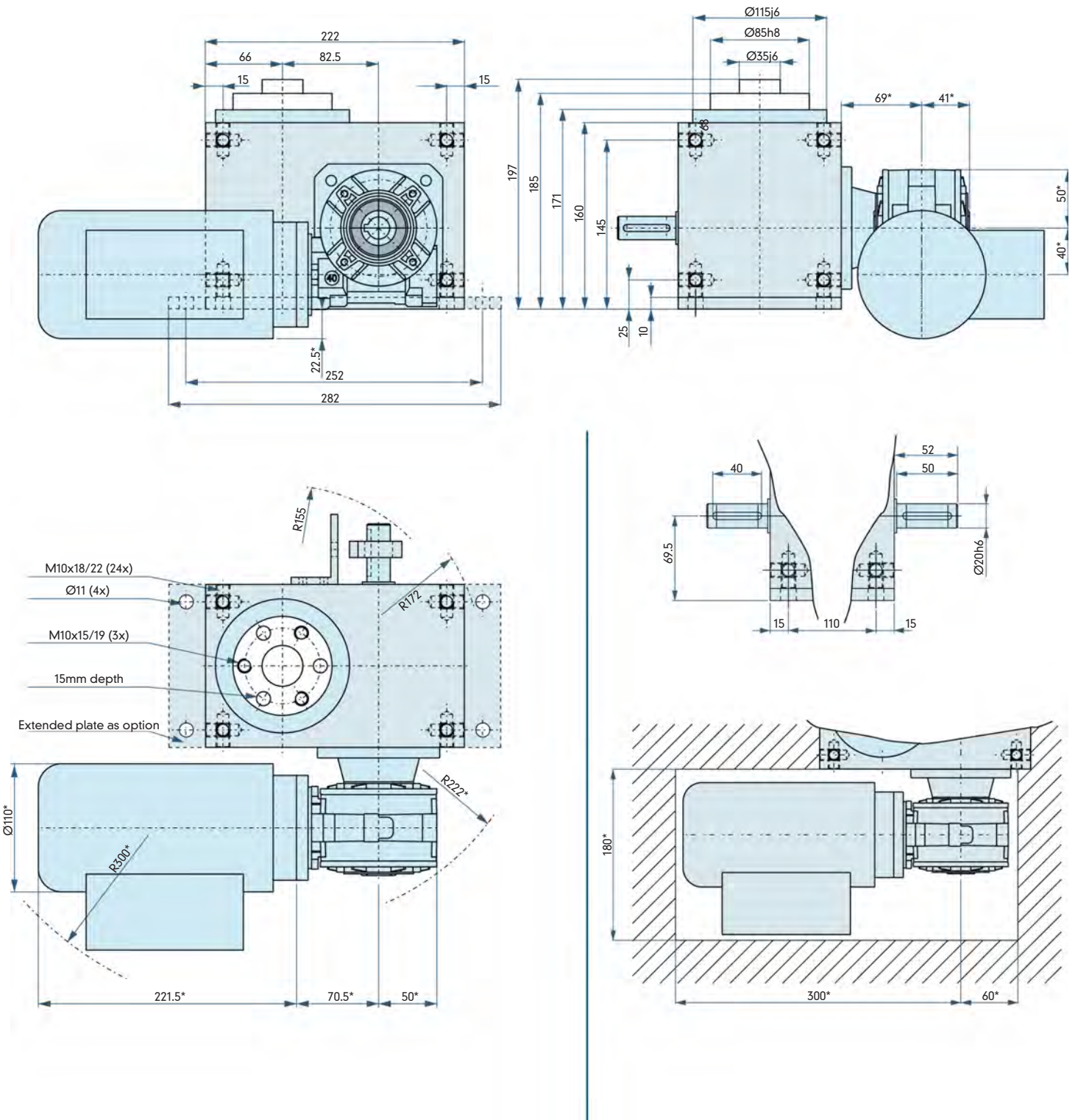

TG082 Dimensions

The measurements shown here illustrate the standard unit. We will gladly customize the housing, shaft(s) and/or output flange to suit your needs. The drive shaft as well as the output shaft (if applicable) are available as double sided shafts with and without keyways. If you would like to add additional holes into the housing yourself, please contact us for possible drilling depths.



The dimensions for the gearmotor may change based on the gearmotor size and options required for the application.

TG082 Load Table

Angle on Output Shaft [°]	Number of Stops n	Index Angle [°]	Acceleration Form MS	Indexer Torque M_{AB} [Nm]			Moment of Inertia J [kgm ²]			Mechanical Index Time t_s [S]		
				n=50	n=100	n=200	n=50	n=100	n=200	n=50	n=100	n=200
360°	1	330	MS30	41	34	29	0.79	0.16	0.03	1.1	0.55	0.28
		300	MS50	41	34	29	0.81	0.17	0.04	1	0.5	0.25
180°	2	270	MS0	51	43	37	1.64	0.35	0.07	0.9	0.45	0.23
		210	MS30	49	42	36	1.11	0.24	0.05	0.7	0.35	0.18
		150	MS50	42	37	34	0.33	0.07	0.02	0.5	0.25	0.13
120°	3	270	MS0	54	49	43	3.02	0.69	0.15	0.9	0.45	0.23
		210	MS30	52	47	42	1.52	0.34	0.08	0.7	0.35	0.18
		150	MS30	45	40	33	0.67	0.15	0.03	0.5	0.25	0.13
		120	MS30	43	37	31	0.41	0.09	0.02	0.4	0.2	0.1
90°	4	270	MS0	47	43	38	3.51	0.8	0.18	0.9	0.45	0.23
		210	MS0	45	41	35	2.54	0.58	0.12	0.7	0.35	0.18
		150	MS30	41	37	31	1.02	0.23	0.05	0.5	0.25	0.13
		90	MS30	37	31	26	0.26	0.06	0.01	0.3	0.15	0.08
72°	5	270	MS0	47	43	38	4.38	1	0.22	0.9	0.45	0.23
		210	MS0	45	41	35	2.54	0.58	0.12	0.7	0.35	0.18
		150	MS30	41	37	31	1.02	0.23	0.05	0.5	0.25	0.13
		90	MS30	37	31	26	0.33	0.07	0.01	0.3	0.15	0.08
60°	6 ¹	270	MS0	59	57	53	6.61	1.6	0.37	0.9	0.45	0.23
		240	MS0	58	54	50	5.13	1.19	0.28	0.8	0.4	0.2
		180	MS30	50	46	41	2.15	0.49	0.11	0.6	0.3	0.15
		120	MS30	47	41	38	0.9	0.2	0.05	0.4	0.2	0.1
45°	8 ¹	270	MS0	59	57	53	8.81	2.13	0.49	0.9	0.45	0.23
		240	MS0	58	54	50	6.84	1.59	0.37	0.8	0.4	0.2
		180	MS30	50	46	41	2.86	0.66	0.15	0.6	0.3	0.15
		120	MS30	47	41	38	1.2	0.26	0.06	0.4	0.2	0.1
36°	10 ¹	270	MS0	59	57	53	11.01	2.66	0.62	0.9	0.45	0.23
		240	MS0	58	54	50	8.55	1.99	0.46	0.8	0.4	0.2
		180	MS30	50	46	41	3.58	0.82	0.18	0.6	0.3	0.15
		120	MS30	47	41	38	1.49	0.33	0.08	0.4	0.2	0.1
30°	12 ²	240	MS0	41	38	31	7.25	1.68	0.34	0.8	0.4	0.2

¹) Right angle drives with stop numbers 6, 8 and 10 are designed as a double index, i.e. with each full rotation of the drive shaft, two indexes occur in the output.

²) Right angle drives with 12 stops are designed as a four step index, i.e. with each full rotation of the drive shaft, four indexes occur in the output.

³) The additional load occurring with chains and belts due to friction is not taken into consideration here and must be calculated separately.

Main Dimensions

Shaft distance [mm]	50
Weight without drive [kg]	25
Switching angle [°]	see Load Table
(other switching angles upon request)	
Number of stops	1,2,3,4,5,6,8,10,12
(other numbers of stops upon request)	
Rotating direction	right, left, oscillating
Mounting position	ANY

Capacities

Max. Output torque	See Load Table
Input Shaft	
Load rating dynamic [kN]	6.37
Load rating static [kN]	3.25
Output Shaft	
Load rating dynamic [kN]	6.37
Load rating static [kN]	3.25

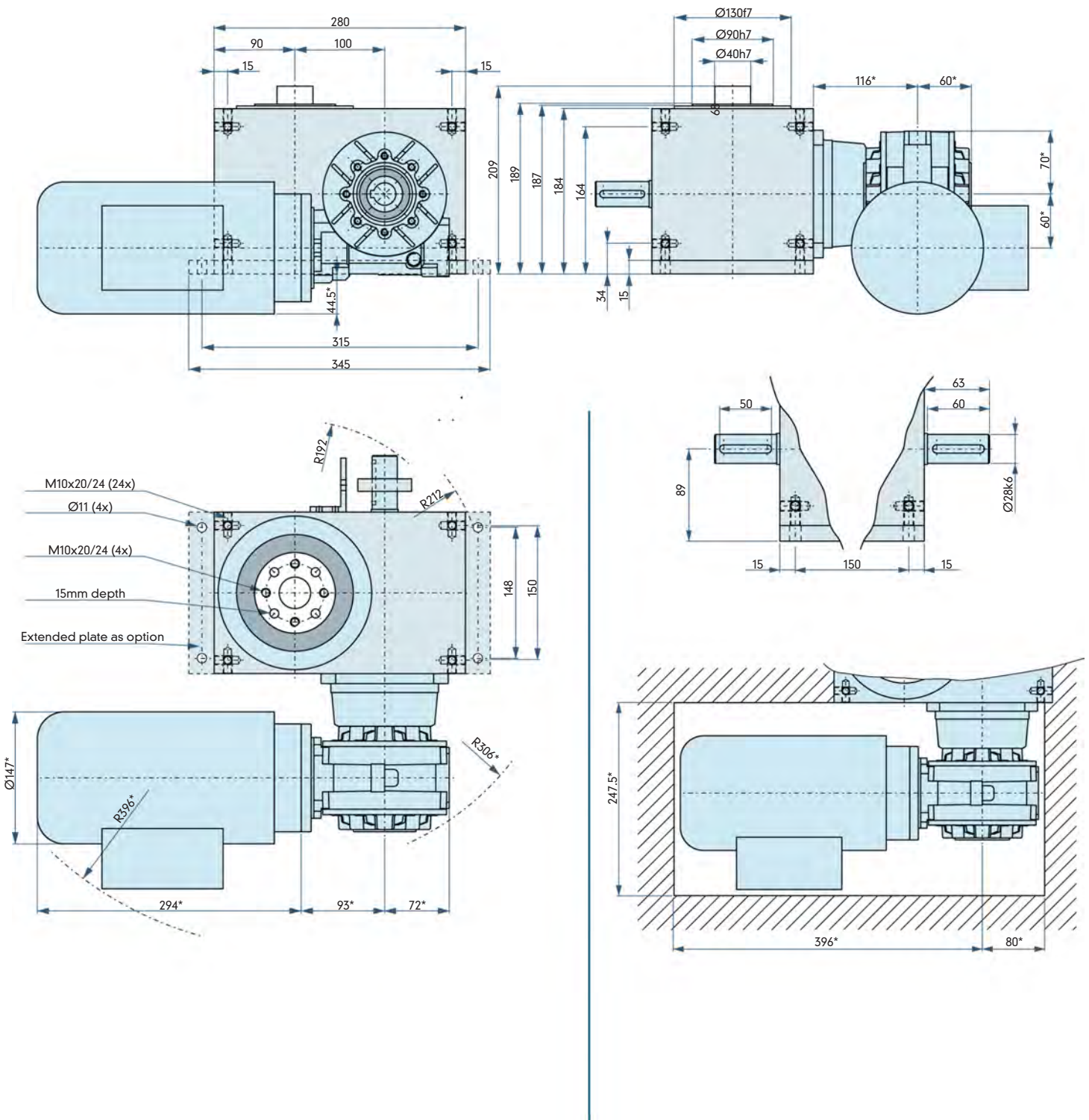

TG100 Dimensions

The measurements shown here illustrate the standard unit. We will gladly customize the housing, shaft(s) and/or output flange to suit your needs. The drive shaft as well as the output shaft (if applicable) are available as double sided shafts with and without keyways. If you would like to add additional holes into the housing, please contact us for possible drilling depths.



The dimensions for the gearmotor may change based on the gearmotor size and options required for the application.

TG100 Load Table

Angle on Output Shaft [°]	Number of Stops n	Index Angle [°]	Acceleration Form MS	Indexer Torque M_{AB} [Nm]			Moment of Inertia J [kgm ²]			Mechanical Index Time t_s [S]		
				n=50	n=100	n=200	n=50	n=100	n=200	n=50	n=100	n=200
360°	1	330	MS30	52	43	36	1	0.2	0.04	1.1	0.55	0.28
		300	MS50	48	39	30	1	0.2	0.04	1	0.5	0.25
180°	2	270	MS0	58	51	43	1.9	0.4	0.09	0.9	0.45	0.23
		210	MS30	48	46	41	1.1	0.3	0.06	0.7	0.35	0.18
		150	MS50	42	40	39	0.3	0.1	0.02	0.5	0.25	0.13
120°	3	270	MS0	74	68	59	4.1	1	0.21	0.9	0.45	0.23
		210	MS30	73	67	57	2.1	0.5	0.1	0.7	0.35	0.18
		150	MS30	61	53	46	0.9	0.2	0.04	0.5	0.25	0.13
		120	MS30	60	52	43	0.6	0.1	0.03	0.4	0.2	0.1
90°	4	270	MS0	68	61	53	5.1	1.1	0.25	0.9	0.45	0.23
		210	MS0	66	59	51	3	0.7	0.14	0.7	0.35	0.18
		150	MS30	64	57	49	1.3	0.3	0.06	0.5	0.25	0.13
		90	MS30	64	57	49	0.5	0.1	0.02	0.3	0.15	0.08
72°	5	270	MS0	68	61	53	6.3	1.4	0.31	0.9	0.45	0.23
		210	MS0	66	59	51	3.7	0.8	0.18	0.7	0.35	0.18
		150	MS30	64	57	49	1.6	0.4	0.08	0.5	0.25	0.13
		90	MS30	64	57	49	0.6	0.1	0.03	0.3	0.15	0.08
60°	6 ¹	270	MS0	86	71	56	9.6	2	0.39	0.9	0.45	0.23
		240	MS0	83	69	54	7.3	1.5	0.3	0.8	0.4	0.2
		180	MS30	79	65	51	3.4	0.7	0.14	0.6	0.3	0.15
		120	MS30	75	61	46	1.4	0.3	0.05	0.4	0.2	0.1
45°	8 ¹	270	MS0	86	71	56	12.8	2.6	0.52	0.9	0.45	0.23
		240	MS0	83	69	54	9.8	2	0.4	0.8	0.4	0.2
		180	MS30	79	65	51	4.5	0.9	0.18	0.6	0.3	0.15
		120	MS30	75	61	46	1.9	0.4	0.07	0.4	0.2	0.1
36°	10 ¹	270	MS0	86	71	56	16	3.3	0.65	0.9	0.45	0.23
		240	MS0	83	69	54	12.2	2.5	0.5	0.8	0.4	0.2
		180	MS30	79	65	51	5.7	1.2	0.23	0.6	0.3	0.15
		120	MS30	75	61	46	2.4	0.5	0.09	0.4	0.2	0.1
30°	12 ²	240	MS0	62	51	39	11	2.3	0.43	0.8	0.4	0.2

¹) Right angle drives with stop numbers 6, 8 and 10 are designed as a double index, i.e. with each full rotation of the drive shaft, two indexes occur in the output.

²) Right angle drives with 12 stops are designed as a four step index, i.e. with each full rotation of the drive shaft, four indexes occur in the output.

³) The additional load occurring with chains and belts due to friction is not taken into consideration here and must be calculated separately.

Main Dimensions

Shaft distance [mm]	65
Weight without drive [kg]	80
Switching angle [°]	see Load Table
(other switching angles upon request)	
Number of stops	1,2,3,4,5,6,8,10,12
(other numbers of stops upon request)	
Rotating direction	right, left, oscillating
Mounting position	ANY

Capacities

Max. Output torque	See Load Table
Input Shaft	
Load rating dynamic [kN]	11.9
Load rating static [kN]	6.55
Output Shaft	
Load rating dynamic [kN]	11.9

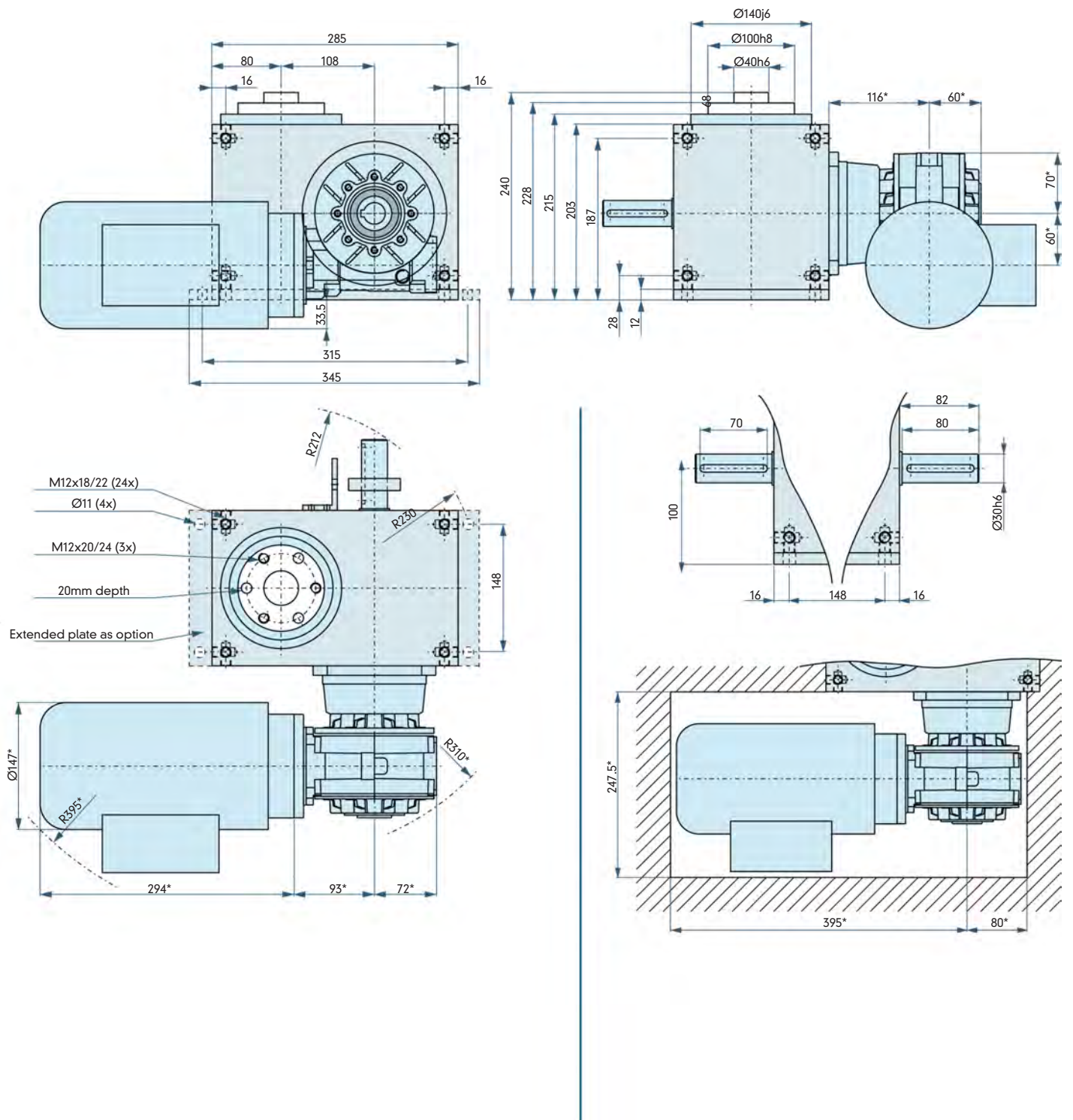

TG108 Dimensions

The measurements shown here illustrate the standard unit. We will gladly customize the housing, shaft(s) and/or output flange to suit your needs. The drive shaft as well as the output shaft (if applicable) are available as double sided shafts with and without keyways. If you would like to add additional holes into the housing yourself, please contact us for possible drilling depths.



The dimensions for the gearmotor may change based on the gearmotor size and options required for the application.

TG108 Load Table

Angle on Output Shaft [°]	Number of Stops n	Index Angle [°]	Acceleration Form MS	Indexer Torque M_{AB} [Nm]			Moment of Inertia J [kgm ²]			Mechanical Index Time t_s [S]		
				n=50	n=100	n=200	n=50	n=100	n=200	n=50	n=100	n=200
360°	1	330	MS30	124	102	81	2.4	0.5	0.1	1.1	0.55	0.28
		300	MS50	123	101	79	2.4	0.5	0.1	1	0.5	0.25
180°	2	270	MS0	132	107	93	4.2	0.9	0.19	0.9	0.45	0.23
		210	MS30	131	107	93	3	0.6	0.13	0.7	0.35	0.18
		150	MS50	103	96	89	0.8	0.2	0.04	0.5	0.25	0.13
120°	3	270	MS0	159	137	112	8.9	1.9	0.39	0.9	0.45	0.23
		210	MS30	152	129	101	4.4	0.9	0.18	0.7	0.35	0.18
		150	MS30	127	103	83	1.9	0.4	0.08	0.5	0.25	0.13
		120	MS30	119	97	78	1.1	0.2	0.05	0.4	0.2	0.1
90°	4	270	MS0	157	132	109	11.7	2.5	0.51	0.9	0.45	0.23
		210	MS0	151	126	96	6.8	1.4	0.27	0.7	0.35	0.18
		150	MS30	138	112	88	2.7	0.6	0.11	0.5	0.25	0.13
		90	MS30	118	92	76	0.8	0.2	0.03	0.3	0.15	0.08
72°	5	270	MS0	157	132	109	14.6	3.1	0.64	0.9	0.45	0.23
		210	MS0	151	126	96	8.5	1.8	0.34	0.7	0.35	0.18
		150	MS30	138	112	88	3.4	0.7	0.14	0.5	0.25	0.13
		90	MS30	118	92	76	1.1	0.2	0.04	0.3	0.15	0.08
60°	6 ¹	270	MS0	186	149	124	20.8	4.2	0.87	0.9	0.45	0.23
		240	MS0	174	146	120	15.4	3.2	0.66	0.8	0.4	0.2
		180	MS30	160	122	96	6.9	1.3	0.26	0.6	0.3	0.15
		120	MS30	132	105	81	2.5	0.5	0.1	0.4	0.2	0.1
45°	8 ¹	270	MS0	186	149	124	27.8	5.6	1.16	0.9	0.45	0.23
		240	MS0	174	146	120	20.5	4.3	0.88	0.8	0.4	0.2
		180	MS30	160	122	96	9.2	1.7	0.34	0.6	0.3	0.15
		120	MS30	132	105	81	3.4	0.7	0.13	0.4	0.2	0.1
36°	10 ¹	270	MS0	186	149	124	34.7	7	1.45	0.9	0.45	0.23
		240	MS0	174	146	120	25.7	5.4	1.11	0.8	0.4	0.2
		180	MS30	160	122	96	11.4	2.2	0.43	0.6	0.3	0.15
		120	MS30	132	105	81	4.2	0.8	0.16	0.4	0.2	0.1
30°	12 ²	240	MS0	110	95	76	19.5	4.2	0.84	0.8	0.4	0.2

¹) Right angle drives with stop numbers 6, 8 and 10 are designed as a double index, i.e. with each full rotation of the drive shaft, two indexes occur in the output.

²) Right angle drives with 12 stops are designed as a four step index, i.e. with each full rotation of the drive shaft, four indexes occur in the output.

³) The additional load occurring with chains and belts due to friction is not taken into consideration here and must be calculated separately.

Main Dimensions

Shaft distance [mm]	80
Weight without drive [kg]	120
Switching angle [°]	see Load Table
(other switching angles upon request)	
Number of stops	1,2,3,4,5,6,8,10,12
(other numbers of stops upon request)	
Rotating direction	right, left, oscillating
Mounting position	ANY

Capacities

Max. Output torque	See Load Table
Input Shaft	
Load rating dynamic [kN]	13.8
Load rating static [kN]	8.3
Output Shaft	
Load rating dynamic [kN]	13.8
Load rating static [kN]	8.3



MOTION INDEX DRIVES

PRECISION LINK CONVEYOR LF & LFS Series

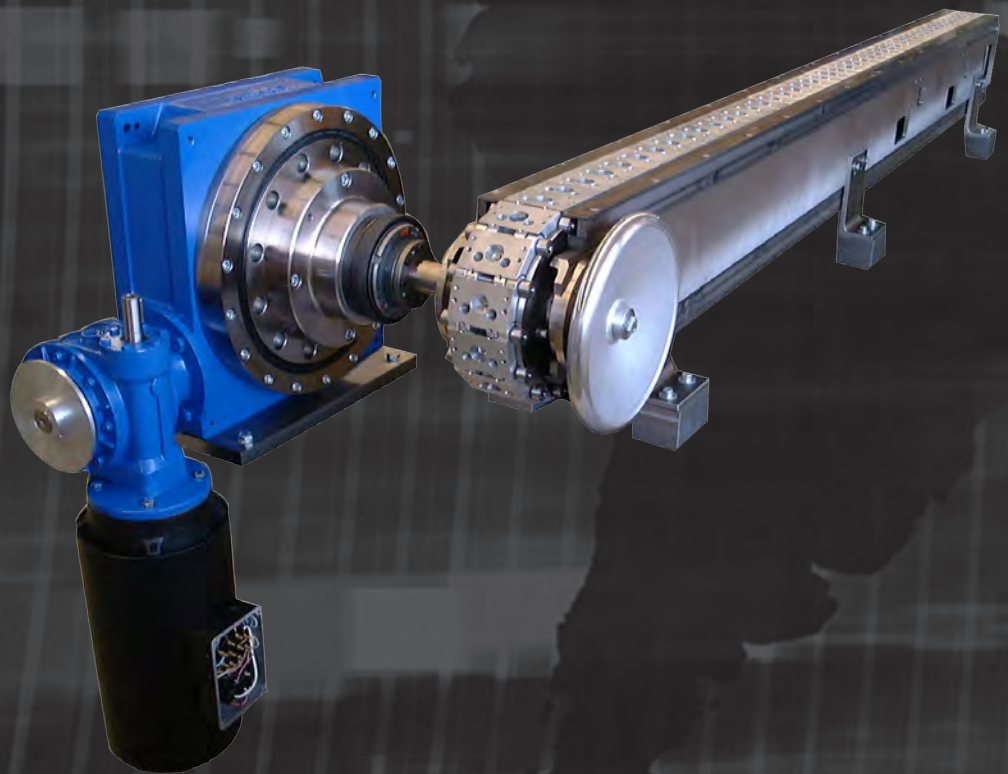



MOTION INDEX DRIVES

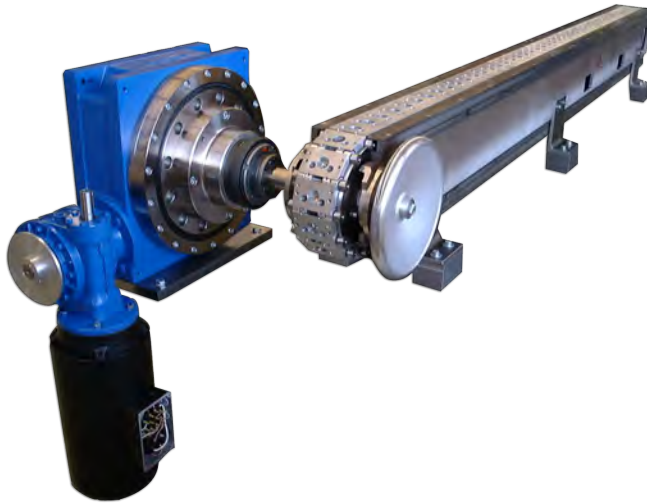

Precision Link Conveyor LF

The main component is a continuous chain manufactured from highly precise aluminum links. There are four cam followers per link for guidance and the guide rails are hardened and fine-milled. The links are connected utilizing shafts and bearings.

The main frame is made from extruded aluminum and steel plates. The conveyor can be mounted to the extruded aluminum or the steel plates. Additional external stations and /or accessories can also easily be mounted to this aluminum extrusion.

The chain is driven by a hardened cam wheel which is driven by a standard indexer or any other custom specified drive. At the other end, a hardened cam guides the chain. This cam is preloaded and has take up adjustment to ensure there is no backlash at the links. The linear stroke of the chain depends on the diameter of the cam wheel. One cycle of the indexer can equal many different combinations of stroke lengths.

Advantages for design engineers and special machine builder

- Proven reliability through many years of service.
- Vertical assembly minimizes footprint. The empty carriers travel through the bottom of the machine.
- Horizontal assembly - in an oval formation. Both sides of the machine can be used for assembly.
- The alternative drive shaft of the indexer can be used for a synchronously rotating parallel shaft to drive the other units.
- The aluminum profile system can be used to mount other external stations fast and easily.

Allowance for individual customer requirements

- Custom drives available.
- Optional overload protection.
- Dwell and index angle can be customized in a large range.
- Non-standard links and linear strokes are possible.
- Chain can be designed in metric or imperial units.
- Customized colors at no additional cost.
- Stainless steel, nickel plating or other special surfaces are available.

Technical benefits for users

- High reliability and long lifetime.
- Robust method of construction.
- Proven to last many years.
- Bearings rolling in oil bath or on clean, dry, hard surfaces.
- Low maintenance (only once a year check and adjust the preloading of the chain).

Main fields

Aerospace, Automotive, Consumer goods, Defense, Electronics, Solar and Wind Energy, Manufacturing, Medical, Packaging.

- Fast assembly of small parts up to 150 per minute.
- Transportation and manufacturing of wires or similar parts
- Mechanical and optical investigation.
- Welding, Tumbling, Riveting, Bending, Marking, Etc.



MOTION INDEX DRIVES

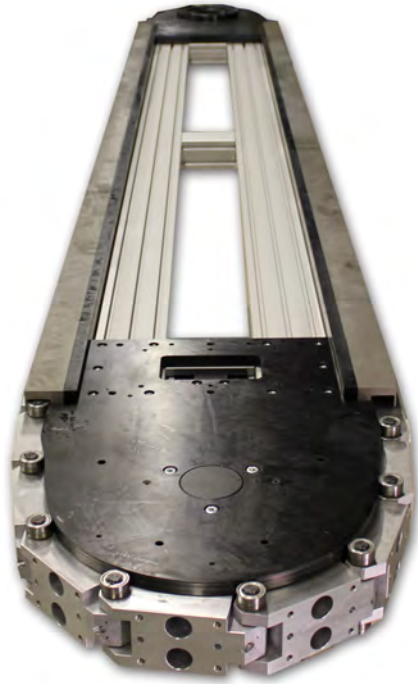

Precision Link Conveyor LFS

The main component is a continuous chain manufactured from highly precise aluminum links. There are four cam followers per link for guidance and the guide rails are hardened and fine-milled. The links are connected utilizing shafts and bearings.

The main frame is made from extruded aluminum and steel plates. The conveyor can be mounted to the extruded aluminum or the steel plates. Additional external stations and/or accessories can also easily be mounted to this aluminum extrusion.

The chain is driven by a hardened cam wheel which is driven by a standard indexer or any other custom specified drive. At the other end, a hardened cam guides the chain. This cam is preloaded and has take up adjustment to ensure there is no backlash at the links. The linear stroke of the chain depends on the diameter of the cam wheel. One cycle of the indexer can equal many different combinations of stroke lengths.

The LFS is a customized form of the proven and reliable LF conveyor that allows for 100% flexibility for positioning. The LFS conveyor uses a customized design drive and take up end, with a specialized cam to allow for infinite positioning utilizing the standard LF links, including all standard and custom sizes. This allows the stroke to be programmed by the customer to be as required for the process. If $\frac{1}{2}$ of a link stroke is required one day, and $\frac{3}{4}$ of a link stroke is required the next day, the LFS conveyor is the answer.

Advantages for design engineers and special machine builder

- Proven reliability through many years of service.
- Vertical assembly minimizes footprint. The empty carriers travel through the bottom of the machine.
- Horizontal assembly in an oval formation. Both sides of the machine can be used for assembly.
- The alternative drive shaft of the indexer can be used for a synchronously rotating parallel shaft to drive the other units.
- The aluminum profile system can be used to mount other external stations fast and easily.
- 100% programmable positioning based on customer programming and requirements.
- No restriction on stroke dimension or stopping location.

Allowance for individual customer requirements

- Custom drives available.
- Optional overload protection.
- Dwell and index angle can be customized in a large range.
- Non-standard links and linear strokes are possible.
- Chain can be designed in metric or imperial units.
- Customized colors at no additional cost.
- Stainless steel, nickel plating or other special surfaces are available.

Technical benefits for users

- High reliability and long lifetime.
- Robust method of construction.
- Proven to last many years.
- Needle or ball bearings rolling in oil bath or on clean, dry, hard surfaces.
- Low maintenance (only once a year check and adjust the preloading of the chain).
- Fully programmable unit can be utilized over and over again for many different applications, simply by retooling the links, and reprogramming the stroke to be what is required. The conveyor stays as an asset with no mechanical rework required.

Main fields

Aerospace, Automotive, Consumer goods, Defense, Electronics, Solar and Wind Energy, Manufacturing, Medical, Packaging.

- Fast assembly of small parts up to 150 per minute.
- Transportation and manufacturing of wires or similar parts
- Mechanical and optical investigation.
- Welding, Tumbling, Riveting, Bending, Marking, Etc.

The shown drive is a RT160 with brake motor and gear reducer

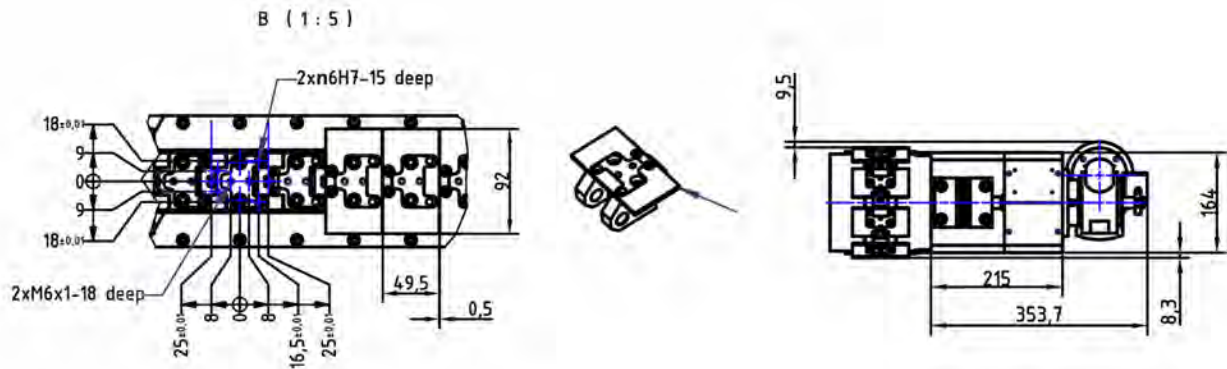
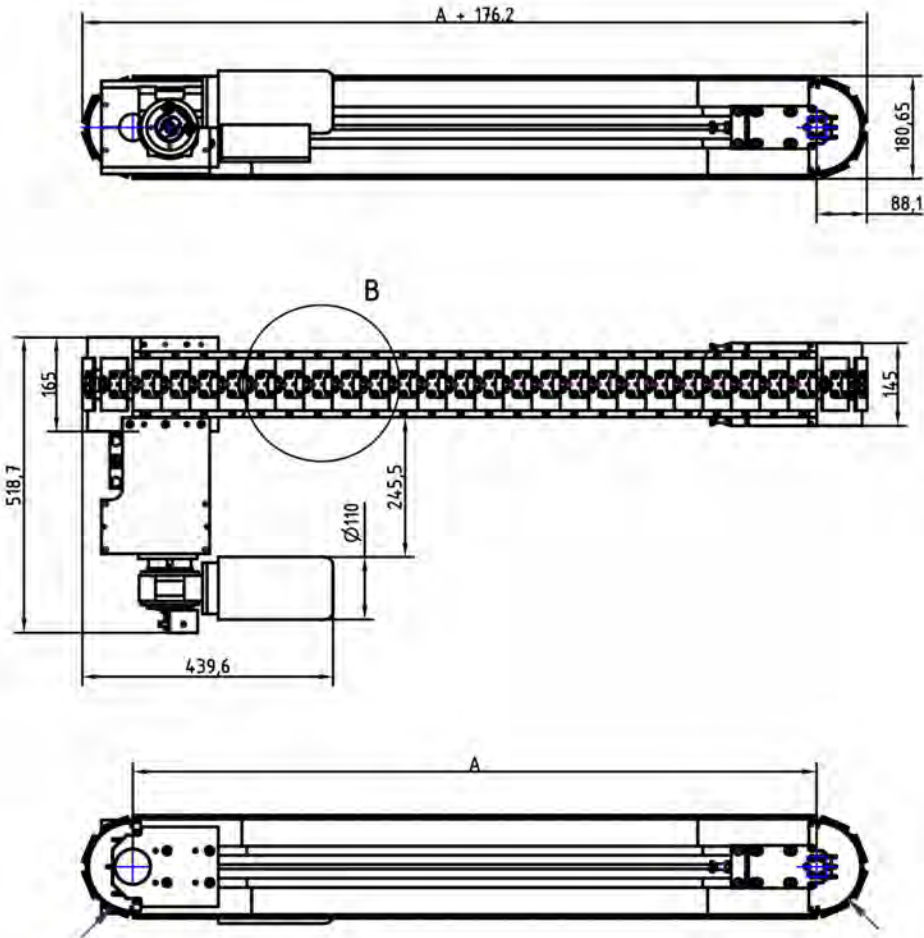



LF050 Dimensions

The dimensions pictured are standard for the LF050 Precision Link Conveyor. Customized applications centered around the LF050 standard size link can be manufactured upon request. Motion LF050 Conveyors can be mounted on the extruded aluminum. The links and the steel plates can be machined to your specifications. The conveyor can be delivered without drive or the drive can be servo. Special dust covers between the links are available.

* LFS Series of this conveyor has slightly different dimensions, please contact MID for more information.

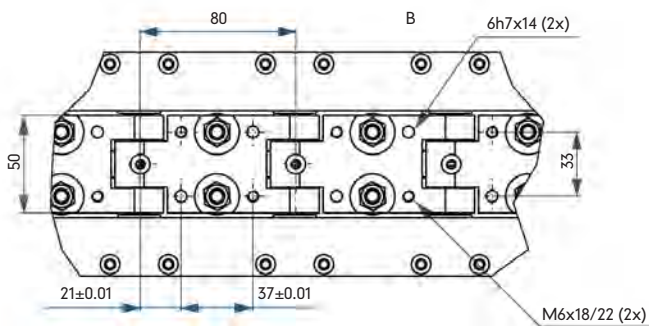
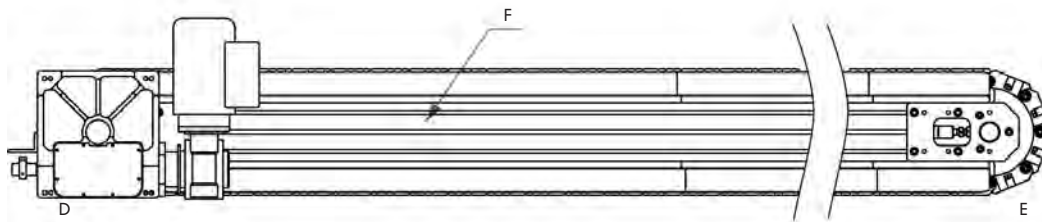
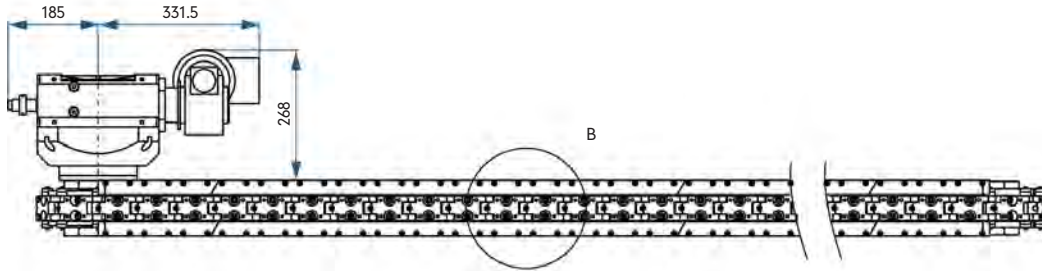
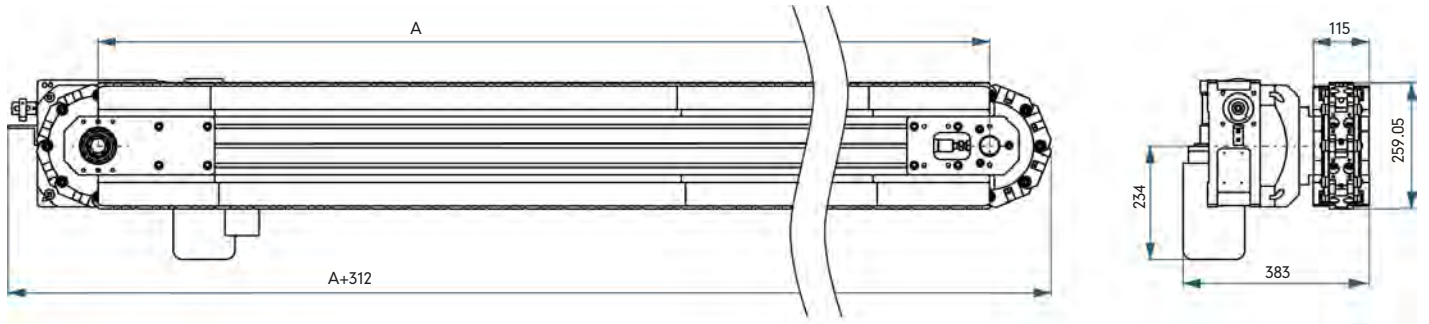
The shown drive is a RT160 with brake motor and gear reducer



 Allow space on one side of the index wheel for adjustable preload.

A = Distance between U-turns

D = Index wheel

E = The 180° cam

F = Aluminum profile system 8*80x120

LF080 Dimensions

The dimensions shown here are the standard dimensions. Dimension "A" depends on the number of links. Motion LF080 Conveyors can be mounted on the extruded aluminum "F". The links and the steel plates can be machined to your specifications. The dimensions marked with * depend on the size of the drive used. The conveyor can be delivered without drive or the drive can be a servo. Special dust covers between the links are available.

* LFS Series of this conveyor has slightly different dimensions, please contact MID for more information.

LF080 Load Table

s [mm]	t [s]	$n_L = 12 ; n_T = 32$ A = 960mm				$n_L = 18 ; n_T = 44$ A = 1440mm				$n_L = 24 ; n_T = 56$ A = 1920mm				$n_L = 30 ; n_T = 68$ A = 2400mm				$n_L = 36 ; n_T = 80$ A = 2880mm			
		m [kg]				m [kg]				m [kg]				m [kg]				m [kg]			
		0.5	1	1.5	2	0.5	1	1.5	2	0.5	1	1.5	2	0.5	1	1.5	2	0.2	1	1.5	2
80 ¹	t=	0.16	0.19	0.22	0.25	0.18	0.22	0.26	0.29	0.21	0.25	0.3	0.23	0.23	0.28	0.33	0.37	0.25	0.3	0.35	0.4
160 ²	t=	0.24	0.29	0.34	0.38	0.28	0.34	0.4	0.45	0.31	0.39	0.45	0.35	0.35	0.43	0.5	0.56	0.38	0.46	0.54	0.61
240 ³	t=	0.32	0.4	0.46	0.52	0.38	0.47	0.54	0.61	0.43	0.53	0.61	0.47	0.47	0.58	0.68	0.76	0.51	0.63	0.74	0.83

s [mm]	t [s]	$n_L = 42 ; n_T = 92$ A = 3360mm				$n_L = 48 ; n_T = 104$ A = 3840mm				$n_L = 54 ; n_T = 116$ A = 4320mm				$n_L = 60 ; n_T = 128$ A = 4800mm				$n_L = 66 ; n_T = 140$ A = 5280mm			
		m [kg]				m [kg]				m [kg]				m [kg]				m [kg]			
		0.5	1	1.5	2	0.5	1	1.5	2	0.5	1	1.5	2	0.5	1	1.5	2	0.2	1	1.5	2
80 ¹	t=	0.27	0.33	0.38	0.43	0.28	0.35	0.41	0.46	0.6	0.37	0.43	0.49	0.31	0.39	0.45	0.51	0.33	0.41	0.48	0.54
160 ²	t=	0.4	0.5	0.58	0.66	0.43	0.53	0.62	0.7	0.45	0.56	0.66	0.74	0.48	0.59	0.69	0.78	0.5	0.62	0.73	0.82
240 ³	t=	0.55	0.68	0.79	0.9	0.59	0.73	0.85	0.96	0.62	0.77	0.9	1.01	0.65	0.81	0.95	1.07	0.68	0.85	0.99	1.12

s = Stroke [mm]
t = Stroke time [s]

n_L = Number of links in line
 n_T = Number of links total

m = Weight per link [kg]
A = Distance between U-Turns

¹ The chain moves one link with each index

² The chain moves two links with each index

³ The chain moves three links with each index

Main Dimensions

Distance A** [mm] in increments of 480
Weight at A=2000 [kg] 300
Stroke time** [s] see Load Table
Stroke** [mm] 80,160 or 240
Direction right, left

** Other distances "A", strokes or stroke times by request

Loadings

Per static link
Force vertical [N]
Force horizontal [N]
Tilting moment [Nm]
Pull force at the chain [N]

Standard Drive

RT160 with 8¹, 4², or 8/3³ Indexes

Precision

In feed direction*
700 at the drive [mm] ±0.04
2600 opposite the drive [mm] ±0.07
80 Transverse to feed direction [mm] ±0.05
750 Vertical runout [mm] ±0.03

* For the first and last link in the line we can not guarantee this precision.

The shown drive is a RT160 with brake motor and gear reducer

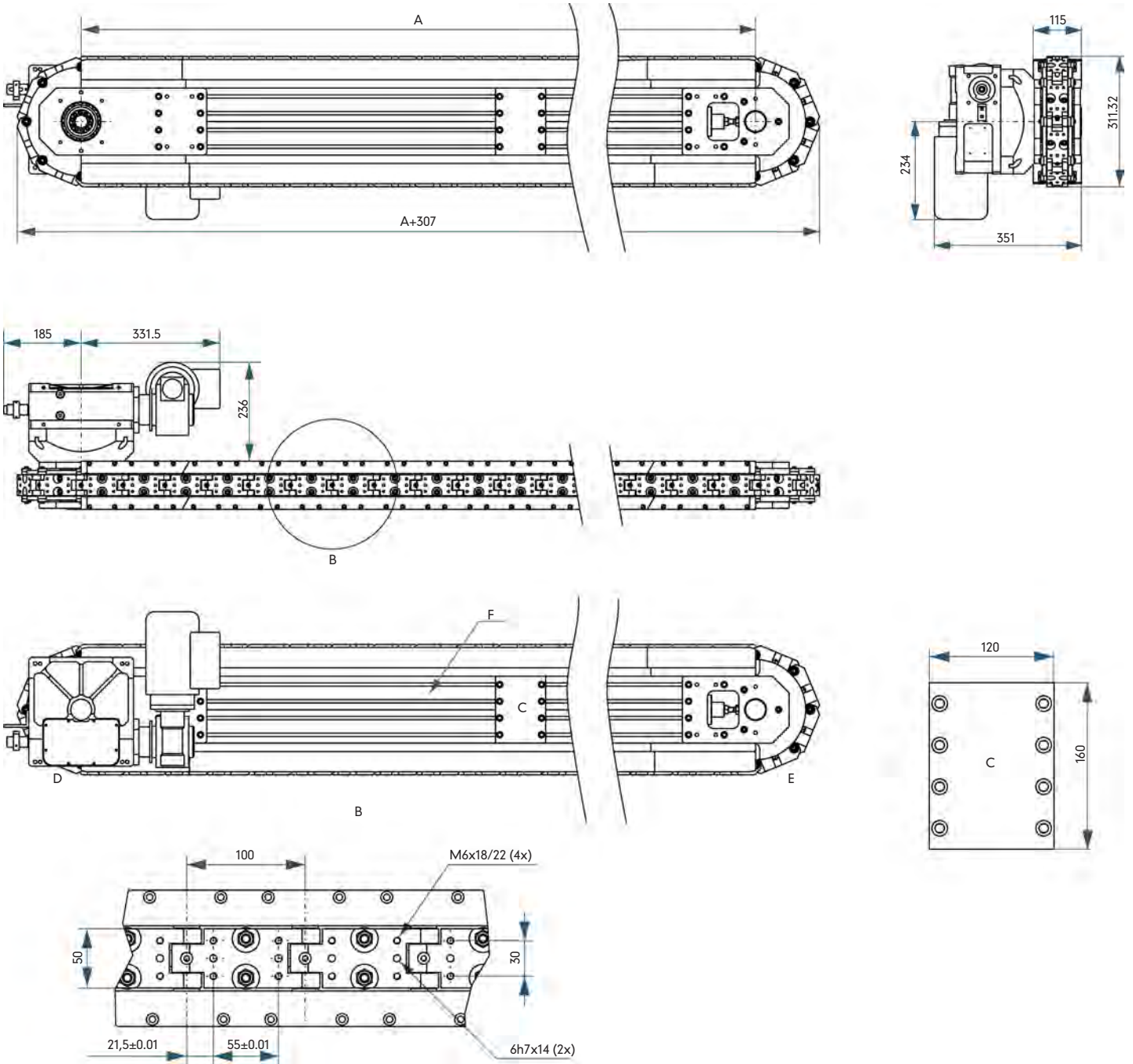

 Allow space on one side of the index wheel for adjustable preload.

A = Distance between U-turns

D = Index wheel

E = The 180° cam

F = Aluminum profile system 8*80x120

LF100 Dimensions

The dimensions shown here are the standard dimensions. Dimension "A" depends on the number of links. Motion LF100 Conveyors can be mounted on the extruded aluminum "F". The links and the steel plates can be machined to your specifications. The dimensions marked with * depend on the size of the drive used. The conveyor can be delivered without drive or the drive can be a servo. Special dust covers between the links are available.

* LFS Series of this conveyor has slightly different dimensions, please contact MID for more information.

LF100 Load Table

s [mm]	t [s]	$n_L = 10 ; n_T = 28$ A = 1000mm				$n_L = 15 ; n_T = 38$ A = 1500mm				$n_L = 20 ; n_T = 48$ A = 2000mm				$n_L = 25 ; n_T = 58$ A = 2500mm				$n_L = 30 ; n_T = 68$ A = 3000mm			
		m [kg]				m [kg]				m [kg]				m [kg]				m [kg]			
		0.5	1	1.5	2	0.5	1	1.5	2	0.5	1	1.5	2	0.5	1	1.5	2	0.2	1	1.5	2
100 ¹	t=	0.16	0.19	0.22	0.24	0.18	0.22	0.26	0.29	0.21	0.25	0.29	0.32	0.23	0.28	0.32	0.36	0.25	0.3	0.34	0.39
200 ²	t=	0.24	0.29	0.33	0.37	0.28	0.34	0.39	0.44	0.31	0.38	0.44	0.49	0.35	0.42	0.48	0.54	0.38	0.46	0.52	0.59
300 ³	t=	0.33	0.4	0.46	0.51	0.38	0.46	0.53	0.6	0.43	0.52	0.6	0.67	0.47	0.57	0.66	0.74	0.51	0.62	0.72	0.8

s [mm]	t [s]	$n_L = 35 ; n_T = 78$ A = 3500mm				$n_L = 40 ; n_T = 88$ A = 4000mm				$n_L = 45 ; n_T = 98$ A = 4500mm				$n_L = 50 ; n_T = 108$ A = 5000mm				$n_L = 55 ; n_T = 118$ A = 5500mm			
		m [kg]				m [kg]				m [kg]				m [kg]				m [kg]			
		0.5	1	1.5	2	0.5	1	1.5	2	0.5	1	1.5	2	0.5	1	1.5	2	0.2	1	1.5	2
100 ¹	t=	0.26	0.32	0.37	0.41	0.28	0.34	0.39	0.44	0.3	0.36	0.42	0.47	0.31	0.38	0.44	0.49	0.33	0.4	0.46	0.52
200 ²	t=	0.4	0.49	0.56	0.63	0.43	0.52	0.6	0.67	0.45	0.55	0.63	0.71	0.47	0.58	0.67	0.75	0.5	0.6	0.7	0.79
300 ³	t=	0.55	0.67	0.77	0.86	0.58	0.71	0.82	0.92	0.62	0.75	0.87	0.97	0.65	0.79	0.91	1.02	0.68	0.83	0.96	1.07

s = Stroke [mm]
t = Stroke time [s]

n_L = Number of links in line
 n_T = Number of links total

m = Weight per link [kg]
A = Distance between U-Turns

¹ The chain moves one link with each index

² The chain moves two links with each index

³ The chain moves three links with each index

Main Dimensions

Distance A** [mm] in increments of 500
Weight at A=2000 [kg] 350
Stroke time** [s] see Load Table
Stroke** [mm] 100,200 or 300
Direction right, left

** Other distances "A", strokes or stroke times by request

Loadings

Per static link
Force vertical [N]
Force horizontal [N]
Tilting moment [Nm]
Pull force at the chain [N]

Standard Drive

RT160 with 8¹, 4², or 8/3³ Indexes

Precision

In feed direction*
700 at the drive [mm] ±0.04
2600 opposite the drive [mm] ±0.07
80 Transverse to feed direction [mm] ±0.05
750 Vertical runout [mm] ±0.03

* For the first and last link in the line we can not guarantee this precision.

The shown drive is a RT160 with brake motor and gear reducer

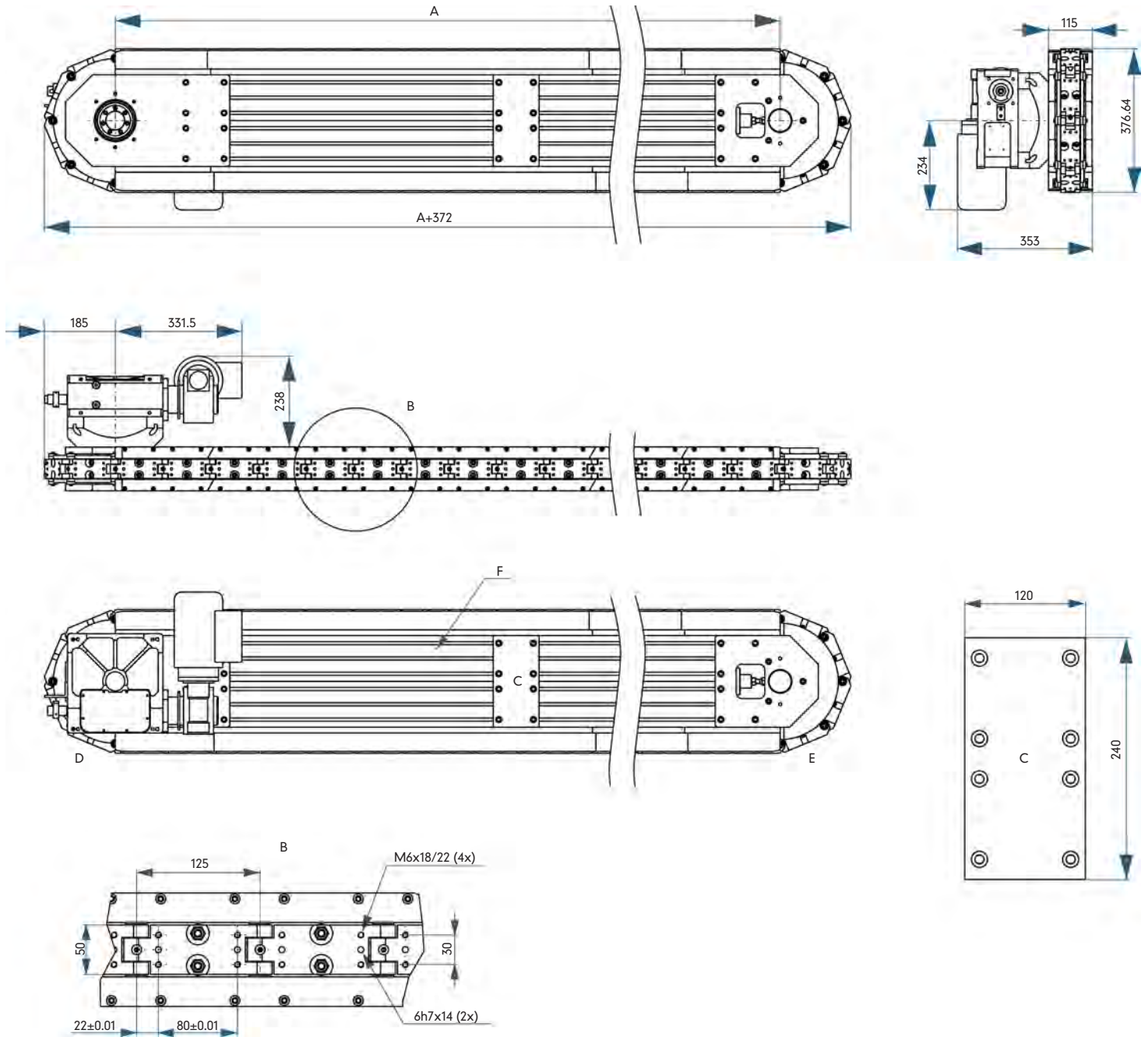

 Allow space on one side of the index wheel for adjustable preload.

A = Distance between U-turns

D = Index wheel

E = The 180° cam

F = Aluminum profile system 8*80x120

LF125 Dimensions

The dimensions shown here are the standard dimensions. Dimension "A" depends on the number of links. Motion LF125 Conveyors can be mounted on the extruded aluminum "F". The links and the steel plates can be machined to your specifications. The dimensions marked with * depend on the size of the drive used. The conveyor can be delivered without drive or the drive can be a servo. Special dust covers between the links are available.

* LFS Series of this conveyor has slightly different dimensions, please contact MID for more information.

LF125 Load Table

s [mm]	t [s]	$n_L = 8 ; n_T = 24$ A = 1000mm				$n_L = 12 ; n_T = 32$ A = 1500mm				$n_L = 16 ; n_T = 40$ A = 2000mm				$n_L = 20 ; n_T = 48$ A = 2500mm				$n_L = 24 ; n_T = 56$ A = 3000mm			
		m [kg]				m [kg]				m [kg]				m [kg]				m [kg]			
		0.5	1	1.5	2	0.5	1	1.5	2	0.5	1	1.5	2	0.5	1	1.5	2	0.2	1	1.5	2
125 ¹	t=	0.17	0.2	0.23	0.25	0.19	0.23	0.26	0.29	0.22	0.26	0.29	0.32	0.24	0.28	0.32	0.36	0.26	0.3	0.35	0.39
250 ²	t=	0.25	0.3	0.34	0.38	0.29	0.35	0.4	0.44	0.33	0.39	0.45	0.49	0.36	0.43	0.49	0.54	0.39	0.46	0.53	0.59
375 ³	t=	0.35	0.41	0.47	0.52	0.40	0.48	0.54	0.6	0.45	0.53	0.61	0.68	0.49	0.59	0.67	0.74	0.53	0.63	0.72	0.8

s [mm]	t [s]	$n_L = 28 ; n_T = 64$ A = 3500mm				$n_L = 32 ; n_T = 72$ A = 4000mm				$n_L = 36 ; n_T = 80$ A = 4500mm				$n_L = 40 ; n_T = 88$ A = 5000mm				$n_L = 44 ; n_T = 96$ A = 5500mm			
		m [kg]				m [kg]				m [kg]				m [kg]				m [kg]			
		0.5	1	1.5	2	0.5	1	1.5	2	0.5	1	1.5	2	0.5	1	1.5	2	0.2	1	1.5	2
125 ¹	t=	0.27	0.33	0.37	0.41	0.29	0.35	0.4	0.44	0.31	0.37	0.42	0.46	0.32	0.38	0.44	0.49	0.34	0.4	0.46	0.51
250 ²	t=	0.42	0.5	0.57	0.63	0.44	0.53	0.6	0.67	0.47	0.56	0.64	0.71	0.49	0.58	0.67	0.74	0.51	0.61	0.7	0.78
375 ³	t=	0.57	0.68	0.77	0.86	0.6	0.72	0.82	0.92	0.64	0.76	0.87	0.97	0.67	0.8	0.91	1.02	0.7	0.83	0.95	1.06

s = Stroke [mm]
t = Stroke time [s]

n_L = Number of links in line
 n_T = Number of links total

m = Weight per link [kg]
A = Distance between U-Turns

¹ The chain moves one link with each index

² The chain moves two links with each index

³ The chain moves three links with each index

Main Dimensions

Distance A** [mm] in increments of 500
Weight at A=2000 [kg] 400
Stroke time** [s] see Load Table
Stroke** [mm] 125, 250 or 375
Direction right, left

** Other distances "A", strokes or stroke times by request

Loadings

Per static link
Force vertical [N]
Force horizontal [N]
Tilting moment [Nm]
Pull force at the chain [N]

Standard Drive

RT160 with 8¹, 4², or 8/3³ Indexes

Precision

In feed direction*
700 at the drive [mm] ±0.04
2600 opposite the drive [mm] ±0.07
80 Transverse to feed direction [mm] ±0.05
750 Vertical runout [mm] ±0.03

* For the first and last link in the line we can not guarantee this precision.

The shown drive is a RT250 with brake motor and gear reducer

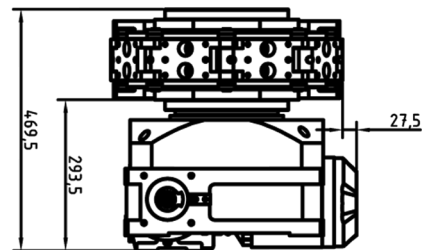
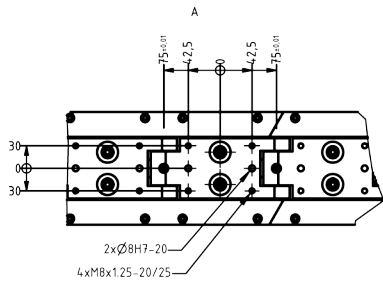
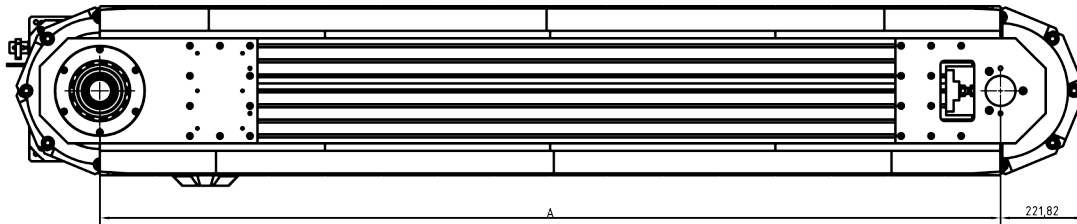
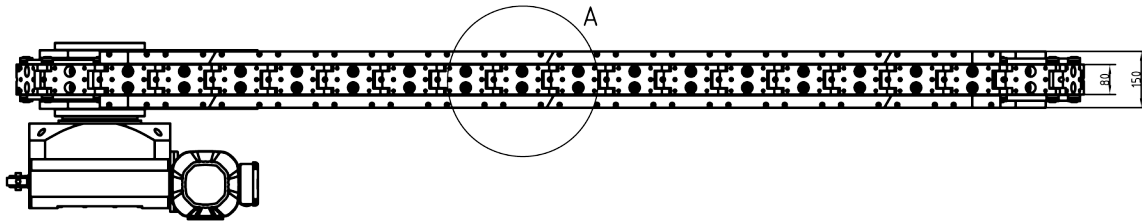
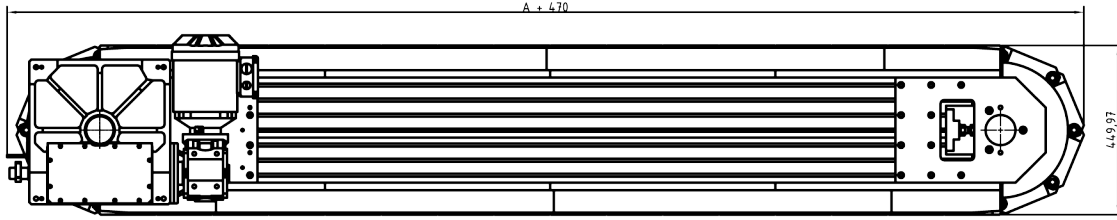

 Allow space on one side of the index wheel for adjustable preload.

A = Distance between U-turns

D = Index wheel

E = The 180° cam

F = Aluminum profile system 8*80x120

LF150 Dimensions

The dimensions shown here are the standard dimensions. Dimension "A" depends on the number of links. Motion LF150 Conveyors can be mounted on the extruded aluminum. The links and the steel plates can be machined to your specifications. The dimensions marked with * depend on the size of the drive used. The conveyor can be delivered without drive or the drive can be a servo. Special dust covers between the links are available.

* LFS Series of this conveyor has slightly different dimensions, please contact MID for more information.

LF150 Load Table

s [mm]	t [s]	$n_L = 8 ; n_T = 28$ A = 1200mm				$n_L = 12 ; n_T = 36$ A = 1800mm				$n_L = 16 ; n_T = 44$ A = 2400mm				$n_L = 20 ; n_T = 52$ A = 3000mm				$n_L = 24 ; n_T = 60$ A = 3600mm			
		m [kg]				m [kg]				m [kg]				m [kg]				m [kg]			
		0.5	1	1.5	2	0.5	1	1.5	2	0.5	1	1.5	2	0.5	1	1.5	2	0.2	1	1.5	2
150 ¹	t=	0.28	0.3	0.32	0.34	0.3	0.33	0.35	0.38	0.32	0.35	0.38	0.41	0.34	0.37	0.4	0.44	0.35	0.39	0.43	0.46
300 ²	t=	0.39	0.42	0.46	0.48	0.42	0.46	0.5	0.53	0.45	0.49	0.54	0.57	0.48	0.53	0.57	0.62	0.5	0.56	0.61	0.65
450 ³	t=	0.52	0.56	0.6	0.64	0.56	0.61	0.66	0.7	0.59	0.65	0.71	0.76	0.63	0.69	0.75	0.81	0.66	0.73	0.8	0.86

s [mm]	t [s]	$n_L = 28 ; n_T = 68$ A = 4200mm				$n_L = 32 ; n_T = 76$ A = 4800mm				$n_L = 36 ; n_T = 84$ A = 5400mm				$n_L = 40 ; n_T = 92$ A = 6000mm				$n_L = 44 ; n_T = 100$ A = 6600mm			
		m [kg]				m [kg]				m [kg]				m [kg]				m [kg]			
		0.5	1	1.5	2	0.5	1	1.5	2	0.5	1	1.5	2	0.5	1	1.5	2	0.2	1	1.5	2
150 ¹	t=	0.37	0.41	0.45	0.49	0.39	0.43	0.47	0.51	0.4	0.45	0.5	0.54	0.42	0.47	0.52	0.56	0.43	0.49	0.54	0.58
300 ²	t=	0.52	0.58	0.64	0.69	0.55	0.61	0.67	0.73	0.57	0.64	0.7	0.76	0.59	0.66	0.73	0.79	0.61	0.69	0.76	0.82
450 ³	t=	0.69	0.77	0.84	0.91	0.72	0.81	0.88	0.96	0.75	0.84	0.92	1	0.78	0.87	0.96	1.04	0.81	0.91	1	1.09

s = Stroke [mm]
t = Stroke time [s]

n_L = Number of links in line
 n_T = Number of links total

m = Weight per link [kg]
A = Distance between U-Turns

¹ The chain moves one link with each index

² The chain moves two links with each index

³ The chain moves three links with each index

Main Dimensions

Distance A** [mm] in increments of 600
Weight at A=2000 [kg] 800
Stroke time** [s] see Load Table
Stroke** [mm] 150, 300 or 450
Direction right, left

** Other distances "A", strokes or stroke times by request

Loadings

Per static link
Force vertical [N]
Force horizontal [N]
Tilting moment [Nm]
Pull force at the chain [N]

Standard Drive

RT250 with 8¹, 4², or 8/3³ Indexes

Precision

In feed direction*
at the drive [mm] ±0.04
opposite the drive [mm] ±0.07
Transverse to feed direction [mm] ±0.05
Vertical runout [mm] ±0.03

* For the first and last link in the line we can not guarantee this precision.



MOTION INDEX DRIVES

Timing Belt Conveyor

Motion Index Drives' LZ Series Conveyors are an alternative for those seeking a more cost-effective conveyor system with the same quality Motion Index Drives brings to all of its products. The LZ Series features a high quality guide rail system, as well as a timing belt driven by one of Motion Index Drives' high quality indexers. LZ Series conveyors are custom made utilizing our high precision XP, TP, or RT Series indexers. By using our high precision cam indexing devices for transfer and positioning, you are guaranteed 100% repeatability on each index.

The chain is driven by a hardened cam wheel which is driven by a standard indexer or any other custom specified drive. At the other end, a hardened cam guides the chain. This cam is preloaded and has take up adjustment to ensure there is no backlash at the links. The linear stroke of the chain depends on the diameter of the cam wheel. One cycle of the indexer can equal many different combinations of stroke lengths.

Key Features and Benefits

- Customized to your needs.
- Utilizes high precision cam indexers for positioning.
- Steel frame to mount fixtures and other automated devices.
- Available in freely programmable option.

For technical information, please contact Motion Index Drives and provide some basic application information.





MOTION INDEX DRIVES

PICK AND PLACE UNIT
Multiple Series



Pick and Place Units

Available Courses of Motion

Pick and Place Unit
Drive indexes in one direction

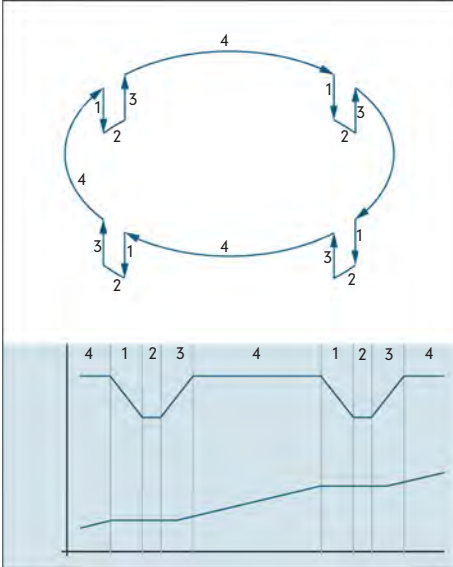

Pick and Place Unit
Drive changes rotating direction at X

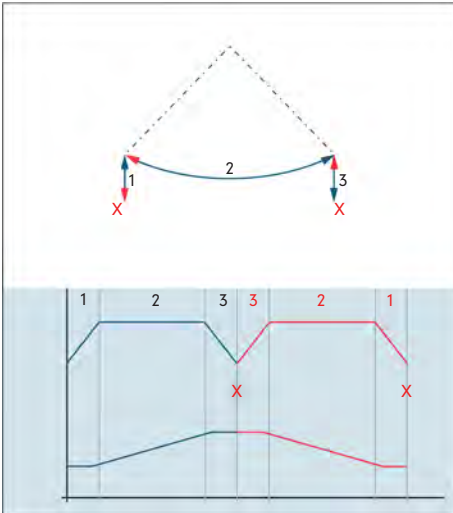

Pendulum Pick and Place Unit
Drive indexes in one direction

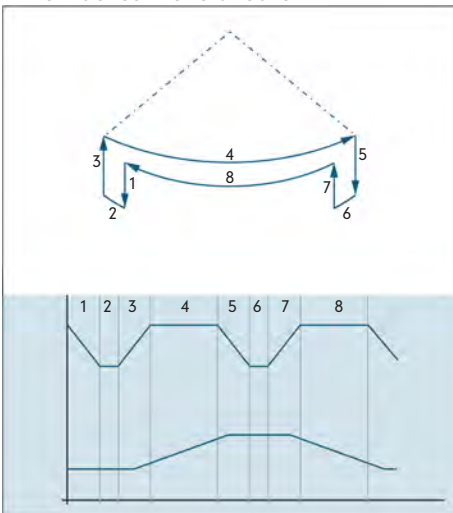

Series GH

- Single drive for pick and place
- Right angle cam for rotation
- Flat cam for lift
- The relationship between lift and rotation can be customized
- Compact, durable unit
- Optional thru-hole

GH 100
Vertical stroke [mm] 55
Rotation 80°
Pendulum 90°



Series RH

- Single drive for pick and place
- Barrel cam for rotation
- Flat cam for lift
- Compact, durable unit
- Optional thru-hole
- Maintenance-free lubrication

RH 100
Vertical stroke [mm] 30
Rotation 90°
Pendulum 60°



Series PH

- Single drive for pick and place
- Barrel cam for lift
- Large torque with use of flat cam
- Flat cam for rotation
- Compact, durable unit
- Optional thru-hole
- Maintenance-free lubrication

PH 065
Vertical stroke [mm] 40
Rotation 180°
Pendulum 90°



RT100 + VT30
Vertical stroke [mm] 30
Rotation 180°
Pendulum 90°*



* larger pendulum angle by changing the rotating direction of the drive

Series RT + VP

- Standard indexer for rotating
- Pneumatic cylinder for lifting
- Pick and placing are independently controlled from each other
- Compact, durable unit
- Optional thru-hole

Pick and Place Units

All units are customized based on the requirements of each application. With the combination options of cylinder, disk cam, disc groove, globoid, pneumatics and servo technology results in a large variety of pick and place solutions.

RT100 + VP300
 Vertical stroke [mm] 300
 Rotation 180°
 Pendulum 90°*

*Larger pendulum angle by changing the rotating direction of the drive



Series RT + VP

- Standard indexer for rotating
- Pneumatic cylinder for lifting
- Lifting and rotating are independently controlled from each other
- Compact, durable unit
- Optional thru-hole

HDM 30
 Vertical stroke [mm] 55
 Rotation free



Series HDM

- Two different servo drives for lift and rotate
- Vertical stroke and rotating angle are fully programmable
- Customized servo drives are optional
- Course of motion controlled by servo
- Maintenance-free lubrication
- Optional thru-hole

Linear - Units

Available course of motion

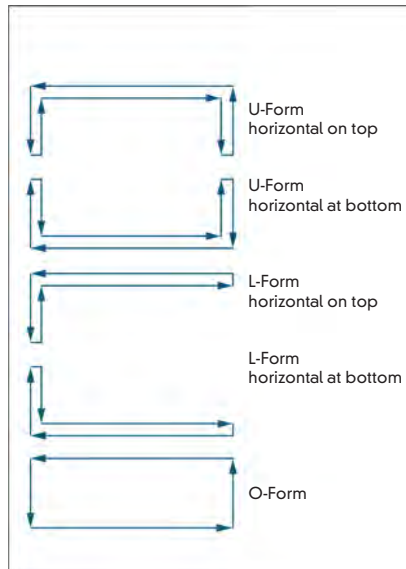

AL 80
 Vertical stroke [mm] 35
 Horizontal stroke [mm] 80

Series AL

- Common drive for lift and rotation
- Flat cam for rotation
- Flat cam for lift
- Vertical stroke protected by a spring
- Compact, durable unit
- Many available courses of motion
- Multiple units can be connected using a common shaft

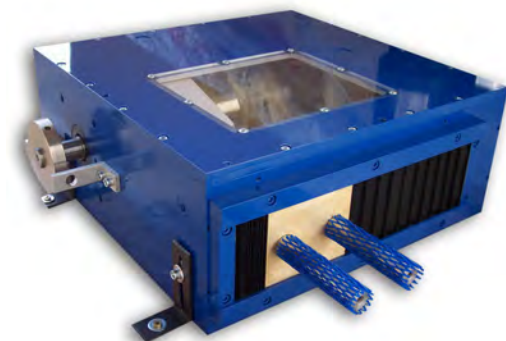



MOTION INDEX DRIVES

Lift and Carry Systems

Motion Index Drives, Inc. is a leading provider of heavy-duty Lift and Carry Machines. Our Lift and Carry Systems operate with minimal motor power and are capable of lifting and transferring an average of 10 complete underbody structures (2,000 lbs. each) over an average linear distance of 19 feet at once. From transferring full length truck frames to engine box and underbody lines, Motion Index Drives has a high-precision engineered solution for your application

Lift and Carry transfer systems are designed to transfer large products down a linear path, usually through various positions for production. Since the products need to be lifted over obstacles or a system by which they could be transferred via the ground would interfere with production, Lift and Carry Systems can be found in the majority of assembly lines working on large items.

Motion Index Drives' Lift and Carry Systems have been placed in a large number of North America's automotive production facilities. These applications are among the most demanding in the world, proving a testament to the strength and reliability of Motion Index Drives quality. This is also, however, the only existing industry-wide application of Lift and Carry Systems.

Lift and Carry Systems can be applied to high-production facilities that manufacture products large in physical dimensions. Motion Index Drives has worked to integrate Lift and Carry Systems in industries including defense manufacturing and off-highway heavy machinery, but current industry systems aren't configured in a fashion that can easily accept a Lift and Carry System.

Smaller scale, lightweight systems can be handled by products such as our AL series Walking Beam.

Key Features and Benefits

- Smooth lift and lowering motion
- Hydraulic compensation system to assist on lift strokes
- Special tooling inserts with customer specified hole patterns
- High-quality extruded steel rails available in many sizes
- Hardened gear rack and pinions for transfers
- Pevolan and Vulkollan transfer rollers for noise reduction and increased life of shuttle rails
- Many different standard and custom lift and transfer shuttle options available

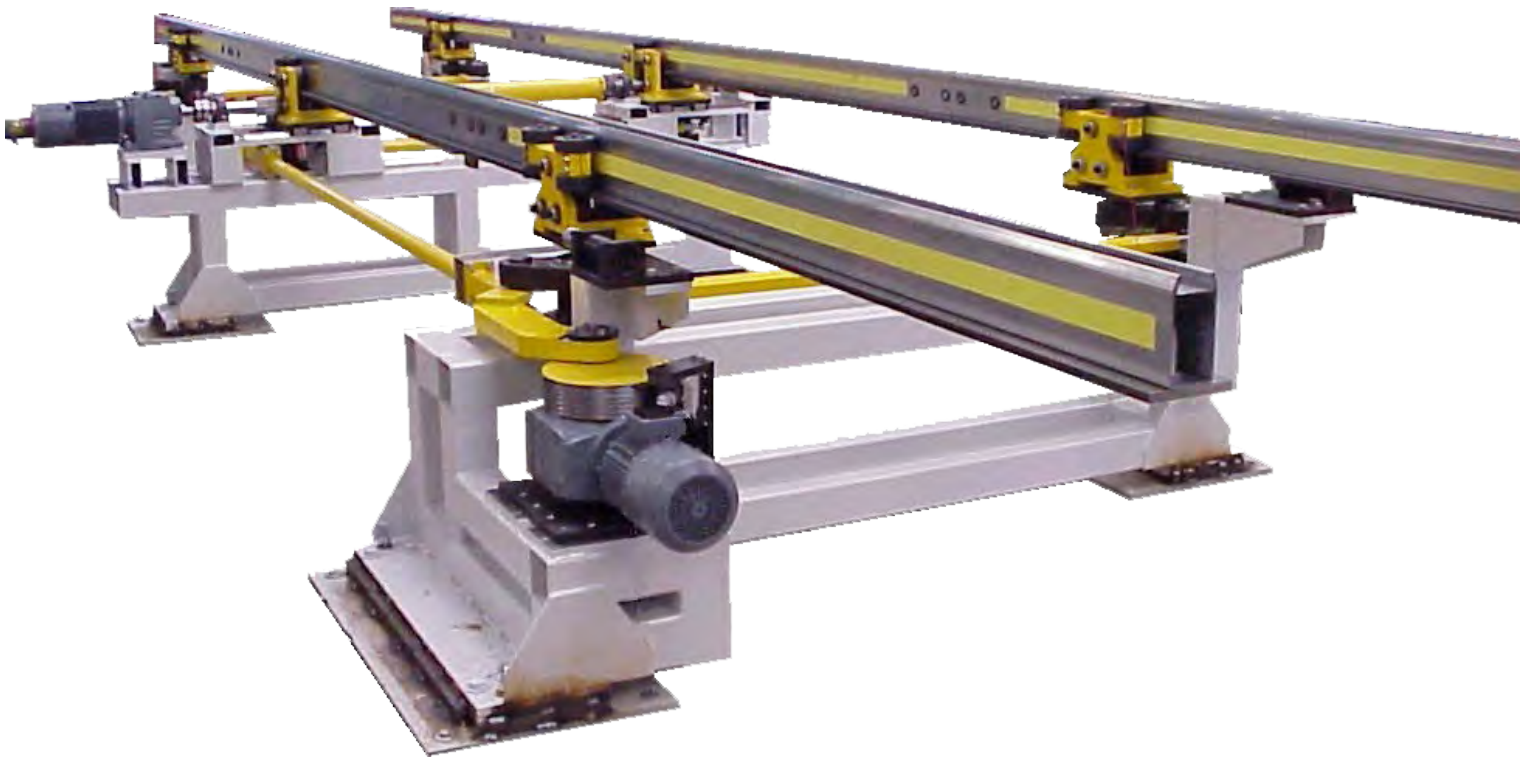



MOTION INDEX DRIVES

Flexible Positioning System
TR Series

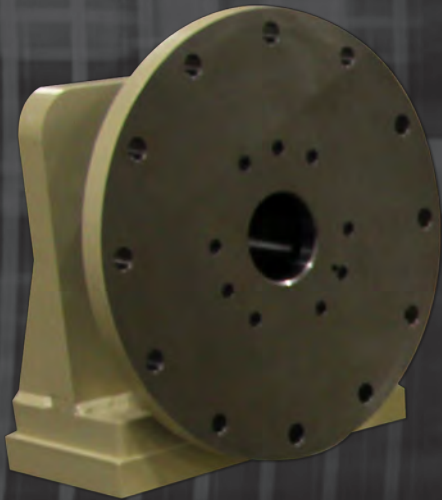



MOTION INDEX DRIVES

An alternative to the extremely high precision and zero backlash TMF and RT series trunnion indexing systems, the TR Series offers a lower cost alternative to applications that require such high standards. Offered in complete head and tail stock standard sets, you have the option to purchase a complete trunnion solution from Motion Index Drives that includes heavy duty constructed base frame, HS/TS riser bases, and fixture backbones.

The TR series is ideal for rollover applications in the aerospace, automotive, defense, construction and mining equipment, alternative energy and railroad transportation manufacturing environments. The TR Series was manufactured to be suited for laser, spot, mig and tig welding applications.

Incorporating the TR series into to your weld cells can be relatively easy by indicating what robot manufacturer you are implementing and the TR Trunnion can be adapted to accept virtually every robot brand.

TR Series

Motion Index Drives' TR series headstock / tailstock trunnion sets utilize a high precision (less than 1 arc minute) planetary gear system mounted in a vertical position complete with mounting plates. TR series Trunnion Index Drives are ideal for moving large masses with smaller units and minimizing your equipment's footprint on the floor. All TR series trunnion units can be ordered with standard or custom frames fully equipped with head and tailstock supports and one-piece base weldments.

Technical benefits for end users

- Long service lives.
- Large thru hole on tailstock for running utilities to fixtures.
- Requires less power than leading competitors.
- Oversized bearings on tailstock for support.
- Directly mount to gear head system mounting plate which eliminates the need for additional pillow blocks.

Options Available

- Special hole patterns in mounting plates on headstock and tailstock.
- Clockwise, counter-clockwise and oscillating index modes of operation.
- Can be ordered as complete assembly with headstock, tailstock and base frame.
- Various gear ratios.
- Variety of encoder or positioning devices.



MOTION INDEX DRIVES TRUNNIONS (All dimensions in mm)					
Assembly Number	Headstock	Tailstock	Ratio	Fanuc Motor	Kuka Motor
TRxxx-xxx-xxxxx	250	250	171	Alpha IF08/3000	MG180
TRxxx-xxx-xxxxx	250	250	171	Alpha IS08/4000	MG110
TRxxx-xxx-xxxxx	300	300	185	Alpha IF12/3000	MG180
TRxxx-xxx-xxxxx	300	300	185	Alpha IS12/4000	MG180
TRxxx-xxx-xxxxx	365	365	192	Alpha IF22/3000	MG360
TRxxx-xxx-xxxxx	365	365	192	Alpha IF30/3000	MG180
TRxxx-xxx-xxxxx	900	900	250	Alpha IF30/3000	MG480

TRXXX-XXX-XXX-XXXX
<p>Table Class</p> <p>Headstock Class</p> <p>Tailstock Class</p> <p>Trunnion Ratio</p> <p>Motor</p>

MID HEADSTOCK/TAILSTOCK SPECIFICATIONS W/FANUC MOTOR

CLASS	MODEL#	AMPLIFIER	180° INDEX TIME (sec)	PAYLOAD (Kg)	PEAK RPM	ACCEL/DECEL (sec)	MAX CG OFF-SET (mm)	MAX ENVELOPE DIAMETER	MAX MOMENT OF INERTIA (kgm)
250	TR250-171-a8iF	aiSV-40	3	110	17.54	1.3	101	2250	538
	TR250-171-a8iS	aiSV-80	2	1000	23.39	0.72	101	1500	237
300	TR300-185-a12iF	aiSV-80	3	1900	16.22	1.15	101	2700	1302
	TR300-185-a12iS	aiSV-80	2	1900	21.62	0.61	101	1800	620
365	TR365-192-a22iF	aiSV-80	3	2500	15.63	1.08	101	2400	1377
	TR365-192-a30iF	aiSV-160	3	5000	15.63	1.08	101	2500	2969
900	TR900-250-a30iF	aiSV-160	3.5	6700	11.98	1	101	3150	6132
	TR300-250-a30iS	aiSV-160	3	5500	15.98	1.12	101	2800	4043
	TR900-250-a30iF	aiSV-160	5	6700	11.98	2.5	101	3700	8321

MID HEADSTOCK/TAILSTOCK SPECIFICATIONS W/KUKA MOTOR

CLASS	MODEL#	AMPLIFIER	180° INDEX TIME (sec)	PAYLOAD (Kg)	PEAK RPM	ACCEL/DECEL (sec)	MAX CG OFF-SET (mm)	MAX ENVELOPE DIAMETER	MAX MOMENT OF INERTIA (kgm)
250	TR250-171-MG180	KSD32	2	1000	23.39	0.72	101	1500	284
	TR250-171-MG110	KSD16	3	1100	17.54	1.3	101	2250	587
300	TR300-185-MG180	KSD48	2.25	1900	18.51	0.6	101	1800	620
	TR300-185-MG180	KSD32	3	1900	16.22	1.15	101	2700	1302
365	TR365-192-MG360	KSD64	3.25	5000	13.02	0.95	101	2500	2969
	TR365-192-MG180	KSD32	3	2500	15.63	1.08	101	2400	1377
900	TR900-250-MG360	KSD64	4	6700	9.99	1	101	3150	6132
	TR300-250-MG480	KSD64	5	6700	8.79	1.59	101	3700	8321



MOTION INDEX DRIVES

Flexible Positioning System
DR-TR Series

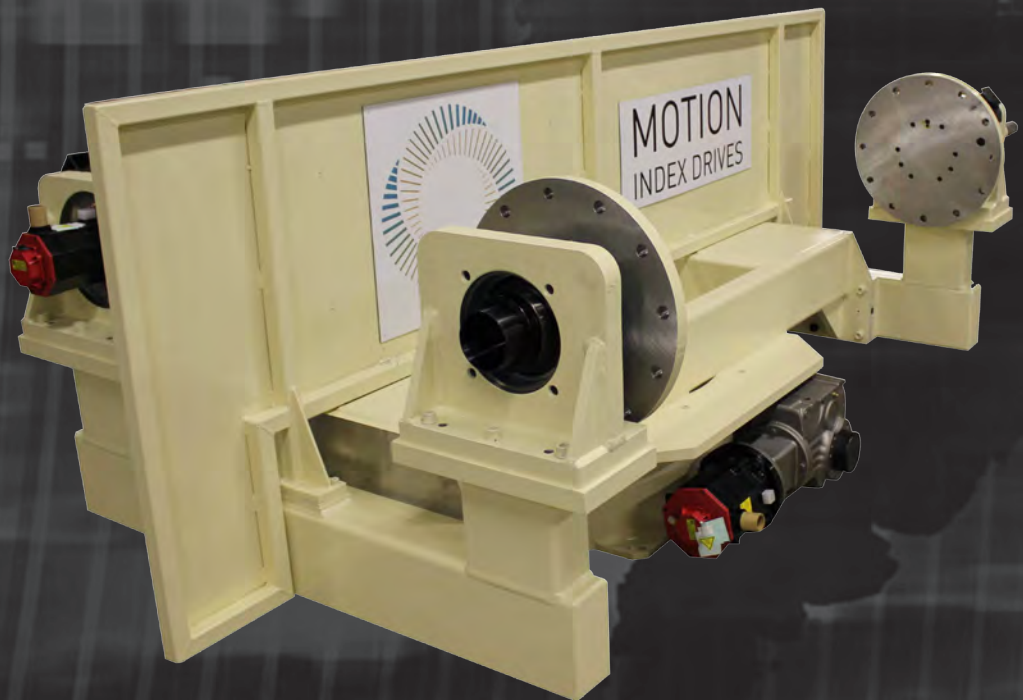



MOTION INDEX DRIVES

Motion Index Drives DR-TR Trunnion system is a complete 3 axis machine, designed and engineered to provide superior performance in demanding industrial automation environments. The DR-TR System is comprised of a base index drive, which can be either a fixed number of station index drive, or a programmable drive, which rotates a steel weldment. On this weldment are mounted two trunnion assemblies, each consisting of a head stock and tail stock. The system provides a superior accuracy, index time, and flexibility to meet the demands of modern automation systems. As each system is built for our customers needs, all dimensions can be adjusted to fit the application requirement.

Flexible Positioning System

Motion Index Drives programmable index drives all feature extremely high accuracy with high quality manufacturing and oversized components. All programmable index drives feature flame hardened constant lead barrel cams, which provide no backlash between top rotating dial and the cam itself, through the multiple cam followers engaged into the cam at all times. The large number of cam followers engaged in the cam allows for increased inertial loading capabilities along with the ability for very fast index times and very long life. The programmable index tables can be driven with either a 3 phase AC motor with encoder, or with a servo motor of choice. The encoder on the motor provides the position feedback of the index drive, and in many cases, an additional axis for a robot can be used to control the index table while utilizing the same brand servo as the robot. Programmable index tables provide infinite positioning while maintaining the same high quality and reliability of Motion Index Drives traditional fixed index drives.

Key Features and Benefits

- Infinite positioning and index angle is possible
- Multiple oversized cam followers engaged in cam at all times
- Minimal maintenance
- Can utilize any motor required (AC motor with encoder, servo, etc.)
- Range in all sizes of index drives
- Capable of both high speed applications and high load
- Extremely compact relative to inertial load capability

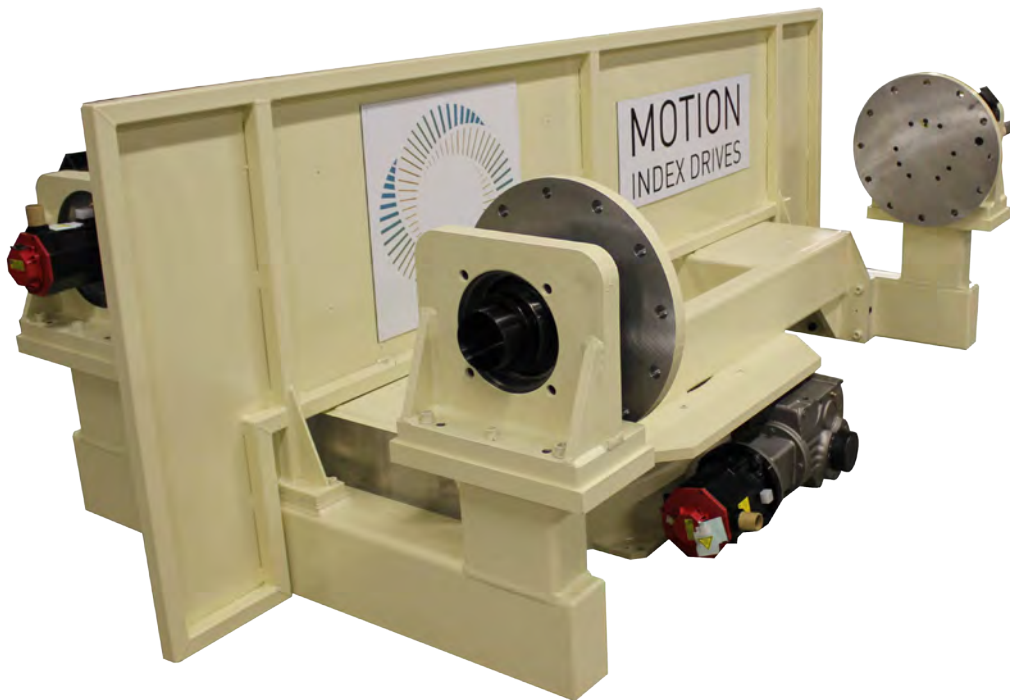

MOTION INDEX DRIVES DRTR DUAL TRUNNION SYSTEMS (All dimensions in mm)					
Assembly Number	Axis 1	Trunnion	Trunnion Ratio	Cl Height	Faceplate Width
TMF3000-TR250-171-750-2000-X	TMF3000	250	171	750	2000
TMF3000-TR250-171-750-2500-X	TMF3000	250	171	750	2500
TMF3000-TR250-171-750-3000-X	TMF3000	250	171	750	3000
TMF3000-TR250-171-900-2000-X	TMF3000	250	171	900	2000
TMF3000-TR250-171-900-2500-X	TMF3000	250	171	900	2500
TMF3000-TR250-171-900-3000-X	TMF3000	250	171	900	3000
TMF3000-TR300-185-750-2000-X	TMF3000	300	185	750	2000
TMF3000-TR300-185-750-2500-X	TMF3000	300	185	750	2500
TMF3000-TR300-185-750-3000-X	TMF3000	300	185	750	3000
TMF3000-TR300-185-900-2000-X	TMF3000	300	185	900	2000
TMF3000-TR300-185-900-2500-X	TMF3000	300	185	900	2500
TMF3000-TR300-185-900-3000-X	TMF3000	300	185	900	3000

TMF3000-TRXXX-XXX-XXX-XXXX
<p style="text-align: center;"> Table Class Trunnion Class Trunnion Ratio Cl Height Faceplate Width </p>

MID Standard Double Trunnion with Kuka Motors (other servo motors can be used)

CLASS	MODEL #	EXCHANGE AXIS MOTOR	EXCHANGE AXIS AMPLIFIER	TRUNNION AXIS MOTORS	TRUNNION AXIS DUAL AMPLIFIER	EXCHANGE 180° INDEX TIME	TRUNNION 180° INDEX TIME	EACH TRUNNION PAYLOAD	MAX TRUNNION ENVELOPE	MAX TRUNNION INERTIA	TRUNNION CENTER-LINE TO FLOOR DISTANCE	DISTANCE BETWEEN FACE PLATES
250	TMF3000-TR250-171-750-2000-X	MG360	KSD64	MG180	KSD32	4.5	2	1000	1400	237	750	2000
	TMF3000-TR250-171-750-2500-X	MG360	KSD64	MG180	KSD32	4.5	2	1000	1400	237	750	2500
	TMF3000-TR250-171-750-3000-X	MG480	KSD64	MG180	KSD32	4.5	2	1000	1400	237	750	3000
	TMF3000-TR250-171-900-2000-X	MG360	KSD64	MG180	KSD32	4.5	2	1000	1400	237	900	2000
	TMF3000-TR250-171-900-2500-X	MG360	KSD64	MG180	KSD32	4.5	2	1000	1400	237	900	2500
	TMF3000-TR250-171-900-3000-X	MG480	KSD64	MG180	KSD32	4.5	2	1000	1400	237	900	3000
300	TMF3000-TR300-185-750-2000-X	MG360	KSD64	MG180	KSD48	5	2	1818	1400	620	750	2000
	TMF3000-TR300-185-750-2500-X	MG360	KSD64	MG180	KSD48	5	2	1818	1400	620	750	2500
	TMF3000-TR300-185-750-3000-X	MG360	KSD64	MG180	KSD48	5	2	1818	1400	620	750	3000
	TMF3000-TR300-185-900-2000-X	MG360	KSD64	MG180	KSD48	5	2	1818	1400	620	900	2000
	TMF3000-TR300-185-900-2500-X	MG360	KSD64	MG180	KSD48	5	2	1818	1400	620	900	2500
	TMF3000-TR300-185-900-3000-X	MG360	KSD64	MG180	KSD48	5	2	1818	1400	620	900	3000

MID Standard Double Trunnion with Fanuc Motors (other servo motors can be used)

250	TMF3000-TR250-171-750-2000-X	A22IF	AISV-80	A8IS	AISV-80/80	4.5	2	1000	1400	237	750	2000
	TMF3000-TR250-171-750-2500-X	A22IF	AISV-80	A8IS	AISV-80/80	4.5	2	1000	1400	237	750	2500
	TMF3000-TR250-171-750-3000-X	A30IF	AISV-80	A8IS	AISV-80/80	4.5	2	1000	1400	237	750	3000
	TMF3000-TR250-171-900-2000-X	A22IF	AISV-80	A8IS	AISV-80/80	4.5	2	1000	1400	237	900	2000
	TMF3000-TR250-171-900-2500-X	A22IF	AISV-80	A8IS	AISV-80/80	4.5	2	1000	1400	237	900	2500
	TMF3000-TR250-171-900-3000-X	A30IF	AISV-80	A8IS	AISV-80/80	4.5	2	1000	1400	237	900	3000
300	TMF3000-TR300-185-750-2000-X	A22IF	AISV-80	A12IS	AISV-80/80	5	2	1818	1400	620	750	2000
	TMF3000-TR300-185-750-2500-X	A22IF	AISV-80	A12IS	AISV-80/80	5	2	1818	1400	620	750	2500
	TMF3000-TR300-185-750-3000-X	A22IF	AISV-80	A12IS	AISV-80/80	5	2	1818	1400	620	750	3000
	TMF3000-TR300-185-900-2000-X	A22IF	AISV-80	A12IS	AISV-80/80	5	2	1818	1400	620	900	2000
	TMF3000-TR300-185-900-2500-X	A22IF	AISV-80	A12IS	AISV-80/80	5	2	1818	1400	620	900	2500
	TMF3000-TR300-185-900-3000-X	A22IF	AISV-80	A12IS	AISV-80/80	5	2	1818	1400	620	900	3000



MOTION INDEX DRIVES

ADDITIONAL PRODUCTS & SERVICES



Trunnion Solutions

Motion can provide in addition to the trunnion headstock drive a complete trunnion assembly. The complete trunnion solutions we provide utilize our standard, high-reliability and precise indexing equipment with custom weldments that exceed our customers' expectations.

Features

- Headstock (RT, TR, and TMF Series)
- Tailstock (bearing assembly or thru-hole bearing housing)
- Center Frame (custom length and weldment design)
- Optional Controls Drive for Motor
- Optional Micarta isolation kits
- Customer specified paint finish on all stationary components
- Black oxide head and tailstock flanges

Benefits

- Purchase multiple components from one source reducing purchasing management time
- Reduce project management time by utilizing Motion to order necessary components
- Minimize your design time by utilizing our standard designs that are readily available
- Minimize assembly time while decreasing your required man hours on your projects
- We will mount customer supplied motors and other
- Minimize shipping and handling cost by purchasing from one source



Rotary Index Table Tooling Frames

Tooling frames and weldments can be manufactured to our customers print. These can be delivered complete with our index drives, to allow for a simpler installation. Weldments can be manufactured to your drawings and can be offered upon receipt of the drawing for quoting.

Features

- Available in extremely low profile designs
- A-Frame, H-Frame welded structures to meet ergonomic load requirements
- FEA studies completed by Motion based on your tooling/fixture loads
- Reduce mass moment of inertia by utilizing our design experience
- Machine enamel, Epoxy or Powder Coating to customers color spec.
- Frames manufactured to allow customer to simply bolt on tooling and fixtures

Benefits

- Purchase multiple components from one source reducing purchasing management time
- Reduce project management time by utilizing Motion to order necessary components
- Minimize your design time by utilizing our standard designs that are readily available
- Minimize assembly time while decreasing your required man hours on your projects
- We will mount customer supplied motors and other
- Minimize shipping and handling cost by purchasing from one source

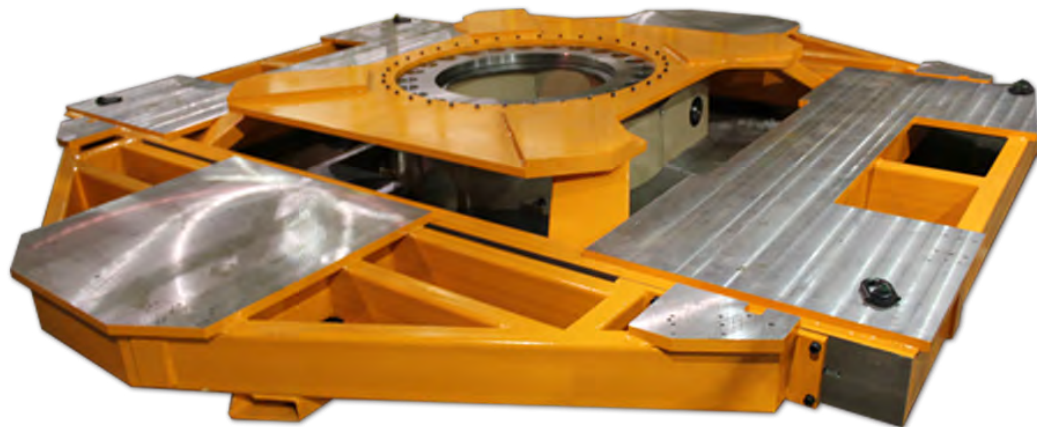

Motion Index Drives can supply any dial plate required, made from nearly any material, including steel, aluminum, and plastics. Simply specify the thickness, diameter, material and special coatings (if required) of the plate and we will supply this with the index drive complete. We can also have the dial plate machined to your drawing, allowing for less work for our customers.

Features

- Round, rectangle, triangle or custom shape
- Machining to your print
- Special tolerances
- Bushings
- Thread inserts
- Anodizing
- Nickel plating
- Stainless steel
- Black oxide
- Teflon

Benefits

- Purchase multiple components from one source reducing purchasing management time
- Reduce project management time by utilizing Motion to order necessary components
- Minimize your design time by utilizing our standard designs that are readily available
- Minimize assembly time while decreasing your required man hours on your projects
- We will mount customer supplied motors and other
- Minimize shipping and handling cost by purchasing from one source

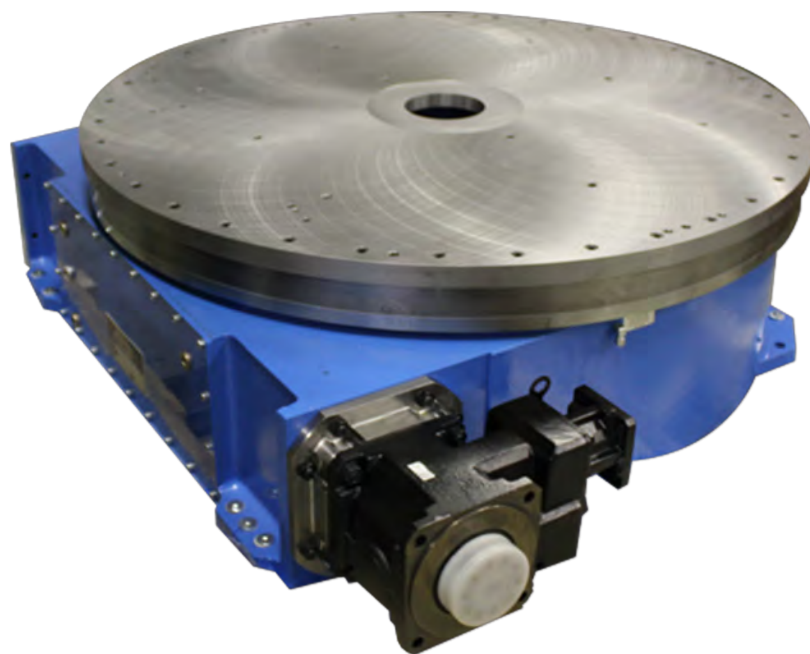

Machine Bases

Machine bases can be manufactured to our customers print or we can recommend a standard base to fit. These can be delivered complete with our index drives, to allow for a simpler installation. Bases can be manufactured to your drawings and can be offered upon receipt of the drawing for quoting.

Features

- Many different hollow structural tubular frame choice
- Aluminum Anodized and Stainless Steel Top Plates
- Steel top plates
- Nickel, Black Oxide or other finishing available
- Surface ground for precision
- Leveling and tie down foot pads
- Casters for mobility if required
- Machine enamel, Epoxy or Powder Coating to customers color spec.

Benefits

- Purchase multiple components from one source reducing purchasing management time
- Reduce project management time by utilizing Motion to order necessary components
- Minimize your design time by utilizing our standard designs that are readily available
- Minimize assembly time while decreasing your required man hours on your projects
- We will mount customer supplied motors and other
- Minimize shipping and handling cost by purchasing from one source

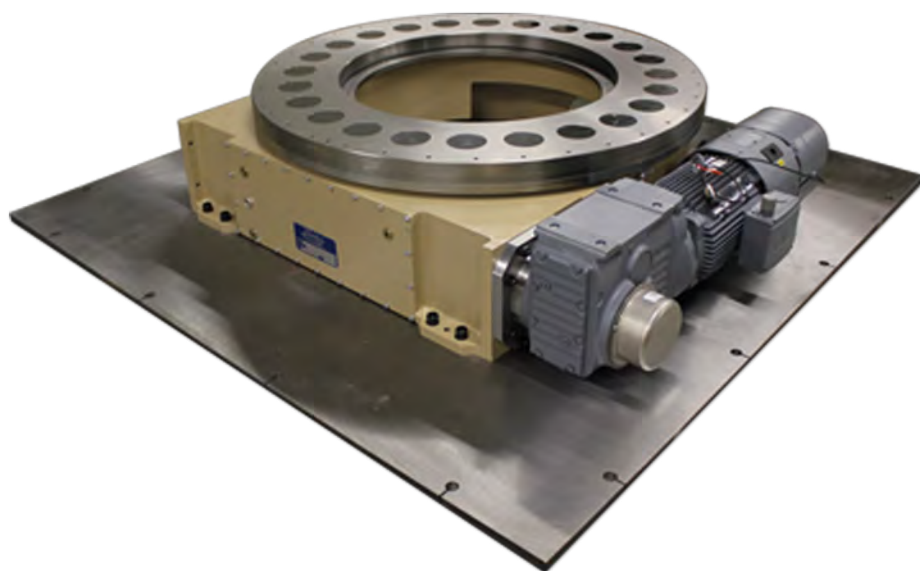

TripleDex Indexer

Motion's Multidex Indexer solution provides one large base rotary index table with smaller satellite indexers. This allows the tooling or part to be rotated on one end of the work cell while the other end can be safely interfaced or rotated to allow for different access. The standard units include a base rotary index table with 2, 3 or 4 satellite indexers. The base and satellite indexers can have either a fixed or flexible number of stations. Multidex units come complete with baseplate or base frame ready to be mounted in your cell.

Features

- Utilizes high precision TMF or RT series rotary index tables
- Complete with high voltage slip ring to power satellite indexers
- Large through hole on base indexer in the housing and in the center
- Through holes enable you to run utilities at ground level
- Absolute encoder on satellite indexer input shaft for high accuracy
- Special sealing on all indexers for harsh environments

Benefits

- Purchase multiple components from one source reducing purchasing management time
- Reduce project management time by utilizing Motion to order necessary components
- Minimize your design time by utilizing our standard designs that are readily available
- Minimize assembly time while decreasing your required man hours on your projects
- We will mount customer supplied motors and other
- Minimize shipping and handling cost by purchasing from one source



Other Complimentary Components

Slip Rings / Rotary Unions

Our MSR series rotary union / slip ring assembly can be manufactured to our customer's specification. These can be delivered complete with our index drives, to allow for a simpler installation.



Features

- Low and high voltage capabilities from 24 VDC up to 600 VAC 3 phase
- Single circuit up to 96 circuits
- Multiple or single air or fluid ports ranging in size 1/8" to 1 1/2" dia.
- Device Net, Profibus, USB, CanBus and ProfiNet compatible
- Rotary union is capable to transmit air or fluids
- Special connections available for data and electrical
- Custom tail connections with customer specified lengths

Benefits

- Purchase multiple components from one source reducing purchasing management time
- Reduce project management time by utilizing Motion to order necessary components
- Minimize your design time by utilizing our standard designs that are readily available
- Minimize assembly time while decreasing your required man hours on your projects
- We will mount customer supplied motors and other
- Minimize shipping and handling cost by purchasing from the source

Switch Packages

- Encoders
- Proximity Switches
- Mechanical Switches

Tooling and Accessories

- Adapter Plates
- Dial Plates
- Base Plates
- Trunnion Riser Weldments
- Pillow Blocks for Trunnion Mounting
- Mechanical Safety Lock-Outs
- Satellite Index Drive Machines
- Partially Built Indexer Cells

Motors and Reducers

- Explosion-Proof Motors
- Servo Motors
- Stainless Steel Motors

Low-Backlash Gear Reducers

Custom Cams

- Custom Auxiliary Cam operations
- Custom Cams to implement into existing operation

Custom Coatings

- Powder Coatings
- Nickel Plating
- Anodizing
- Stainless Steel
- Black Oxide

Controls

- VFD's
- Servo Drives
- Complete Integrated Index Drive Control Panel

Services

Motion Index Drives offers extensive support for new startup and existing products. If you are in search of product information regarding installation, CAD drawings and/or maintenance manuals, please visit our website downloads section.

- On-Site Support
 - Repairs
 - Installs
- Refurbishing
 - Customers can send their units back to Motion and have certified technicians refurbish their equipment back to new
- Retrofitting
- Training and certification courses for large projects implementation
- Replacement motors
- Recycling of old turntables

On-Site

All on site service is performed by a certified Motion Index Drives technician with minimum 5 years of experience. Our customers will benefit from a full warranty on refurbished units. Any parts needing to be replaced will have 100% Motion Index Manufactured components used where applicable. All components will be adjusted to original manufactured specifications when applicable. Our technicians can provide preventative maintenance programs. All of our technicians are available for 24 hour emergency breakdowns. To schedule a service call to your facility please contact Motion Index Drives at 1-248-743-9999.

At Facility

Our technicians can perform a full disassembly to inspect all major components. Any components that are replaced will be adjusted to original manufacturing specifications, all units we be re-tested before leaving our facility. Our customer receives full warranty on repaired units. Motion Index Drives can also arrange pickup and delivery of equipment. Please contact Motion Index Drives at 1-248-743-9999.

Spare Parts

When calling to order spare parts, please have our shop order number available to give to our Service and Parts Department to ensure that you will be getting the correct parts for your specific unit. The shop order number can be found on our nameplate located on each unit. Spare parts are very important for our customers to have on hand. In the event a customer has a "crash" (robot crashing into tooling) internal components could have unnecessary forces applied to them and may become damaged. This could then cause down time to your line. When customers stock our spare parts the down time is kept to a minimum. The most common spare parts to have on hand are cam followers, seals, and bearings for your specific unit.

NANO Indexer Technology

Motion Index Drives' NANO Index Technology is a series of barrel cam indexers equipped with a specially designed cam to achieve extremely high accuracies. This line is the most accurate series of barrel cam indexers in the world, with accuracies as high as 0.002 mm or 0.0001". Motion's NANO Index Technology can be used for any application where extremely high accuracy and repeatability is required, such as electronic device assembly, microchip assembly, circuit board assembly, microscopic movement, laser interfaced applications, precision medical equipment manufacturing or 4-color printing applications.

Advantages for Designers and Machine Builders

- Oscillating index operation capabilities
- Easy synchronization of other mechanical devices
- Large center thru-hole to feed pneumatic, electrical and other lines
- Housing machined on all sides for use in any mounting position

Options Available

- Reinforced output flange
- Nickel-plated output flange and shafts
- Special output flange adapters to seal out any contaminants
- Custom index and dwell angles
- Clean room ready with MEDEX Index Drives

Technical Benefits for End Users

- NANO Index Technology is applied to our standard line of Rotary Index Drives
- In-station true accuracy of 0.002 mm (0.0001"), 8 arc seconds or better
- NANO equipped indexers actively seek dwell
- Equipped with servo motor
- This unit can offer nearly 100% accuracy and repeatability

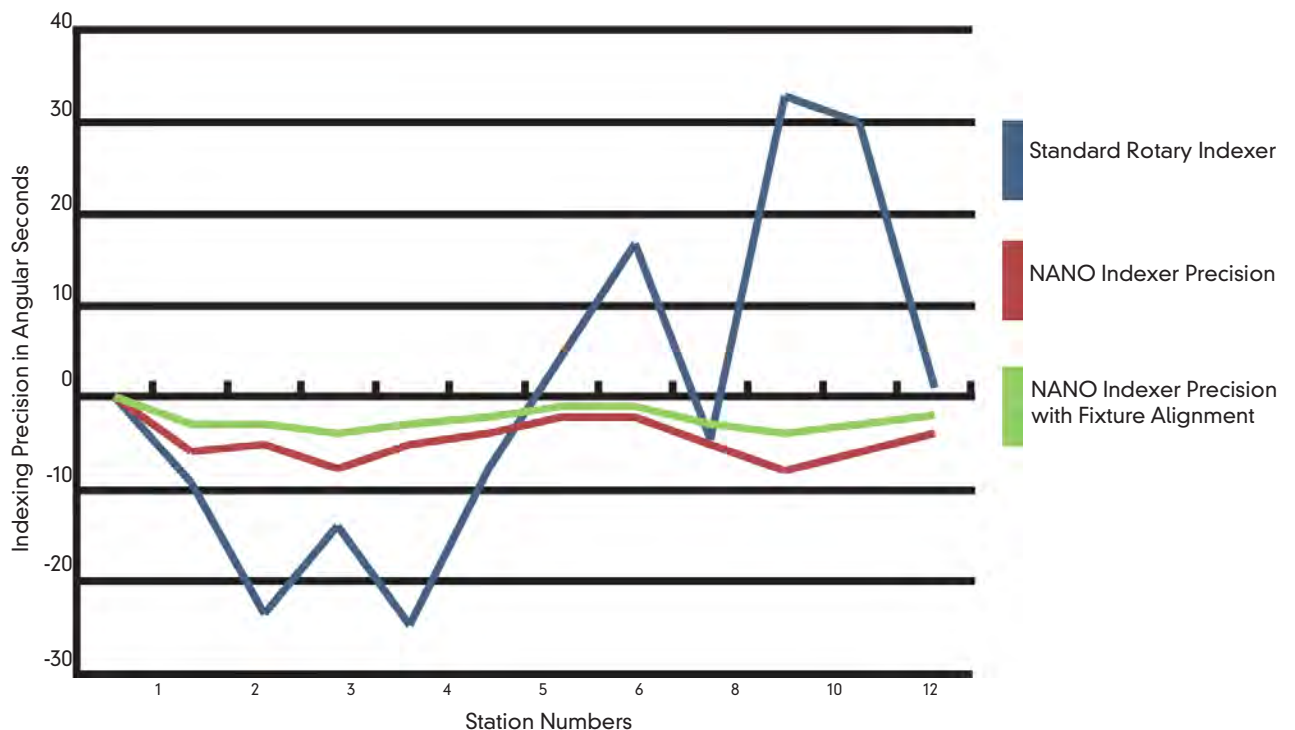

Clean Room Solutions

Clean room environments place the very highest demands on equipment, protection of people, assets and processes due to the high-risk substances, cross-contamination risks and very stringent regulatory requirements. At Motion Index Drives we have not only met but continuously exceed these demands to produce the highest quality clean room ready indexing devices on the market. The Motion Index Drives **MEDEX line** brings a variety of solutions to all of Motion's standard products. The **MEDEX line** is ready to be placed in clean room environments, such as manufacturing settings for medical equipment, pharmaceuticals, microelectronics and food processing. Our complete line of indexing equipment can be ordered to exceed all clean room requirements.

Advantages for Designers and Machine Builders

- Oscillating index operation capabilities
- Easy synchronization of other mechanical devices
- Large center thru-hole to feed pneumatic, electrical and other lines
- Housing machined on all sides for use in any mounting position



Technical Benefits for End Users

- Utilizes the same reliable and high-quality technologies as our standard line of indexing equipment
- Meets the requirements for clean room environments
- Stainless steel, nickel plating, or other
- Sealed with medically-approved seals
- Paint and aluminum treatments on the index drive and gear motor

Options Available

- Custom index and dwell angles
- Specified motors and reducers (TEFC, Motor Coatings, special oil filled reducers)
- User-controlled stations and timing with the MOTION Flex line
- More Options



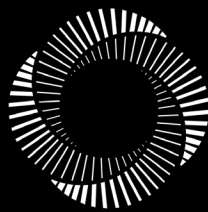

MOTION

INDEX DRIVES

www.mid.us.com
p. 248.743.9999 • f. 248.743.0749
1204 E Maple • Troy, MI 48083