

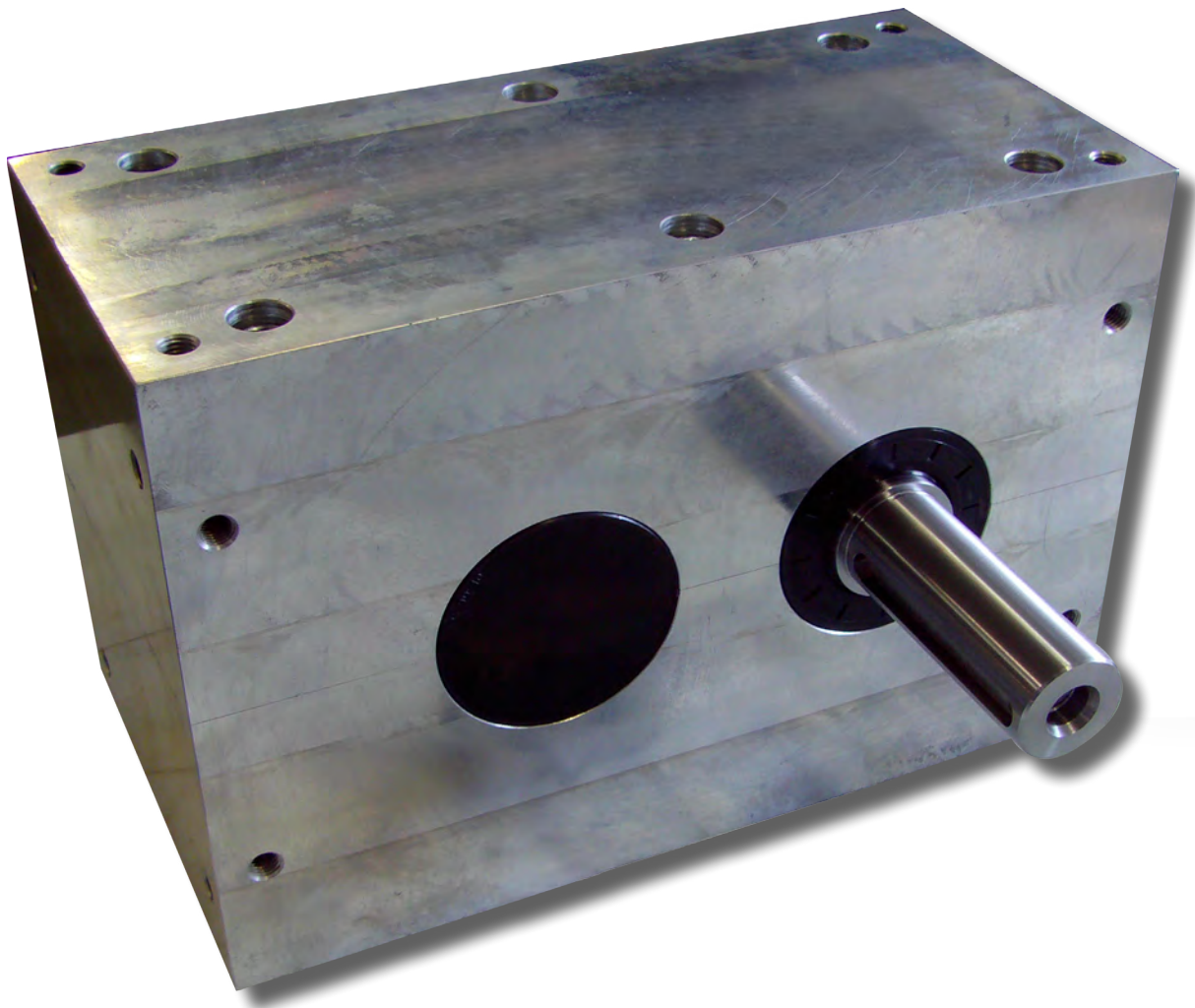

MOTION
INDEX DRIVES

Parallel Index Drives

TP Series



Quality in Motion Since 1970

Calculations

J = moment of inertia

$$M_B = c_a \times n \frac{2\pi}{n \times t^2}$$

$$M_R = \mu \times g \times R \times m$$

$$M_{AB} = M_B + M_R + (M_{ST})^*$$

$$M_{ST} = m \times g \times R$$

$$M_{AN} = ((M_B \times c_m) + (M_{ST} \times C_v)) \times \frac{360^\circ}{n \times a}$$

$$P = \frac{M_{AN} \times f_a}{9550 \times n}$$

*with one-sided lifting of loads

J = moment of inertia [kgm²]

M_B = acceleration torque [Nm]

M_R = friction torque [Nm]

M_{AB} = indexer torque [Nm]

M_{ST} = static torque [Nm]

M_{AN} = drive torque [Nm]

μ = friction coefficient

g = acceleration of gravity = 9,81m/s²

R = radius

m = mass [kg]

a = switching angle [°]

t_s = index time [s]

n = number of stops

i = ratio

P = drive power [kW]

n = efficiency worm gear

f_a = drive speed [1/min]

MS = ACCELERATION	MS0	MS30	M250
c _a = acceleration coefficient	5.53	6.41	8.01
c _m = performance coefficient	0.99	0.81	0.72
c _v = speed coefficient	1.76	1.43	1.27

Sorting and Isolation

$$M_{AB} = M_B + M_{ST}$$

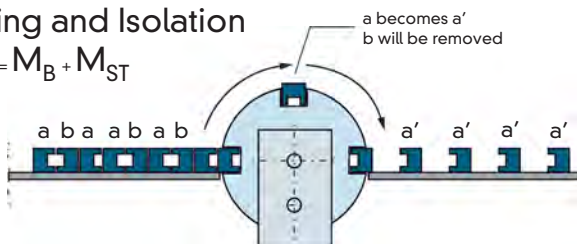

Application examples

Direct driven belt/chain

$$M_{AB} = M_B + M_B$$

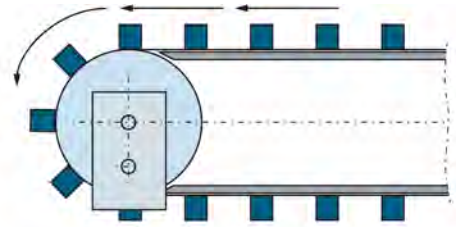

Indirect driven belt/chain

$$M_{AB} = \frac{M_B}{i^2} + \frac{M_R}{i}$$

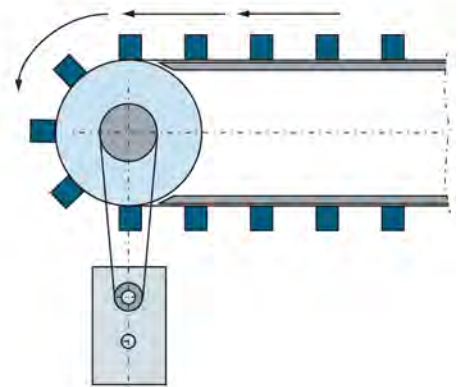

Arm

$$M_{AB} = M_B + M_{ST}$$

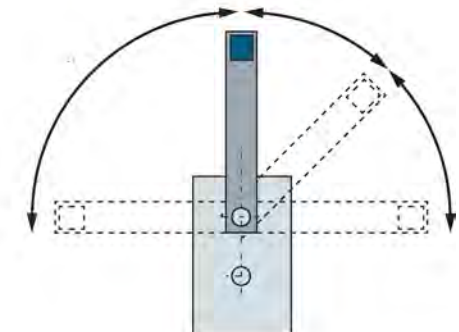

Transducer of rotations in horizontal movement

$$M_{AB} = M_B + M_R$$

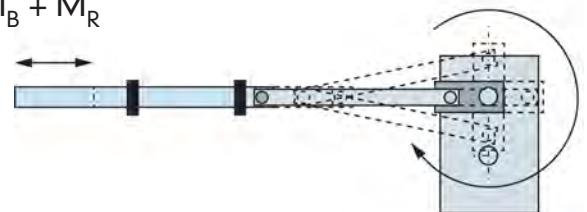

Rotate part

$$M_{AB} = M_B$$



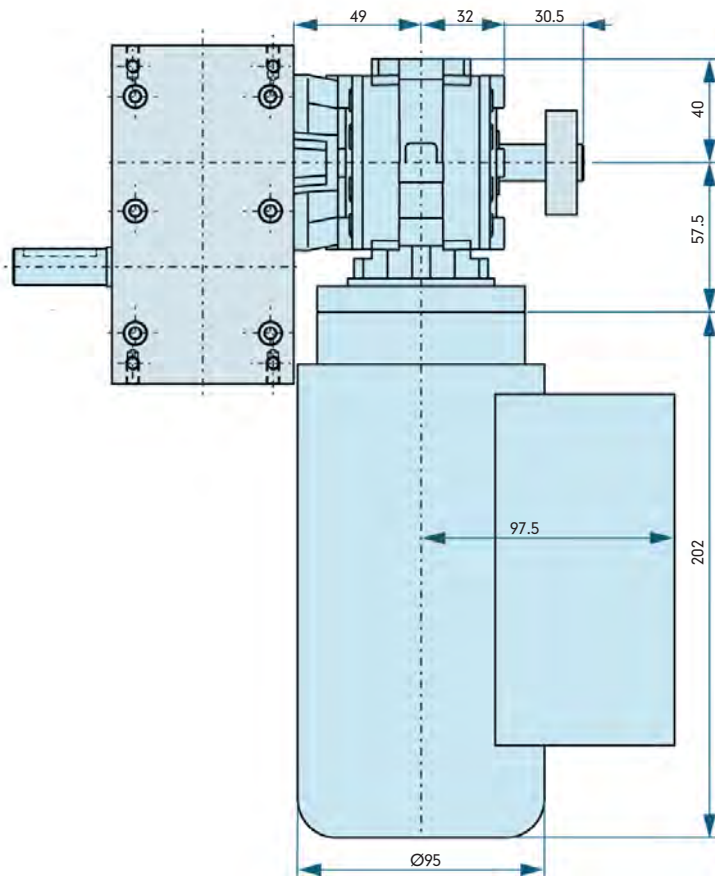
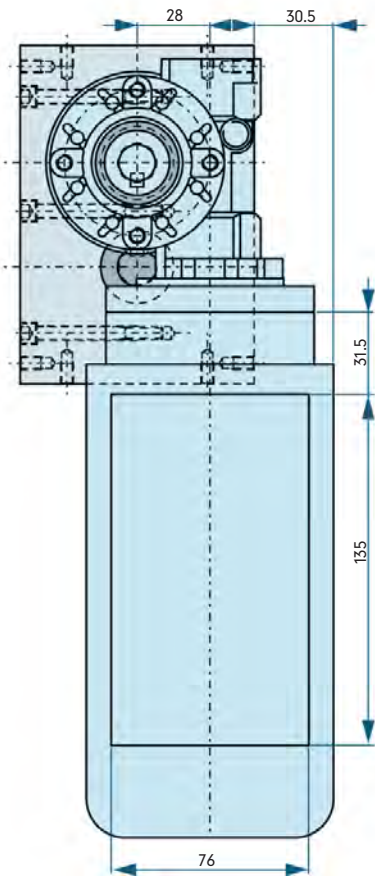
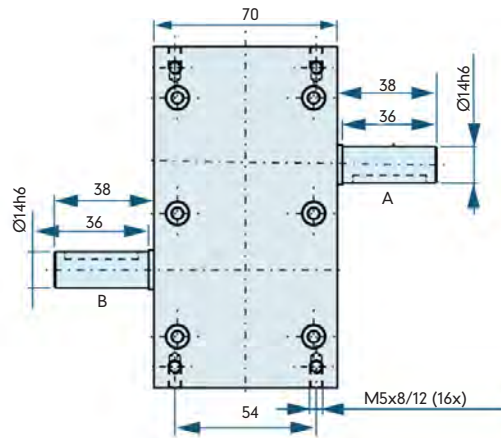
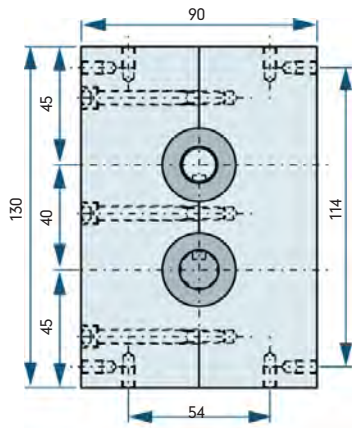

TP040 Dimensions

The measurements shown here illustrate the standard unit. We will gladly customize the housing and or shaft(s) to suit your needs. The drive shaft as well as the output shaft are available as double sided shafts with and without keyways. If you would like to add additional holes into the housing yourself, please contact us for possible drilling depths.

A = Drive Shaft

B = Output Shaft



The dimensions for the gearmotor may change based on the gearmotor size and options required for the application.

TP040 Load Table

Angle on Output Shaft [°]	Number of Stops n	Index Angle [°]	Acceleration Form MS	Indexer Torque M_{AB} [Nm]			Moment of Inertia J [kgm ²]			Mechanical Index Time t_s [S]		
				n=50	n=100	n=200	n=50	n=100	n=200	n=50	n=100	n=200
360°	1	330	MS30	29	25	21	0.56	0.12	0.03	1.1	0.55	0.28
		300	MS50	28	24	20	0.56	0.12	0.02	1	0.5	0.25
180°	2	270	MS0	32	27	24	1.03	0.22	0.05	0.9	0.45	0.23
		210	MS30	26	24	21	0.59	0.14	0.03	0.7	0.35	0.18
		150	MS50	25	23	20	0.2	0.05	0.01	0.5	0.25	0.13
120°	3	270	MS0	39	33	26	2.18	0.46	0.09	0.9	0.45	0.23
		210	MS30	29	33	26	1.14	0.24	0.05	0.7	0.35	0.18
		150	MS30	33	27	23	0.49	0.1	0.02	0.5	0.25	0.13
		120	MS30	30	25	20	0.29	0.06	0.01	0.4	0.2	0.1
90°	4	270	MS0	36	30	24	2.69	0.56	0.11	0.9	0.45	0.23
		210	MS0	36	30	24	1.63	0.34	0.07	0.7	0.35	0.18
		150	MS30	35	29	23	0.7	0.14	0.03	0.5	0.25	0.13
		90	MS30	32	28	21	0.23	0.05	0.01	0.3	0.15	0.08
72°	5	270	MS0	36	30	24	3.36	0.7	0.14	0.9	0.45	0.23
		210	MS0	36	30	24	2.03	0.42	0.08	0.7	0.35	0.18
		150	MS30	35	29	23	0.87	0.18	0.04	0.5	0.25	0.13
		90	MS30	32	28	21	0.29	0.06	0.01	0.3	0.15	0.08
60°	6 ¹⁾	270	MS0	42	34	28	4.7	0.95	0.2	0.9	0.45	0.23
		240	MS0	42	34	28	3.72	0.75	0.15	0.8	0.4	0.2
		180	MS30	40	32	25	1.72	0.34	0.07	0.6	0.3	0.15
		120	MS30	36	29	22	0.69	0.14	0.03	0.4	0.2	0.1
45°	8 ¹⁾	270	MS0	42	34	28	6.27	1.27	0.26	0.9	0.45	0.23
		240	MS0	42	34	28	4.95	1	0.21	0.8	0.4	0.2
		180	MS30	40	32	25	2.29	0.46	0.09	0.6	0.3	0.15
		120	MS30	36	29	22	0.92	0.18	0.03	0.4	0.2	0.1
36°	10 ¹⁾	270	MS0	42	34	28	7.84	1.59	0.33	0.9	0.45	0.23
		240	MS0	42	34	28	6.19	1.25	0.26	0.8	0.4	0.2
		180	MS30	40	32	25	2.86	0.57	0.11	0.6	0.3	0.15
		120	MS30	36	29	22	1.14	0.23	0.04	0.4	0.2	0.1

¹⁾ Parallel drives with stop numbers 6, 8 and 10 are designed as a double index, i.e. with each full rotation of the drive shaft, two indexes occur in the output.

²⁾ Parallel drives with 12 stops are designed as a four step index, i.e. with each full rotation of the drive shaft, four indexes occur in the output.

³⁾ The additional load occurring with chains and belts due to friction is not taken into consideration here and must be calculated separately.

Main Dimensions

Shaft distance [mm]	40
Weight without drive [kg]	2
Switching angle [°]	see Load Table
(other switching angles upon request)	
Number of stops	1,2,3,4,5,6,8,10
(other numbers of stops upon request)	
Rotating direction	right, left, oscillating
Mounting position	ANY

Capacities

Max. Output torque	See Load Table
Input Shaft	
Load rating dynamic [kN]	4.36
Load rating static [kN]	2.24
Output Shaft	
Load rating dynamic [kN]	4.36
Load rating static [kN]	2.24

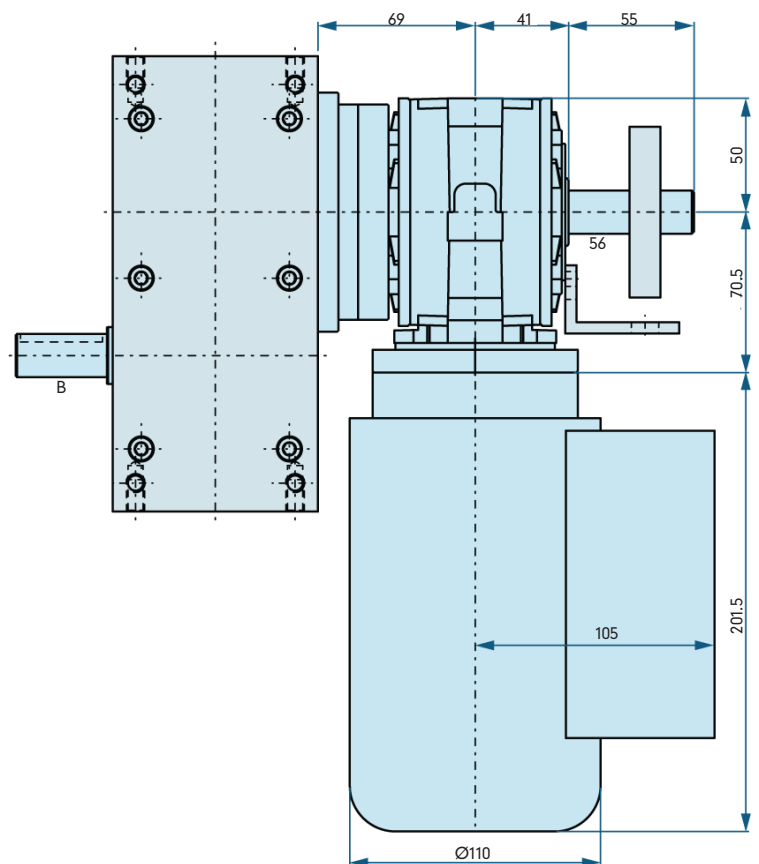
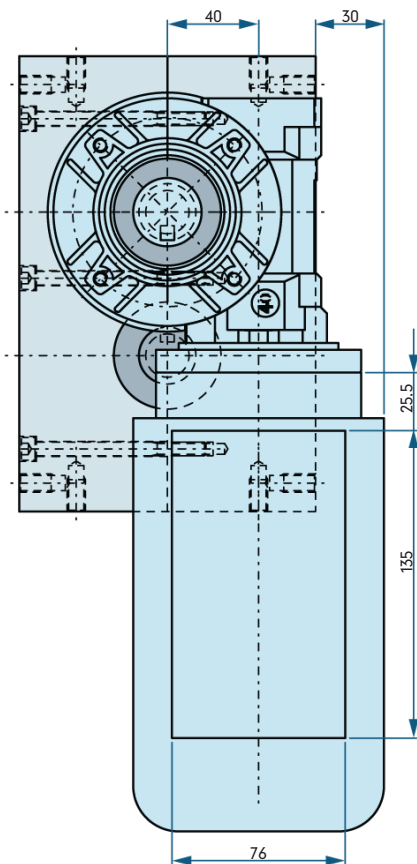
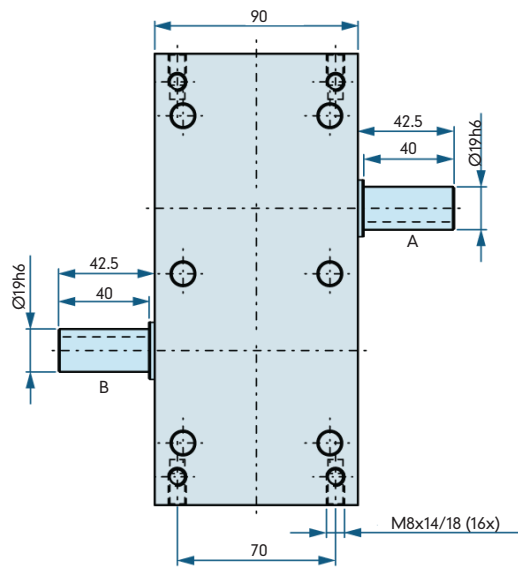
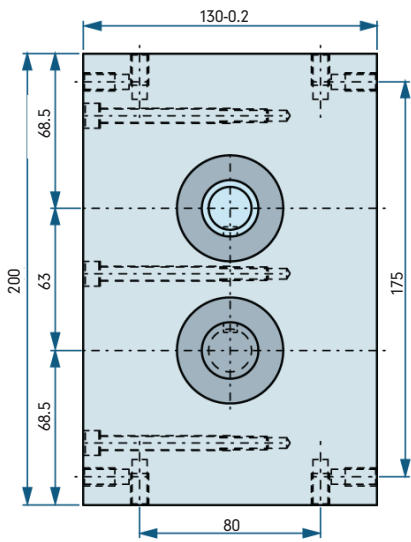

TP063 Dimensions

The measurements shown here illustrate the standard unit. We will gladly customize the housing and or shaft(s) to suit your needs. The drive shaft as well as the output shaft are available as double sided shafts with and without keyways. If you would like to add additional holes into the housing yourself, please contact us for possible drilling depths.

A = Drive Shaft

B = Output Shaft



The dimensions for the gearmotor may change based on the gearmotor size and options required for the application.

TP063 Load Table

Angle on Output Shaft [°]	Number of Stops n	Index Angle [°]	Acceleration Form MS	Indexer Torque M_{AB} [Nm]			Moment of Inertia J [kgm ²]			Mechanical Index Time t_s [S]		
				n=50	n=100	n=200	n=50	n=100	n=200	n=50	n=100	n=200
360°	1	330	MS30	52	43	36	1	0.2	0.04	1.1	0.55	0.28
		300	MS50	48	39	30	1	0.2	0.04	1	0.5	0.25
180°	2	270	MS0	58	51	43	1.9	0.4	0.09	0.9	0.45	0.23
		210	MS30	48	46	41	1.1	0.3	0.06	0.7	0.35	0.18
		150	MS50	42	40	39	0.3	0.1	0.02	0.5	0.25	0.13
120°	3	270	MS0	74	68	59	4.1	1	0.21	0.9	0.45	0.23
		210	MS30	73	67	57	2.1	0.5	0.1	0.7	0.35	0.18
		150	MS30	61	53	46	0.9	0.2	0.04	0.5	0.25	0.13
		120	MS30	60	52	43	0.6	0.1	0.03	0.4	0.2	0.1
90°	4	270	MS0	68	61	53	5.1	1.1	0.25	0.9	0.45	0.23
		210	MS0	66	59	51	3	0.7	0.14	0.7	0.35	0.18
		150	MS30	64	57	49	1.3	0.3	0.06	0.5	0.25	0.13
		90	MS30	64	57	49	0.5	0.1	0.02	0.3	0.15	0.08
72°	5	270	MS0	68	61	53	6.3	1.4	0.31	0.9	0.45	0.23
		210	MS0	66	59	51	3.7	0.8	0.18	0.7	0.35	0.18
		150	MS30	64	57	49	1.6	0.4	0.08	0.5	0.25	0.13
		90	MS30	64	57	49	0.6	0.1	0.03	0.3	0.15	0.08
60°	6 ¹	270	MS0	86	71	56	9.6	2	0.39	0.9	0.45	0.23
		240	MS0	83	69	54	7.3	1.5	0.3	0.8	0.4	0.2
		180	MS30	79	65	51	3.4	0.7	0.14	0.6	0.3	0.15
		120	MS30	75	61	46	1.4	0.3	0.05	0.4	0.2	0.1
45°	8 ¹	270	MS0	86	71	56	12.8	2.6	0.52	0.9	0.45	0.23
		240	MS0	83	69	54	9.8	2	0.4	0.8	0.4	0.2
		180	MS30	79	65	51	4.5	0.9	0.18	0.6	0.3	0.15
		120	MS30	75	61	46	1.9	0.4	0.07	0.4	0.2	0.1
36°	10 ¹	270	MS0	86	71	56	16	3.3	0.65	0.9	0.45	0.23
		240	MS0	83	69	54	12.2	2.5	0.5	0.8	0.4	0.2
		180	MS30	79	65	51	5.7	1.2	0.23	0.6	0.3	0.15
		120	MS30	75	61	46	2.4	0.5	0.09	0.4	0.2	0.1
30°	12 ²	240	MS0	62	51	39	11	2.3	0.43	0.8	0.4	0.2

¹) Parallel drives with stop numbers 6, 8 and 10 are designed as a double index, i.e. with each full rotation of the drive shaft, two indexes occur in the output.

²) Parallel drives with 12 stops are designed as a four step index, i.e. with each full rotation of the drive shaft, four indexes occur in the output.

³) The additional load occurring with chains and belts due to friction is not taken into consideration here and must be calculated separately.

Main Dimensions

Shaft distance [mm]	63
Weight without drive [kg]	8
Switching angle [°]	see Load Table
(other switching angles upon request)	
Number of stops	1,2,3,4,5,6,8,10,12
(other numbers of stops upon request)	
Rotating direction	right, left, oscillating
Mounting position	ANY

Capacities

Max. Output torque	See Load Table
Input Shaft	
Load rating dynamic [kN]	11.9
Load rating static [kN]	6.55
Output Shaft	
Load rating dynamic [kN]	8.06
Load rating static [kN]	4.75

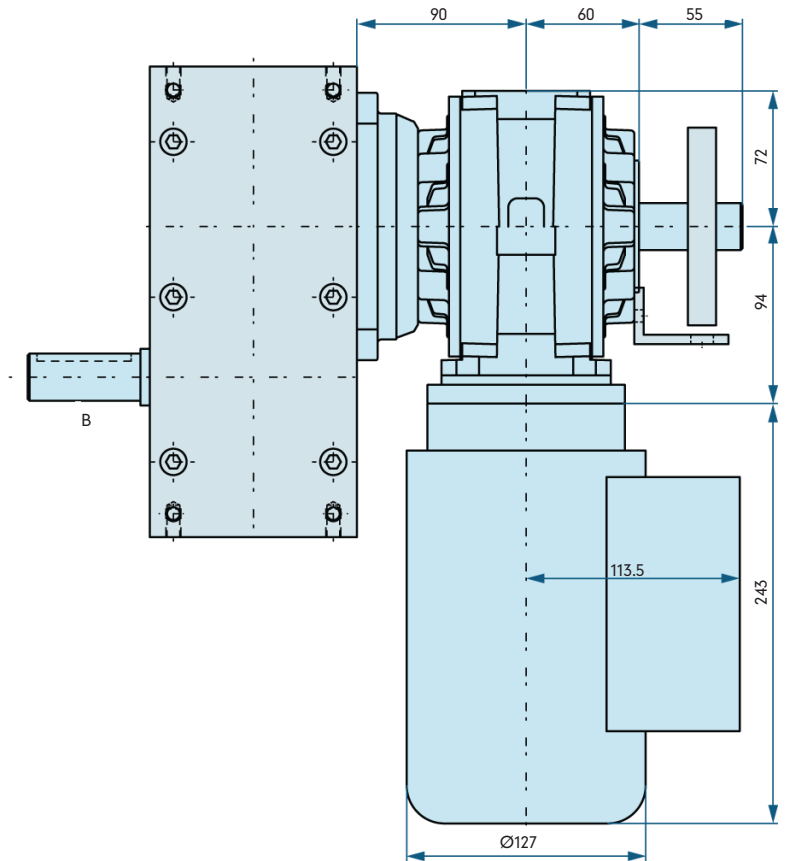
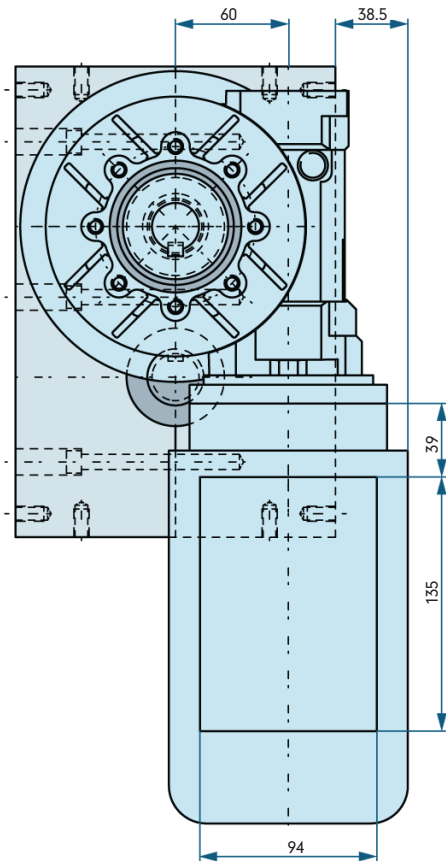
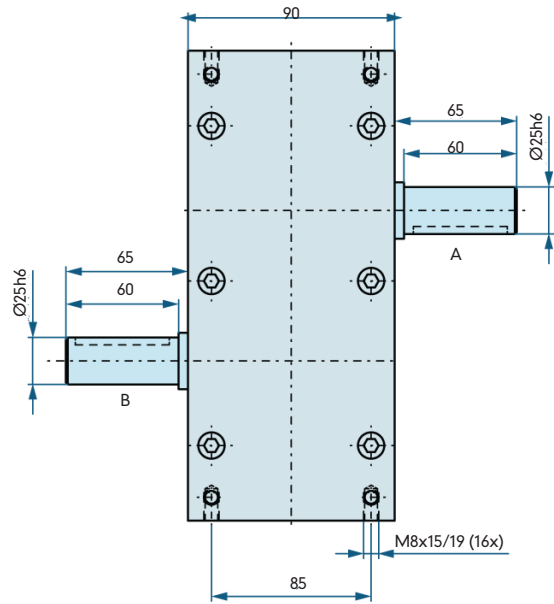
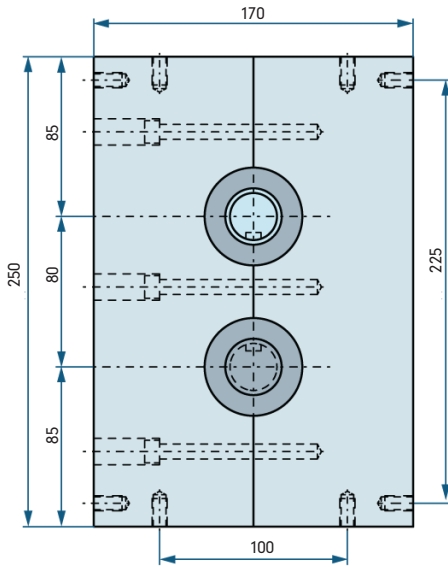

TP080 Dimensions

The measurements shown here illustrate the standard unit. We will gladly customize the housing and or shaft(s) to suit your needs. The drive shaft as well as the output shaft are available as double sided shafts with and without keyways. If you would like to add additional holes into the housing yourself, please contact us for possible drilling depths.

A = Drive Shaft

B = Output Shaft



The dimensions for the gearmotor may change based on the gearmotor size and options required for the application.

TP080 Load Table

Angle on Output Shaft [°]	Number of Stops n	Index Angle [°]	Acceleration Form MS	Indexer Torque M_{AB} [Nm]			Moment of Inertia J [kgm ²]			Mechanical Index Time t_s [S]		
				n=50	n=100	n=200	n=50	n=100	n=200	n=50	n=100	n=200
360°	1	330	MS30	124	102	81	2.4	0.5	0.1	1.1	0.55	0.28
		300	MS50	123	101	79	2.4	0.5	0.1	1	0.5	0.25
180°	2	270	MS0	132	107	93	4.2	0.9	0.19	0.9	0.45	0.23
		210	MS30	131	107	93	3	0.6	0.13	0.7	0.35	0.18
		150	MS50	103	96	89	0.8	0.2	0.04	0.5	0.25	0.13
120°	3	270	MS0	159	137	112	8.9	1.9	0.39	0.9	0.45	0.23
		210	MS30	152	129	101	4.4	0.9	0.18	0.7	0.35	0.18
		150	MS30	127	103	83	1.9	0.4	0.08	0.5	0.25	0.13
		120	MS30	119	97	78	1.1	0.2	0.05	0.4	0.2	0.1
90°	4	270	MS0	157	132	109	11.7	2.5	0.51	0.9	0.45	0.23
		210	MS0	151	126	96	6.8	1.4	0.27	0.7	0.35	0.18
		150	MS30	138	112	88	2.7	0.6	0.11	0.5	0.25	0.13
		90	MS30	118	92	76	0.8	0.2	0.03	0.3	0.15	0.08
72°	5	270	MS0	157	132	109	14.6	3.1	0.64	0.9	0.45	0.23
		210	MS0	151	126	96	8.5	1.8	0.34	0.7	0.35	0.18
		150	MS30	138	112	88	3.4	0.7	0.14	0.5	0.25	0.13
		90	MS30	118	92	76	1.1	0.2	0.04	0.3	0.15	0.08
60°	6 ¹	270	MS0	186	149	124	20.8	4.2	0.87	0.9	0.45	0.23
		240	MS0	174	146	120	15.4	3.2	0.66	0.8	0.4	0.2
		180	MS30	160	122	96	6.9	1.3	0.26	0.6	0.3	0.15
		120	MS30	132	105	81	2.5	0.5	0.1	0.4	0.2	0.1
45°	8 ¹	270	MS0	186	149	124	27.8	5.6	1.16	0.9	0.45	0.23
		240	MS0	174	146	120	20.5	4.3	0.88	0.8	0.4	0.2
		180	MS30	160	122	96	9.2	1.7	0.34	0.6	0.3	0.15
		120	MS30	132	105	81	3.4	0.7	0.13	0.4	0.2	0.1
36°	10 ¹	270	MS0	186	149	124	34.7	7	1.45	0.9	0.45	0.23
		240	MS0	174	146	120	25.7	5.4	1.11	0.8	0.4	0.2
		180	MS30	160	122	96	11.4	2.2	0.43	0.6	0.3	0.15
		120	MS30	132	105	81	4.2	0.8	0.16	0.4	0.2	0.1
30°	12 ²	240	MS0	110	95	76	19.5	4.2	0.84	0.8	0.4	0.2

¹) Parallel drives with stop numbers 6, 8 and 10 are designed as a double index, i.e. with each full rotation of the drive shaft, two indexes occur in the output.

²) Parallel drives with 12 stops are designed as a four step index, i.e. with each full rotation of the drive shaft, four indexes occur in the output.

³) The additional load occurring with chains and belts due to friction is not taken into consideration here and must be calculated separately.

Main Dimensions

Shaft distance [mm]	80
Weight without drive [kg]	16
Switching angle [°]	see Load Table
(other switching angles upon request)	
Number of stops	1,2,3,4,5,6,8,10,12
(other numbers of stops upon request)	
Rotating direction	right, left, oscillating
Mounting position	ANY

Capacities

Max. Output torque	See Load Table
Input Shaft	
Load rating dynamic [kN]	13.8
Load rating static [kN]	8.3
Output Shaft	
Load rating dynamic [kN]	13.8
Load rating static [kN]	8.3

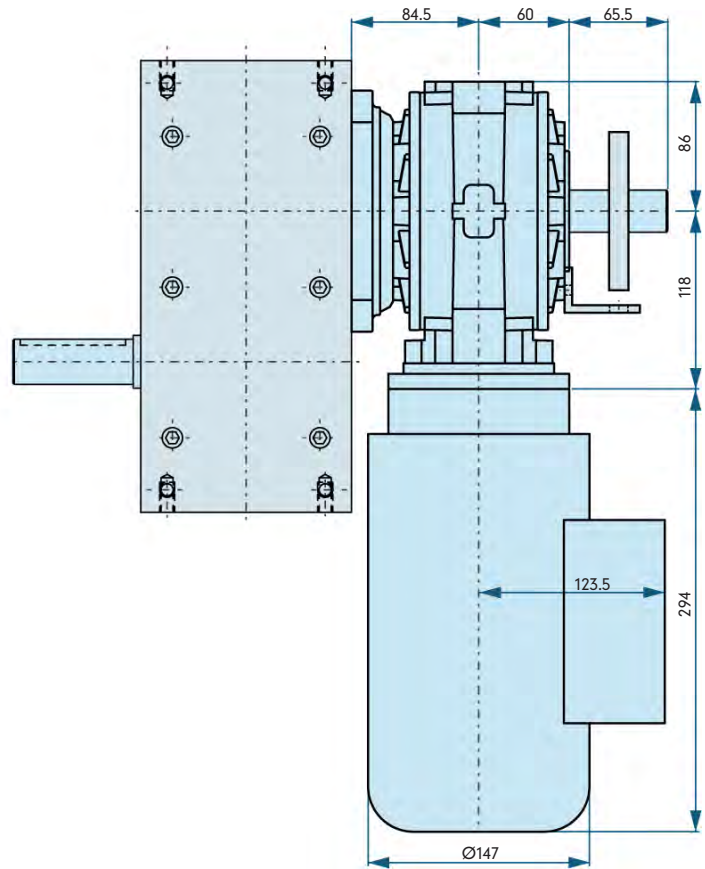
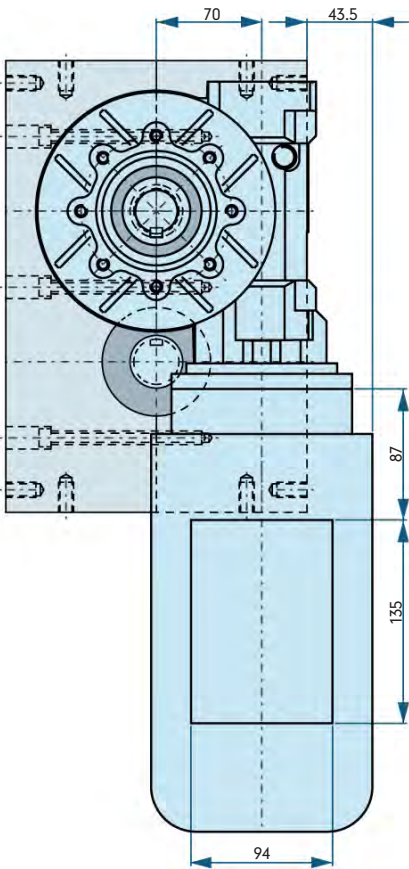
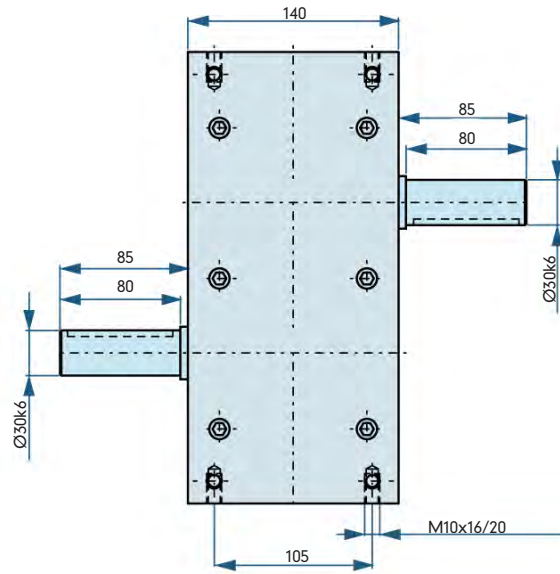
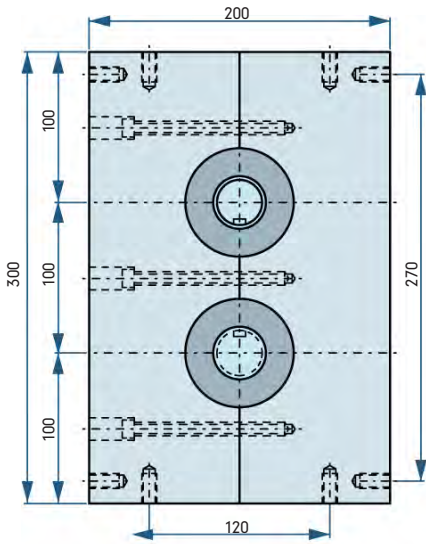

TP100 Dimensions

The measurements shown here illustrate the standard unit. We will gladly customize the housing and or shaft(s) to suit your needs. The drive shaft as well as the output shaft are available as double sided shafts with and without keyways. If you would like to add additional holes into the housing yourself, please contact us for possible drilling depths.

A = Drive Shaft

B = Output Shaft



The dimensions for the gearmotor may change based on the gearmotor size and options required for the application.

TP100 Load Table

Angle on Output Shaft [°]	Number of Stops n	Index Angle [°]	Acceleration Form MS	Indexer Torque M_{AB} [Nm]			Moment of Inertia J [kgm ²]			Mechanical Index Time t_s [S]		
				n=50	n=100	n=200	n=50	n=100	n=200	n=50	n=100	n=200
360°	1	330	MS30	211	171	135	4.1	0.8	0.2	1.1	0.55	0.28
		300	MS50	203	167	129	4	0.8	0.2	1	0.5	0.25
180°	2	270	MS0	290	259	225	9.3	2.1	0.5	0.9	0.45	0.23
		210	MS30	278	245	216	6.3	1.4	0.3	0.7	0.35	0.18
		150	MS50	248	199	151	2	0.4	0.1	0.5	0.25	0.13
120°	3	270	MS0	353	312	272	19.7	4.4	1	0.9	0.45	0.23
		210	MS30	342	305	264	10	2.2	0.5	0.7	0.35	0.18
		150	MS30	336	299	255	5	1.1	0.2	0.5	0.25	0.13
		120	MS30	332	294	250	3.2	0.7	0.1	0.4	0.2	0.1
90°	4	270	MS0	333	291	239	24.9	5.4	1.1	0.9	0.45	0.23
		210	MS0	322	284	233	14.6	3.2	0.7	0.7	0.35	0.18
		150	MS30	311	273	221	6.2	1.4	0.3	0.5	0.25	0.13
		90	MS30	285	263	216	2	0.5	0.1	0.3	0.15	0.08
72°	5	270	MS0	333	291	239	31.1	6.8	1.4	0.9	0.45	0.23
		210	MS0	322	284	233	18.2	4	0.8	0.7	0.35	0.18
		150	MS30	311	273	221	7.7	1.7	0.3	0.5	0.25	0.13
		90	MS30	285	263	216	2.6	0.6	0.1	0.3	0.15	0.08
60°	6 ¹	270	MS0	382	343	291	42.8	9.6	2	0.9	0.45	0.23
		240	MS0	368	331	279	32.6	7.3	1.5	0.8	0.4	0.2
		180	MS30	298	254	197	12.8	2.7	0.5	0.6	0.3	0.15
		120	MS30	275	234	176	5.2	1.1	0.2	0.4	0.2	0.1
45°	8 ¹	270	MS0	382	343	291	57	12.8	2.7	0.9	0.45	0.23
		240	MS0	368	331	279	43.4	9.8	2.1	0.8	0.4	0.2
		180	MS30	298	254	197	7	1.5	0.3	0.6	0.3	0.15
		120	MS30	275	234	176	7	1.5	0.3	0.4	0.2	0.1
36°	10 ¹	270	MS0	382	343	291	71.3	16	3.4	0.9	0.45	0.23
		240	MS0	368	331	279	54.3	12.2	2.6	0.8	0.4	0.2
		180	MS30	298	254	197	21.3	4.5	0.9	0.6	0.3	0.15
		120	MS30	275	234	176	8.7	1.9	0.3	0.4	0.2	0.1
30°	12 ²	240	MS0	264	215	166	46.7	9.5	1.8	0.8	0.4	0.2

¹) Parallel drives with stop numbers 6, 8 and 10 are designed as a double index, i.e. with each full rotation of the drive shaft, two indexes occur in the output.

²) Parallel drives with 12 stops are designed as a four step index, i.e. with each full rotation of the drive shaft, four indexes occur in the output.

³) The additional load occurring with chains and belts due to friction is not taken into consideration here and must be calculated separately.

Main Dimensions

Shaft distance [mm]	100
Weight without drive [kg]	25
Switching angle [°]	see Load Table
(other switching angles upon request)	
Number of stops	1,2,3,4,5,6,8,10,12
(other numbers of stops upon request)	
Rotating direction	right, left, oscillating
Mounting position	ANY

Capacities

Max. Output torque	See Load Table
Input Shaft	
Load rating dynamic [kN]	40
Load rating static [kN]	28
Output Shaft	
Load rating dynamic [kN]	40
Load rating static [kN]	28

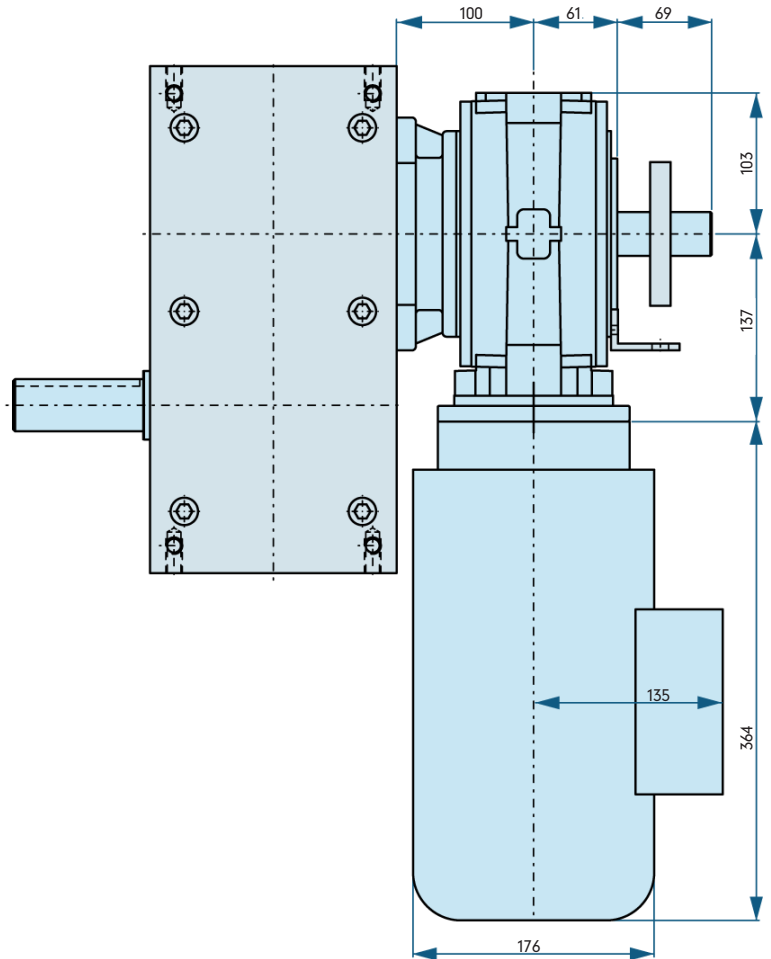
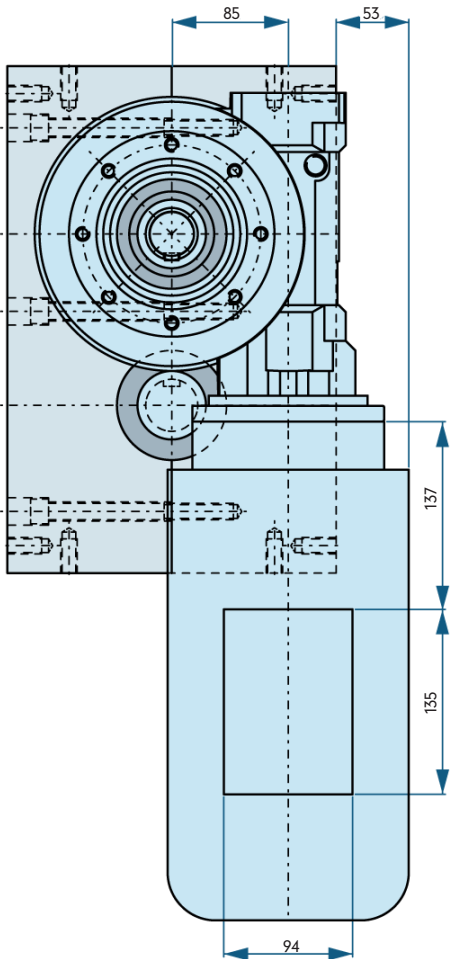
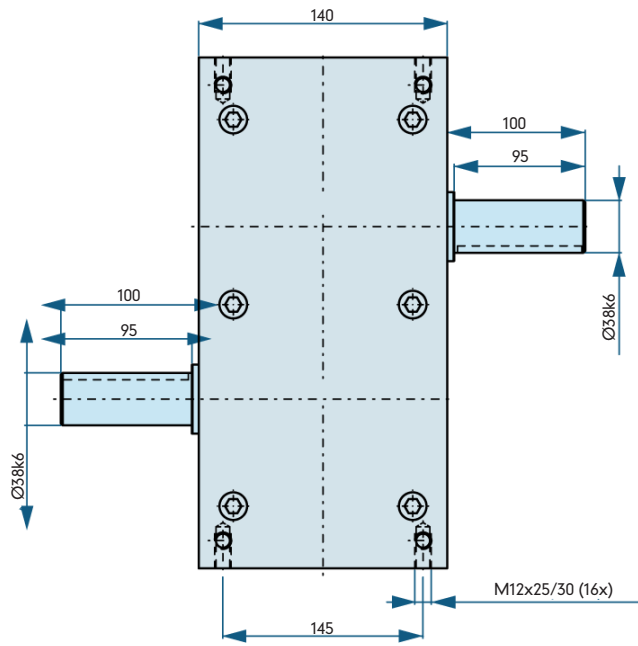
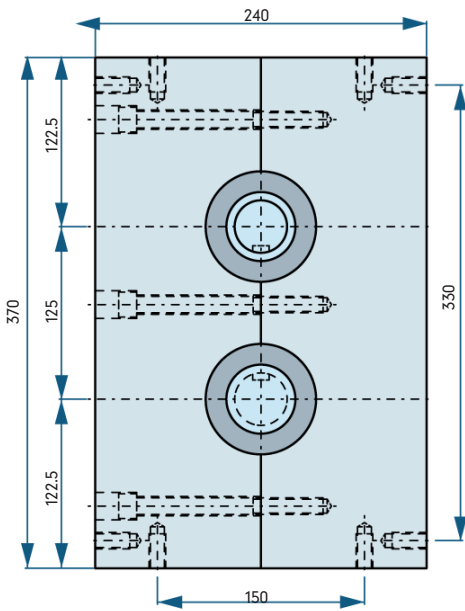

TP125 Dimensions

The measurements shown here illustrate the standard unit. We will gladly customize the housing and or shaft(s) to suit your needs. The drive shaft as well as the output shaft are available as double sided shafts with and without keyways. If you would like to add additional holes into the housing yourself, please contact us for possible drilling depths.

A = Drive Shaft

B = Output Shaft



The dimensions for the gearmotor may change based on the gearmotor size and options required for the application.

TP125 Load Table

Angle on Output Shaft [°]	Number of Stops n	Index Angle [°]	Acceleration Form MS	Indexer Torque M_{AB} [Nm]			Moment of Inertia J [kgm ²]			Mechanical Index Time t_s [S]		
				n=50	n=100	n=200	n=50	n=100	n=200	n=50	n=100	n=200
360°	1	330	MS30	349	282	221	6.7	1.4	0.3	1.1	0.55	0.28
		300	MS50	340	270	204	6.8	1.3	0.3	1	0.5	0.25
180°	2	270	MS0	436	360	294	14.1	2.9	0.6	0.9	0.45	0.23
		210	MS30	362	275	207	8.2	1.6	0.3	0.7	0.35	0.18
		150	MS50	301	222	160	2.4	0.4	0.1	0.5	0.25	0.13
120°	3	270	MS0	538	447	365	30.1	6.3	1.3	0.9	0.45	0.23
		210	MS30	505	424	350	14.8	3.1	0.6	0.7	0.35	0.18
		150	MS30	403	321	233	6	1.2	0.2	0.5	0.25	0.13
		120	MS30	379	277	204	3.6	0.7	0.1	0.4	0.2	0.1
90°	4	270	MS0	525	442	350	39.2	8.3	1.6	0.9	0.45	0.23
		210	MS0	487	401	316	22	4.5	0.9	0.7	0.35	0.18
		150	MS30	467	379	286	9.3	1.9	0.4	0.5	0.25	0.13
		90	MS30	428	336	256	3.1	0.6	0.1	0.3	0.15	0.08
72°	5	270	MS0	525	442	350	49	10.3	2	0.9	0.45	0.23
		210	MS0	487	401	316	27.5	5.7	1.1	0.7	0.35	0.18
		150	MS30	467	379	256	3.8	0.8	0.1	0.5	0.25	0.13
		90	MS30	428	336	256	3.8	0.8	0.1	0.3	0.15	0.08
60°	6 ¹	270	MS0	598	522	430	66.9	14.6	3	0.9	0.45	0.23
		240	MS0	560	469	379	49.5	10.4	2.1	0.8	0.4	0.2
		180	MS30	433	358	272	18.6	3.8	0.7	0.6	0.3	0.15
		120	MS30	384	311	232	7.3	1.5	0.3	0.4	0.2	0.1
45°	8 ¹	270	MS0	598	522	430	89.2	19.5	4	0.9	0.45	0.23
		240	MS0	560	469	379	66	13.8	2.8	0.8	0.4	0.2
		180	MS30	433	358	272	24.8	5.1	1	0.6	0.3	0.15
		120	MS30	384	311	232	9.8	2	0.4	0.4	0.2	0.1
36°	10 ¹	270	MS0	598	522	430	111.5	24.3	5	0.9	0.45	0.23
		240	MS0	560	469	379	82.5	17.3	3.5	0.8	0.4	0.2
		180	MS30	433	358	272	30.9	6.4	1.2	0.6	0.3	0.15
		120	MS30	384	311	232	12.2	2.5	0.5	0.4	0.2	0.1
30°	12 ²	240	MS0	350	282	224	61.9	12.5	2.5	0.8	0.4	0.2

¹) Parallel drives with stop numbers 6, 8 and 10 are designed as a double index, i.e. with each full rotation of the drive shaft, two indexes occur in the output.

²) Parallel drives with 12 stops are designed as a four step index, i.e. with each full rotation of the drive shaft, four indexes occur in the output.

³) The additional load occurring with chains and belts due to friction is not taken into consideration here and must be calculated separately.

Main Dimensions

Shaft distance [mm] 125
 Weight without drive [kg] 12
 Switching angle [°] see Load Table
 (other switching angles upon request)
 Number of stops 1,2,3,4,5,6,8,10,12
 (other numbers of stops upon request)
 Rotating direction right, left, oscillating
 Mounting position ANY

Capacities

Max. Output torque See Load Table
 Input Shaft
 Load rating dynamic [kN] 51
 Load rating static [kN] 39
 Output Shaft
 Load rating dynamic [kN] 51
 Load rating static [kN] 39

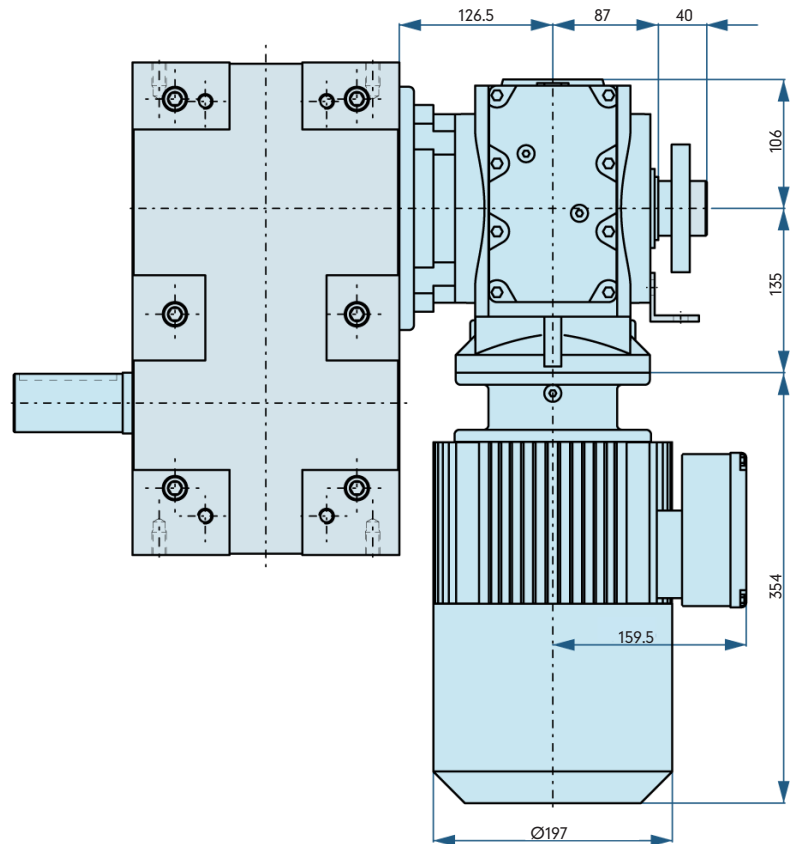
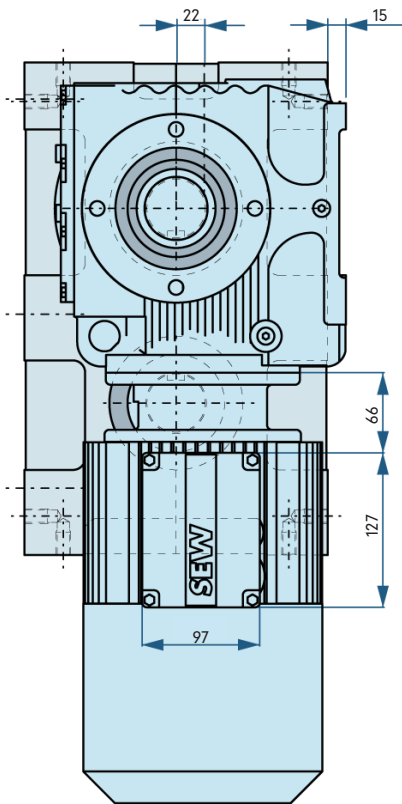
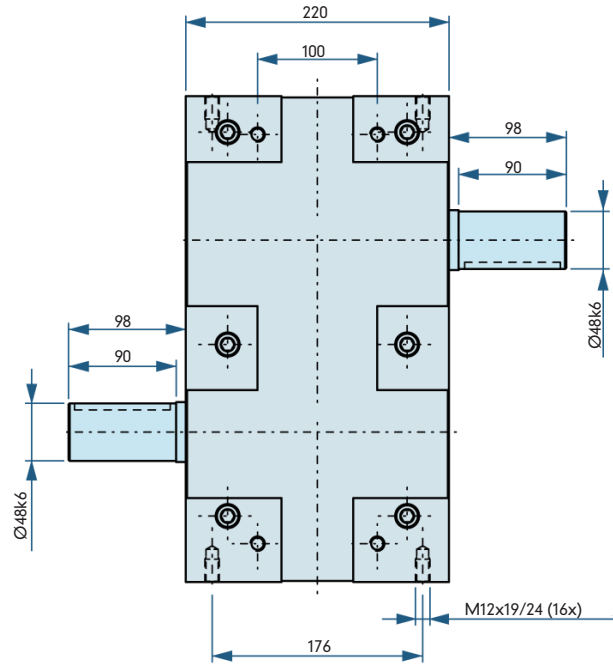
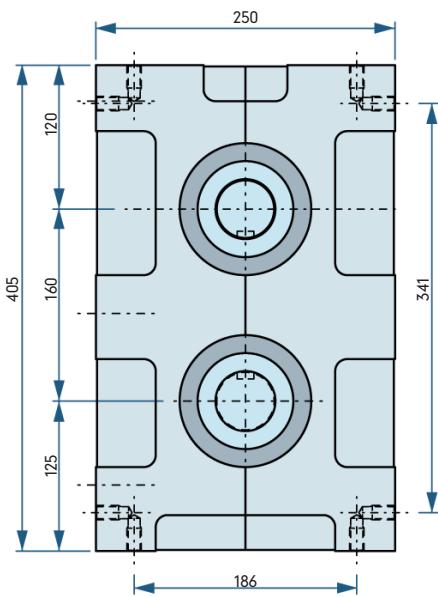

TP160 Dimensions

The measurements shown here illustrate the standard unit. We will gladly customize the housing and or shaft(s) to suit your needs. The drive shaft as well as the output shaft are available as double sided shafts with and without keyways. If you would like to add additional holes into the housing yourself, please contact us for possible drilling depths.

A = Drive Shaft

B = Output Shaft



The dimensions for the gearmotor may change based on the gearmotor size and options required for the application.

TP160 Load Table

Angle on Output Shaft [°]	Number of Stops n	Index Angle [°]	Acceleration Form MS	Indexer Torque M_{AB} [Nm]			Moment of Inertia J [kgm ²]			Mechanical Index Time t_s [S]		
				n=50	n=100	n=200	n=50	n=100	n=200	n=50	n=100	n=200
360°	1	330	MS30	894	739	598	17.2	3.6	0.7	1.1	0.55	0.28
		300	MS50	865	714	564	17.2	3.5	0.7	1	0.5	0.25
180°	2	270	MS0	904	816	661	29.1	6.6	1.3	0.9	0.45	0.23
		210	MS30	782	758	612	17.7	4.3	0.9	0.7	0.35	0.18
		150	MS50	768	719	583	6.1	1.4	0.3	0.5	0.25	0.13
120°	3	270	MS0	923	894	661	51.7	12.5	2.3	0.9	0.45	0.23
		210	MS30	816	787	573	23.9	5.8	1	0.7	0.35	0.18
		150	MS30	797	768	554	11.9	2.9	0.5	0.5	0.25	0.13
		120	MS30	782	748	525	7.5	1.8	0.3	0.4	0.2	0.1
90°	4	270	MS0	923	894	661	68.9	16.7	3.1	0.9	0.45	0.23
		210	MS0	816	787	573	36.9	8.9	1.6	0.7	0.35	0.18
		150	MS30	797	768	554	15.8	3.8	0.7	0.5	0.25	0.13
		90	MS30	782	748	525	5.6	1.3	0.2	0.3	0.15	0.08
72°	5	270	MS0	923	894	661	86.1	20.9	3.9	0.9	0.45	0.23
		210	MS0	816	787	573	46.1	11.1	2	0.7	0.35	0.18
		150	MS30	797	768	554	19.8	4.8	0.9	0.5	0.25	0.13
		90	MS30	782	748	525	7	1.7	0.3	0.3	0.15	0.08
60°	6 ¹	270	MS0	904	894	865	101.2	25	6.1	0.9	0.45	0.23
		240	MS0	885	875	846	78.2	19.3	4.7	0.8	0.4	0.2
		180	MS30	865	855	826	37.1	9.2	2.2	0.6	0.3	0.15
		120	MS30	836	816	797	15.9	3.9	1	0.4	0.2	0.1
45°	8 ¹	270	MS0	768	748	729	114.6	27.9	6.8	0.9	0.45	0.23
		240	MS0	748	729	710	88.3	21.5	5.2	0.8	0.4	0.2
		180	MS30	739	719	690	42.3	10.3	2.5	0.6	0.3	0.15
		120	MS30	729	710	700	18.5	4.5	1.1	0.4	0.2	0.1
36°	10 ¹	270	MS0	768	748	729	143.3	34.9	8.5	0.9	0.45	0.23
		240	MS0	748	729	710	110.3	26.9	6.5	0.8	0.4	0.2
		180	MS30	739	719	690	52.9	12.9	3.1	0.6	0.3	0.15
		120	MS30	729	710	700	23.2	5.6	1.4	0.4	0.2	0.1
30°	12 ²	240	MS0	710	700	680	125.5	31	7.5	0.8	0.4	0.2

¹) Parallel drives with stop numbers 6, 8 and 10 are designed as a double index, i.e. with each full rotation of the drive shaft, two indexes occur in the output.

²) Parallel drives with 12 stops are designed as a four step index, i.e. with each full rotation of the drive shaft, four indexes occur in the output.

³) The additional load occurring with chains and belts due to friction is not taken into consideration here and must be calculated separately.

Main Dimensions

Shaft distance [mm]	160
Weight without drive [kg]	117
Switching angle [°]	see Load Table
(other switching angles upon request)	
Number of stops	1,2,3,4,5,6,8,10,12
(other numbers of stops upon request)	
Rotating direction	right, left, oscillating
Mounting position	ANY

Capacities

Max. Output torque	See Load Table
Input Shaft	
Load rating dynamic [kN]	51
Load rating static [kN]	39
Output Shaft	
Load rating dynamic [kN]	168
Load rating static [kN]	270